

Ralph Blumenhagen
Erik Plauschinn

LECTURE NOTES IN PHYSICS 779

Introduction to Conformal Field Theory

With Applications to String Theory



Springer

Lecture Notes in Physics

Founding Editors: W. Beiglböck, J. Ehlers, K. Hepp, H. Weidenmüller

Editorial Board

R. Beig, Vienna, Austria
W. Beiglböck, Heidelberg, Germany
W. Domcke, Garching, Germany
B.-G. Englert, Singapore
U. Frisch, Nice, France
F. Guinea, Madrid, Spain
P. Hänggi, Augsburg, Germany
W. Hillebrandt, Garching, Germany
R. L. Jaffe, Cambridge, MA, USA
W. Janke, Leipzig, Germany
H. v. Löhneysen, Karlsruhe, Germany
M. Mangano, Geneva, Switzerland
J.-M. Raimond, Paris, France
D. Sornette, Zurich, Switzerland
S. Theisen, Potsdam, Germany
D. Vollhardt, Augsburg, Germany
W. Weise, Garching, Germany
J. Zittartz, Köln, Germany

The Lecture Notes in Physics

The series Lecture Notes in Physics (LNP), founded in 1969, reports new developments in physics research and teaching – quickly and informally, but with a high quality and the explicit aim to summarize and communicate current knowledge in an accessible way. Books published in this series are conceived as bridging material between advanced graduate textbooks and the forefront of research and to serve three purposes:

- to be a compact and modern up-to-date source of reference on a well-defined topic
- to serve as an accessible introduction to the field to postgraduate students and nonspecialist researchers from related areas
- to be a source of advanced teaching material for specialized seminars, courses and schools

Both monographs and multi-author volumes will be considered for publication. Edited volumes should, however, consist of a very limited number of contributions only. Proceedings will not be considered for LNP.

Volumes published in LNP are disseminated both in print and in electronic formats, the electronic archive being available at springerlink.com. The series content is indexed, abstracted and referenced by many abstracting and information services, bibliographic networks, subscription agencies, library networks, and consortia.

Proposals should be sent to a member of the Editorial Board, or directly to the managing editor at Springer:

Christian Caron
Springer Heidelberg
Physics Editorial Department I
Tiergartenstrasse 17
69121 Heidelberg / Germany
christian.caron@springer.com

R. Blumenhagen
E. Plauschinn

Introduction to Conformal Field Theory

With Applications to String Theory

 Springer

Ralph Blumenhagen
Max-Planck-Institut für Physik
Werner-Heisenberg-Institut
Föhringer Ring 6
80805 München
Germany

Erik Plauschinn
Max-Planck-Institut für Physik
Werner-Heisenberg-Institut
Föhringer Ring 6
80805 München
Germany

Blumenhagen, R., Plauschinn, E., *Introduction to Conformal Field Theory: With Applications to String Theory*, Lect. Notes Phys. 779 (Springer, Berlin Heidelberg 2009), DOI 10.1007/978-3-642-00450-6

ISBN 978-3-642-00449-0

e-ISBN 978-3-642-00450-6

DOI 10.1007/978-3-642-00450-6

Springer Dordrecht Heidelberg London New York

Lecture Notes in Physics ISSN 0075-8450

e-ISSN 1616-6361

Library of Congress Control Number: 2009921991

© Springer-Verlag Berlin Heidelberg 2009

This work is subject to copyright. All rights are reserved, whether the whole or part of the material is concerned, specifically the rights of translation, reprinting, reuse of illustrations, recitation, broadcasting, reproduction on microfilm or in any other way, and storage in data banks. Duplication of this publication or parts thereof is permitted only under the provisions of the German Copyright Law of September 9, 1965, in its current version, and permission for use must always be obtained from Springer. Violations are liable to prosecution under the German Copyright Law.

The use of general descriptive names, registered names, trademarks, etc. in this publication does not imply, even in the absence of a specific statement, that such names are exempt from the relevant protective laws and regulations and therefore free for general use.

Cover design: Integra Software Service Pvt. Ltd.

Printed on acid-free paper

Springer is part of Springer Science+Business Media (www.springer.com)

Preface

These lecture notes are based on a graduate course given at the “Ludwig-Maximilians-Universität München” during the winter term 2007/2008 as part of the “Theoretical and Mathematical Physics” master programme[‡]. Although the main target group of this course were master students, we decided to prepare these notes for a more general audience including Ph.D. students and Postdocs.

These lecture notes are intended to give an introduction to conformal field theories in two dimensions with special emphasis on computational issues important for applications in string theory. We assume the reader to be familiar with Quantum Mechanics on the level of a graduate course and to have some basic knowledge of quantum field theory, even though the later is not a necessity. The notions of conformal field theory will be introduced in due course, however, string theory is not introduced in a self-contained manner. While familiarity with string theory is not a prerequisite for understanding these notes, for students intending to appreciate the presented techniques we highly recommend to study an introductory book on string theory in parallel.

München, Germany

Ralph Blumenhagen
Erik Plauschinn

[‡] <http://www.theorie.physik.uni-muenchen.de/TMP/>

Acknowledgements

Ralph Blumenhagen would like to dedicate these lecture notes to his Ph.D. supervisor Werner Nahm, from whom, during the years 1991–1994, he learned the distinctive approach to conformal field theory partly leaving its mark in these lecture notes. Moreover, he wants to thank his former colleagues Wolfgang Eholzer, Michael Flohr, Andreas Honecker, Ralf Hübel, Johannes Kellendonk, Albrecht Kliem, Andreas Recknagel, Michael Rösger, Michael Terhoeven, Raimund Varnhagen and Andreas Wißkirchen for the many valuable, still not forgotten discussions.

Furthermore, both authors are indebted to Nikolas Akerblom, Sebastian Moster and Maximilian Schmidt-Sommerfeld for many valuable comments and questions during the lecture as well as during the preparation of these notes. We would also like to thank Andrei Constantin, Daniel Härtl and Satoshi Nawata for helpful comments on the manuscript. Finally, we want to express our special gratitude to Dieter Lüst and Stefan Theisen for their support in pushing these lecture notes towards publication.

Contents

1 Introduction	1
2 Basics in Conformal Field Theory	5
2.1 The Conformal Group	5
2.1.1 Conformal Invariance	5
2.1.2 Conformal Group in $d \geq 3$	8
2.1.3 Conformal Group in $d = 2$	12
2.2 Primary Fields	17
2.3 The Energy–Momentum Tensor	19
2.4 Radial Quantisation	20
2.5 The Operator Product Expansion	23
2.6 Operator Algebra of Chiral Quasi-Primary Fields	29
2.6.1 Conformal Ward Identity	29
2.6.2 Two- and Three-Point Functions	30
2.6.3 General Form of the OPE for Chiral Quasi-Primary Fields	32
2.7 Normal Ordered Products	37
2.8 The CFT Hilbert Space	41
2.9 Simple Examples of CFTs	44
2.9.1 The Free Boson	44
2.9.2 The Free Fermion	56
2.9.3 The (b,c) Ghost Systems	67
2.10 Highest Weight Representations of the Virasoro Algebra	70
2.11 Correlation Functions and Fusion Rules	76
2.12 Non-Holomorphic OPE and Crossing Symmetry	81
2.13 Fusing and Braiding Matrices	84
Further Reading	86
3 Symmetries of Conformal Field Theories	87
3.1 Kač–Moody Algebras	87
3.2 The Sugawara Construction	88
3.3 Highest Weight Representations of $\widehat{\mathfrak{su}}(2)_k$	92
3.4 The $\widehat{\mathfrak{sp}}(N)_1$ Current Algebra	97
3.5 The Knizhnik–Zamolodchikov Equation	99

3.6	Coset Construction	102
3.7	\mathcal{W} Algebras	106
	Further Reading	111
4	Conformal Field Theory on the Torus	113
4.1	The Modular Group of the Torus and the Partition Function	114
4.2	Examples for Partition Functions	120
4.2.1	The Free Boson	120
4.2.2	The Free Boson on a Circle	122
4.2.3	The Free Boson on a Circle of Radius $R = \sqrt{2k}$	126
4.2.4	The Free Fermion	130
4.2.5	The Free Boson Orbifold	138
4.3	The Verlinde Formula	142
4.4	The $\widehat{\mathfrak{su}}(2)_k$ Partition Functions	146
4.5	Modular Invariants of $\text{Vir}_{c<1}$	149
4.6	The Parafermions	152
4.7	Simple Currents	156
4.8	Additional Topics	164
4.8.1	Asymptotic Growth of States in RCFTs	164
4.8.2	Dilogarithm Identities	166
	Further Reading	167
5	Supersymmetric Conformal Field Theory	169
5.1	$\mathcal{N} = 1$ Superconformal Models	169
5.2	$\mathcal{N} = 2$ Superconformal Models	175
5.3	Chiral Ring	181
5.4	Spectral Flow	184
5.5	Coset Construction for the $\mathcal{N} = 2$ Unitary Series	187
5.6	Gepner Models	190
5.7	Massless Modes of Gepner Models	201
	Further Reading	203
6	Boundary Conformal Field Theory	205
6.1	The Free Boson with Boundaries	206
6.1.1	Boundary Conditions	206
6.1.2	Partition Function	211
6.2	Boundary States for the Free Boson	213
6.2.1	Boundary Conditions	214
6.2.2	Tree-Level Amplitudes	220
6.3	Boundary States for RCFTs	225
6.4	CFTs on Non-Orientable Surfaces	229
6.5	Crosscap States for the Free Boson	239
6.6	Crosscap States for RCFTs	245
6.7	The Orientifold of the Bosonic String	248
	Further Reading	256

Concluding Remarks 257

General Books on CFT and String Theory 259

Index 261

Chapter 1

Introduction

These lecture notes are mainly concerned with the study of conformal quantum field theories in two dimensions. Over the last 20 years, the understanding and mathematical formulation of such theories has developed to a very mature state, and conformal field theory (CFT) has influenced both mathematics and physics. As such, it can be considered a prototype example for a constructive interplay between these two subjects.

Compared to ordinary quantum field theories in four dimensions, conformal field theories in two dimensions can be defined in a rather abstract way via operator algebras and their representation theory. In fact, there are many examples of CFTs where the usual description in terms of a Lagrangian action with resulting perturbative expansion is not even known. Instead, following a so-called *boot-strap* approach, one can define these theories without making reference to an action and sometimes one can even solve them exactly. Such a procedure is possible because the algebra of infinitesimal conformal transformations in two dimensions is very special: in contrast to its higher dimensional counterparts, it is infinite dimensional and therefore highly constraining.

The main feature of a conformal field theory is the invariance under conformal transformations. Roughly speaking, these are transformations leaving angles invariant and a particular example is the scaling $\vec{x} \mapsto a\vec{x}$ of a point \vec{x} by some constant a . A field theory exhibiting such a symmetry has no preferred scale and one can only expect a physical system to have this property, if there are no dimensionful scales involved.

At first sight, it seems hard to find examples for such systems. However, the field theory of a free boson encounters a conformal symmetry for the case of vanishing mass. And even for interacting theories it is known that at the fixed point of a renormalisation group flow, there are only long-range correlations. Therefore, the natural mass scale at this point, that is, the inverse of the correlation length, vanishes and a conformal field theory description might be available. Physical systems with a conformal symmetry are thus more common than one would have naively expected.

More concrete examples featuring a conformal symmetry are the following. For statistical models in two dimensions, the continuum description at a second-order

phase transition is given by a conformal field theory. The prime example is the so-called Ising model which is a two-dimensional model of a ferromagnet. It has been shown to be integrable and to have a critical temperature where a second-order phase transition occurs.

Another important instance featuring conformal symmetry is string theory, which is a candidate theory for the unification of all interactions including gravity. Here, the CFT arises as a two-dimensional field theory living on the world-volume of a string which moves in some background space–time. The dynamics of this string is governed by a so-called non-linear sigma model whose condition for conformal invariance, that is, the vanishing of the β -functional, gives the string equations of motion. The sigma model perturbation theory is governed by an expansion in ℓ_s/R , where ℓ_s is the natural string length and R a typical length scale of the background geometry. With the help of CFT techniques, one can solve this theory exactly to all orders in perturbation theory and one can sum all contributions of so-called world-sheet instantons. Therefore, conformal field theory is a very powerful tool for string theory, not only in the perturbative regime $\ell_s/R \ll 1$ but also at small length scales $R \sim \ell_s$ where genuine string effects become important and geometric intuition often fails.

These lecture notes are based on a 30×1.5 hours of graduate course for master students and thus provide only a first introduction into the broad field of conformal field theory. In particular, the main emphasis of this course was on applications of CFT techniques to string theory and so we will neither attempt to give an axiomatic approach to CFTs nor are we giving a complete survey of the many advances in this field. Instead, we are going to present some topics important for string theory which are usually not covered in the standard CFT literature. This includes super-conformal field theories (SCFTs), a very powerful class of exactly solvable string compactifications known as Gepner models, and boundary conformal field theory (BCFT), which in string theory appears for the description of so-called D-branes. A more detailed overview is the following:

- In Chap. 2 of these notes, we study the basic properties of conformal field theories including the discussion of the conformal group, primary fields, radial quantisation, the operator product expansion, the operator algebra of chiral quasi-primary fields and the representation theory of the Virasoro algebra. However, due to our personal selection of priorities, not all mathematical details are proven in a rigorous way. Instead, we put more emphasis on providing computational techniques which have been proven to be useful in string theory.
- In Chap. 3, we discuss in more detail symmetries of conformal field theories which are crucial for their solvability. In particular, we study infinite-dimensional generalisations of Lie algebras known as Kač–Moody algebras, and we see how they define concrete examples of CFTs. This involves a presentation of the Sugawara and coset constructions. Moreover, we also explain non-linear extensions of the Virasoro algebra, the so-called \mathcal{W} algebras.

- In Chap. 4, we move forward and study CFTs on the torus where new consistency conditions arise from the action of the modular group. We present some simple but important examples such as the free boson, the free fermion, orbifold CFTs and the parafermionic CFT. We also state the Verlinde formula and discuss the simple current construction which is important for string theory.
- In Chap. 5, we present the generalisations of our previous findings to Supersymmetric conformal field theories. In particular, $\mathcal{N} = 2$ SCFTs have important applications in string theory as they are the underlying structure for compactifications preserving supersymmetry in four space–time dimensions. We will discuss the spectral flow operator, the chiral ring and the so-called Gepner models which are exactly known backgrounds in string theory valid beyond the perturbative level.
- In Chap. 6, we finally discuss boundary conformal field theories which in string theory describe open strings ending on D-branes. We show that these BCFTs can be defined in an abstract two-dimensional way without referring to the space–time notion of D-branes, we discuss the computation of partition functions for BCFTs and we introduce CFTs defined on non-orientable surfaces. With all this structure available, as the last result of this lecture, we derive the condition that the orientifold of the bosonic string has gauge group $SO(8192)$ in 26 dimensions.

Chapter 2

Basics in Conformal Field Theory

The approach for studying conformal field theories is somewhat different from the usual approach for quantum field theories. Because, instead of starting with a classical action for the fields and quantising them via the canonical quantisation or the path integral method, one employs the symmetries of the theory. In the spirit of the so-called boot-strap approach, for CFTs one defines and for certain cases even solves the theory just by exploiting the consequences of the symmetries. Such a procedure is possible in two dimensions because the algebra of infinitesimal conformal transformations in this case is very special: it is infinite dimensional.

In this chapter, we will introduce the basic notions of two-dimensional conformal field theory from a rather abstract point of view. However, in Sect. 2.9, we will study in detail three simple examples important for string theory which are given by a Lagrangian action.

2.1 The Conformal Group

We start by introducing conformal transformations and determining the condition for conformal invariance. Next, we are going to consider flat space in $d \geq 3$ dimensions and identify the conformal group. Finally, we study in detail the case of Euclidean two-dimensional flat space $\mathbb{R}^{2,0}$ and determine the conformal group and the algebra of infinitesimal conformal transformations. We also comment on two-dimensional Minkowski space $\mathbb{R}^{1,1}$ in the end.

2.1.1 Conformal Invariance

Conformal Transformations

Let us consider a flat space in d dimensions and transformations thereof which locally preserve the angle between any two lines. Such transformations are illustrated in Fig. 2.1 and are called *conformal transformations*.

In more mathematical terms, a conformal transformation is defined as follows. Let us consider differentiable maps $\varphi : U \rightarrow V$, where $U \subset M$ and $V \subset M'$ are

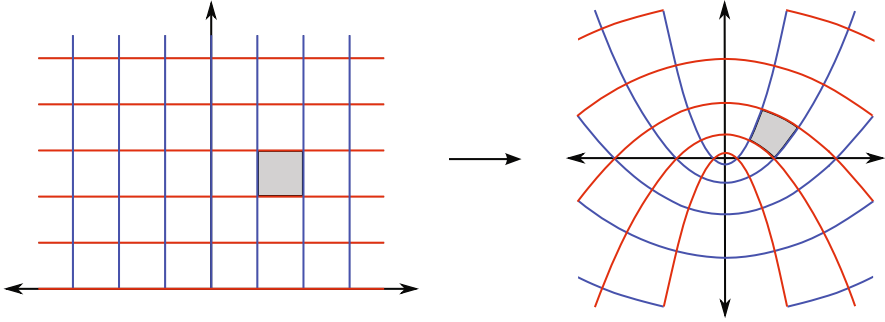

Fig. 2.1 Conformal transformation in two dimensions

open subsets. A map φ is called a conformal transformation, if the metric tensor satisfies $\varphi^* g' = \Lambda g$. Denoting $x' = \varphi(x)$ with $x \in U$, we can express this condition in the following way:

$$g'_{\rho\sigma}(x') \frac{\partial x'^{\rho}}{\partial x^{\mu}} \frac{\partial x'^{\sigma}}{\partial x^{\nu}} = \Lambda(x) g_{\mu\nu}(x),$$

where the positive function $\Lambda(x)$ is called the scale factor and Einstein's sum convention is understood. However, in these lecture notes, we focus on $M' = M$ which implies $g' = g$, and we will always consider flat spaces with a constant metric of the form $\eta_{\mu\nu} = \text{diag}(-1, \dots, +1, \dots)$. In this case, the condition for a conformal transformation can be written as

$$\boxed{\eta_{\rho\sigma} \frac{\partial x'^{\rho}}{\partial x^{\mu}} \frac{\partial x'^{\sigma}}{\partial x^{\nu}} = \Lambda(x) \eta_{\mu\nu}}. \quad (2.1)$$

Note furthermore, for flat spaces the scale factor $\Lambda(x) = 1$ corresponds to the Poincaré group consisting of translations and rotations, respectively Lorentz transformations.

Conditions for Conformal Invariance

Let us next study infinitesimal coordinate transformations which up to first order in a small parameter $\epsilon(x) \ll 1$ read

$$x'^{\rho} = x^{\rho} + \epsilon^{\rho}(x) + \mathcal{O}(\epsilon^2). \quad (2.2)$$

Noting that $\epsilon_{\mu} = \eta_{\mu\nu} \epsilon^{\nu}$ as well as that $\eta_{\mu\nu}$ is constant, the left-hand side of Eq. (2.1) for such a transformation is determined to be of the following form:

$$\begin{aligned}
\eta_{\rho\sigma} \frac{\partial x'^{\rho}}{\partial x^{\mu}} \frac{\partial x'^{\sigma}}{\partial x^{\nu}} &= \eta_{\rho\sigma} \left(\delta_{\mu}^{\rho} + \frac{\partial \epsilon^{\rho}}{\partial x^{\mu}} + \mathcal{O}(\epsilon^2) \right) \left(\delta_{\nu}^{\sigma} + \frac{\partial \epsilon^{\sigma}}{\partial x^{\nu}} + \mathcal{O}(\epsilon^2) \right) \\
&= \eta_{\mu\nu} + \eta_{\mu\sigma} \frac{\partial \epsilon^{\sigma}}{\partial x^{\nu}} + \eta_{\rho\nu} \frac{\partial \epsilon^{\rho}}{\partial x^{\mu}} + \mathcal{O}(\epsilon^2) \\
&= \eta_{\mu\nu} + \left(\frac{\partial \epsilon_{\mu}}{\partial x^{\nu}} + \frac{\partial \epsilon_{\nu}}{\partial x^{\mu}} \right) + \mathcal{O}(\epsilon^2) .
\end{aligned}$$

The question we want to ask now is, under what conditions is the transformation (2.2) conformal, i.e. when is Eq. (2.1) satisfied? Introducing the short-hand notation $\frac{\partial}{\partial x^{\mu}} = \partial_{\mu}$, from the last formula we see that, up to first order in ϵ , we have to demand that

$$\partial_{\mu} \epsilon_{\nu} + \partial_{\nu} \epsilon_{\mu} = K(x) \eta_{\mu\nu} ,$$

where $K(x)$ is some function. This function can be determined by tracing the equation above with $\eta^{\mu\nu}$

$$\begin{aligned}
\eta^{\mu\nu} \left(\partial_{\mu} \epsilon_{\nu} + \partial_{\nu} \epsilon_{\mu} \right) &= K(x) \eta^{\mu\nu} \eta_{\mu\nu} \\
2 \partial^{\mu} \epsilon_{\mu} &= K(x) d .
\end{aligned}$$

Using this expression and solving for $K(x)$, we find the following restriction on the transformation (2.2) to be conformal:

$$\boxed{\partial_{\mu} \epsilon_{\nu} + \partial_{\nu} \epsilon_{\mu} = \frac{2}{d} (\partial \cdot \epsilon) \eta_{\mu\nu}} , \quad (2.3)$$

where we employed the notation $\partial^{\mu} \epsilon_{\mu} = \partial \cdot \epsilon$. Finally, the scale factor can be read off as $\Lambda(x) = 1 + \frac{2}{d} (\partial \cdot \epsilon) + \mathcal{O}(\epsilon^2)$.

Some Useful Relations

Let us now derive two useful equations for later purpose. First, we modify Eq. (2.3) by taking the derivative ∂^{ν} and summing over ν . We then obtain

$$\begin{aligned}
\partial^{\nu} \left(\partial_{\mu} \epsilon_{\nu} + \partial_{\nu} \epsilon_{\mu} \right) &= \frac{2}{d} \partial^{\nu} (\partial \cdot \epsilon) \eta_{\mu\nu} \\
\partial_{\mu} (\partial \cdot \epsilon) + \square \epsilon_{\mu} &= \frac{2}{d} \partial_{\mu} (\partial \cdot \epsilon)
\end{aligned}$$

with $\square = \partial^{\mu} \partial_{\mu}$. Furthermore, we take the derivative ∂_{ν} to find

$$\partial_{\mu} \partial_{\nu} (\partial \cdot \epsilon) + \square \partial_{\nu} \epsilon_{\mu} = \frac{2}{d} \partial_{\mu} \partial_{\nu} (\partial \cdot \epsilon) . \quad (2.4)$$

After interchanging $\mu \leftrightarrow \nu$, adding the resulting expression to Eq. (2.4) and using Eq. (2.3) we get

$$\begin{aligned} 2 \partial_\mu \partial_\nu (\partial \cdot \epsilon) + \square \left(\frac{2}{d} (\partial \cdot \epsilon) \eta_{\mu\nu} \right) &= \frac{4}{d} \partial_\mu \partial_\nu (\partial \cdot \epsilon) , \\ \Rightarrow \left(\eta_{\mu\nu} \square + (d-2) \partial_\mu \partial_\nu \right) (\partial \cdot \epsilon) &= 0 . \end{aligned}$$

Finally, contracting this equation with $\eta^{\mu\nu}$ gives

$$\boxed{(d-1) \square (\partial \cdot \epsilon) = 0} . \quad (2.5)$$

The second expression we want to use later is obtained by taking derivatives ∂_ρ of Eq. (2.3) and permuting indices

$$\begin{aligned} \partial_\rho \partial_\mu \epsilon_\nu + \partial_\rho \partial_\nu \epsilon_\mu &= \frac{2}{d} \eta_{\mu\nu} \partial_\rho (\partial \cdot \epsilon) , \\ \partial_\nu \partial_\rho \epsilon_\mu + \partial_\mu \partial_\rho \epsilon_\nu &= \frac{2}{d} \eta_{\rho\mu} \partial_\nu (\partial \cdot \epsilon) , \\ \partial_\mu \partial_\nu \epsilon_\rho + \partial_\nu \partial_\mu \epsilon_\rho &= \frac{2}{d} \eta_{\nu\rho} \partial_\mu (\partial \cdot \epsilon) . \end{aligned}$$

Subtracting then the first line from the sum of the last two leads to

$$2 \partial_\mu \partial_\nu \epsilon_\rho = \frac{2}{d} (-\eta_{\mu\nu} \partial_\rho + \eta_{\rho\mu} \partial_\nu + \eta_{\nu\rho} \partial_\mu) (\partial \cdot \epsilon) . \quad (2.6)$$

2.1.2 Conformal Group in $d \geq 3$

After having obtained the condition for an infinitesimal transformations to be conformal, let us now determine the conformal group in the case of dimension $d \geq 3$.

Conformal Transformations and Generators

We note that Eq. (2.5) implies that $(\partial \cdot \epsilon)$ is at most linear in x^μ , i.e. $(\partial \cdot \epsilon) = A + B_\mu x^\mu$ with A and B_μ constant. Then it follows that ϵ_μ is at most quadratic in x^ν and so we can make the ansatz:

$$\epsilon_\mu = a_\mu + b_{\mu\nu} x^\nu + c_{\mu\nu\rho} x^\nu x^\rho , \quad (2.7)$$

where $a_\mu, b_{\mu\nu}, c_{\mu\nu\rho} \ll 1$ are constants and the latter is symmetric in the last two indices, i.e. $c_{\mu\nu\rho} = c_{\mu\rho\nu}$. We now study the various terms in Eq. (2.7) separately because the constraints for conformal invariance have to be independent of the position x^μ .

- The constant term a_μ in Eq. (2.7) is not constrained by Eq. (2.3). It describes infinitesimal translations $x'^\mu = x^\mu + a^\mu$, for which the generator is the momentum operator $P_\mu = -i\partial_\mu$.
- In order to study the term of Eq. (2.7) which is linear in x , we insert (2.7) into the condition (2.3) to find

$$b_{\nu\mu} + b_{\mu\nu} = \frac{2}{d} (\eta^{\rho\sigma} b_{\sigma\rho}) \eta_{\mu\nu} .$$

From this expression, we see that $b_{\mu\nu}$ can be split into a symmetric and an anti-symmetric part

$$b_{\mu\nu} = \alpha \eta_{\mu\nu} + m_{\mu\nu} ,$$

where $m_{\mu\nu} = -m_{\nu\mu}$. The symmetric term $\alpha \eta_{\mu\nu}$ describes infinitesimal scale transformations $x'^\mu = (1 + \alpha) x^\mu$ with generator $D = -ix^\mu \partial_\mu$. The anti-symmetric part $m_{\mu\nu}$ corresponds to infinitesimal rotations $x'^\mu = (\delta_\nu^\mu + m^\mu{}_\nu) x^\nu$ with generator being the angular momentum operator $L_{\mu\nu} = i(x_\mu \partial_\nu - x_\nu \partial_\mu)$.

- The term of Eq. (2.7) at quadratic order in x can be studied by inserting Eq. (2.7) into expression (2.6). We then calculate

$$\partial \cdot \epsilon = b^\mu{}_\mu x^\rho + 2 c^\mu{}_{\rho\rho} x^\rho \quad \Rightarrow \quad \partial_\nu (\partial \cdot \epsilon) = 2 c^\mu{}_{\mu\nu} ,$$

from which we find that

$$c_{\mu\nu\rho} = \eta_{\mu\rho} b_\nu + \eta_{\mu\nu} b_\rho - \eta_{\nu\rho} b_\mu \quad \text{with} \quad b_\mu = \frac{1}{d} c^\rho{}_{\rho\mu} .$$

The resulting transformations are called *Special Conformal Transformations* (SCT) and have the following infinitesimal form:

$$x'^\mu = x^\mu + 2(x \cdot b)x^\mu - (x \cdot x) b^\mu . \quad (2.8)$$

The corresponding generator is written as $K_\mu = -i(2x_\mu x^\nu \partial_\nu - (x \cdot x) \partial_\mu)$.

We have now identified the infinitesimal conformal transformations. However, in order to determine the conformal group, we will need the finite conformal transformations which are summarised in Table 2.1 together with the corresponding generators.

Focus on Special Conformal Transformations

For the finite Special Conformal Transformation shown in Table 2.1, one can check that expression (2.8) is its infinitesimal version by expanding the denominator for small b^μ . Furthermore, the scale factor for SCTs is computed as

$$\Lambda(x) = \left(1 - 2(b \cdot x) + (b \cdot b)(x \cdot x) \right)^2 .$$

Table 2.1 Finite conformal transformations and corresponding generators

Transformations		Generators
translation	$x'^{\mu} = x^{\mu} + a^{\mu}$	$P_{\mu} = -i \partial_{\mu}$
dilation	$x'^{\mu} = \alpha x^{\mu}$	$D = -i x^{\mu} \partial_{\mu}$
rotation	$x'^{\mu} = M^{\mu}_{\nu} x^{\nu}$	$L_{\mu\nu} = i (x_{\mu} \partial_{\nu} - x_{\nu} \partial_{\mu})$
SCT	$x'^{\mu} = \frac{x^{\mu} - (x \cdot x) b^{\mu}}{1 - 2(b \cdot x) + (b \cdot b)(x \cdot x)}$	$K_{\mu} = -i (2x_{\mu} x^{\nu} \partial_{\nu} - (x \cdot x) \partial_{\mu})$

Let us also note that for finite Special Conformal Transformations, we can re-write the expression in Table 2.1 as follows:

$$\frac{x'^{\mu}}{x' \cdot x'} = \frac{x^{\mu}}{x \cdot x} - b^{\mu} .$$

From this relation, we see that the SCTs can be understood as an inversion of x^{μ} , followed by a translation b^{μ} , and followed again by an inversion. An illustration in two dimensions is shown in Fig. 2.2.

Finally, we observe that the finite Special Conformal Transformations given in Table 2.1 are not globally defined. In particular, for a given non-zero vector b^{μ} , there is a point $x^{\mu} = \frac{1}{b \cdot b} b^{\mu}$ such that

$$1 - 2(b \cdot x) + (b \cdot b)(x \cdot x) = 0 .$$

Taking into account also the numerator, one finds that x^{μ} is mapped to infinity which does not belong to $\mathbb{R}^{d,0}$ or $\mathbb{R}^{d-1,1}$. Therefore, in order to define the finite conformal transformations globally, one considers the so-called conformal compactifications of $\mathbb{R}^{d,0}$ or $\mathbb{R}^{d-1,1}$, where additional points are included such that the conformal

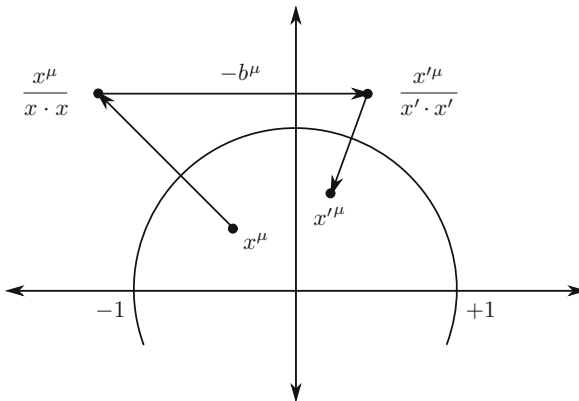

Fig. 2.2 Illustration of a finite Special Conformal Transformation

transformations are globally defined. We will not go into further detail here, but come back to this issue in Sect. 2.1.3.

The Conformal Group and Algebra

Before we identify the conformal group and the conformal algebra for the case of dimensions $d \geq 3$, let us first define these objects and point out a subtle difference.

Definition 1. *The conformal group is the group consisting of globally defined, invertible and finite conformal transformations (or more concretely, conformal diffeomorphisms).*

Definition 2. *The conformal algebra is the Lie algebra corresponding to the conformal group.*

Note that the algebra consisting of generators of infinitesimal conformal transformations contains the conformal algebra as a subalgebra, but it is larger in general. We will encounter an example of this fact in the case of two Euclidean dimensions.

Determining the Conformal Group

Let us finally determine the conformal group for dimensions $d \geq 3$. Since the group is closely related to its algebra, we will concentrate on the later. With the help of Table 2.1, we can fix the dimension of the algebra by counting the total number of generators. Keeping in mind that $L_{\mu\nu}$ is anti-symmetric, we find $N = d + 1 + \frac{d(d-1)}{2} + d = \frac{(d+2)(d+1)}{2}$. Guided by this result, we perform the definitions

$$\begin{aligned} J_{\mu,\nu} &= L_{\mu\nu}, & J_{-1,\mu} &= \frac{1}{2}(P_\mu - K_\mu), \\ J_{-1,0} &= D, & J_{0,\mu} &= \frac{1}{2}(P_\mu + K_\mu). \end{aligned}$$

One can then verify that $J_{m,n}$ with $m, n = -1, 0, 1, \dots, (d-1)$ satisfy the following commutation relations:

$$[J_{mn}, J_{rs}] = i(\eta_{ms}J_{nr} + \eta_{nr}J_{ms} - \eta_{mr}J_{ns} - \eta_{ns}J_{mr}). \quad (2.9)$$

For Euclidean d -dimensional space $\mathbb{R}^{d,0}$, the metric η_{mn} used above is $\eta_{mn} = \text{diag}(-1, 1, \dots, 1)$ and so we identify Eq. (2.9) as the commutation relations of the Lie algebra $\mathfrak{so}(d+1, 1)$. Similarly, in the case of $\mathbb{R}^{d-1,1}$, the metric is $\eta_{mn} = \text{diag}(-1, -1, 1, \dots, 1)$ for which Eq. (2.9) are the commutation relations of the Lie algebra $\mathfrak{so}(d, 2)$. These two examples are illustrations of the general result that

For the case of dimensions $d = p + q \geq 3$, the conformal group of $\mathbb{R}^{p,q}$ is $SO(p+1, q+1)$.

2.1.3 Conformal Group in $d = 2$

Let us now study the conformal group for the special case of two dimensions. We will work with an Euclidean metric in a flat space but address the case of Lorentzian signature in the end.

Conformal Transformations

The condition (2.3) for invariance under infinitesimal conformal transformations in two dimensions reads as follows:

$$\partial_0 \epsilon_0 = +\partial_1 \epsilon_1, \quad \partial_0 \epsilon_1 = -\partial_1 \epsilon_0, \quad (2.10)$$

which we recognise as the familiar Cauchy–Riemann equations appearing in complex analysis. A complex function whose real and imaginary parts satisfy Eq. (2.10) is a holomorphic function (in some open set). We then introduce complex variables in the following way:

$$\begin{aligned} z &= x^0 + ix^1, & \epsilon &= \epsilon^0 + i\epsilon^1, & \partial_z &= \frac{1}{2}(\partial_0 - i\partial_1), \\ \bar{z} &= x^0 - ix^1, & \bar{\epsilon} &= \epsilon^0 - i\epsilon^1, & \partial_{\bar{z}} &= \frac{1}{2}(\partial_0 + i\partial_1). \end{aligned}$$

Since $\epsilon(z)$ is holomorphic, so is $f(z) = z + \epsilon(z)$ from which we conclude that

A holomorphic function $f(z) = z + \epsilon(z)$ gives rise to an infinitesimal two-dimensional conformal transformation $z \mapsto f(z)$.

This implies that the metric tensor transforms under $z \mapsto f(z)$ as follows:

$$ds^2 = dz d\bar{z} \mapsto \frac{\partial f}{\partial z} \frac{\partial \bar{f}}{\partial \bar{z}} dz d\bar{z},$$

from which we infer the scale factor as $\left| \frac{\partial f}{\partial z} \right|^2$.

The Witt Algebra

As we have observed above, for an infinitesimal conformal transformation in two dimensions the function $\epsilon(z)$ has to be holomorphic in some open set. However, it is reasonable to assume that $\epsilon(z)$ in general is a meromorphic function having isolated singularities outside this open set. We therefore perform a Laurent expansion of $\epsilon(z)$ around say $z = 0$. A general infinitesimal conformal transformation can then be written as

$$z' = z + \epsilon(z) = z + \sum_{n \in \mathbb{Z}} \epsilon_n (-z^{n+1}),$$

$$\bar{z}' = \bar{z} + \bar{\epsilon}(\bar{z}) = \bar{z} + \sum_{n \in \mathbb{Z}} \bar{\epsilon}_n (-\bar{z}^{n+1}),$$

where the infinitesimal parameters ϵ_n and $\bar{\epsilon}_n$ are constant. The generators corresponding to a transformation for a particular n are

$$l_n = -z^{n+1} \partial_z \quad \text{and} \quad \bar{l}_n = -\bar{z}^{n+1} \partial_{\bar{z}}. \quad (2.11)$$

It is important to note that since $n \in \mathbb{Z}$, the number of independent infinitesimal conformal transformations is *infinite*. This observation is special to two dimensions and we will see that it has far-reaching consequences.

As a next step, let us compute the commutators of the generators (2.11) in order to determine the corresponding algebra. We calculate

$$\begin{aligned} [l_m, l_n] &= z^{m+1} \partial_z (z^{n+1} \partial_z) - z^{n+1} \partial_z (z^{m+1} \partial_z) \\ &= (n+1) z^{m+n+1} \partial_z - (m+1) z^{m+n+1} \partial_z \\ &= -(m-n) z^{m+n+1} \partial_z \\ &= (m-n) l_{m+n}, \end{aligned} \quad (2.12)$$

$$[\bar{l}_m, \bar{l}_n] = (m-n) \bar{l}_{m+n},$$

$$[l_m, \bar{l}_n] = 0.$$

The first commutation relations define one copy of the so-called *Witt algebra*, and because of the other two relations, there is a second copy which commutes with the first one. We can then summarise our findings as follows:

The algebra of infinitesimal conformal transformations in an Euclidean two-dimensional space is *infinite* dimensional.

Note that, since we can identify two independent copies of the Witt algebra generated by Eq. (2.11), it is customary to treat z and \bar{z} as independent variables which means that we are effectively considering \mathbb{C}^2 instead of \mathbb{C} . We will come back to this point in Sect. 2.2.

Global Conformal Transformations

Let us now focus on the copy of the Witt algebra generated by $\{l_n\}$ and observe that on the Euclidean plane $\mathbb{R}^2 \simeq \mathbb{C}$, the generators l_n are not everywhere defined. In particular, there is an ambiguity at $z = 0$ and it turns out to be necessary not to work

on \mathbb{C} but on the Riemann sphere $S^2 \simeq \mathbb{C} \cup \{\infty\}$ being the conformal compactification of \mathbb{R}^2 .

But even on the Riemann sphere, not all of the generators (2.11) are well defined. For $z = 0$, we find that

$$l_n = -z^{n+1} \partial_z, \quad \text{non-singular at } z = 0 \text{ only for } n \geq -1 .$$

The other ambiguous point is $z = \infty$ which is, however, part of the Riemann sphere S^2 . To investigate the behaviour of l_n there, let us perform the change of variable $z = -\frac{1}{w}$ and study $w \rightarrow 0$. We then observe that

$$l_n = -\left(-\frac{1}{w}\right)^{n-1} \partial_w, \quad \text{non-singular at } w = 0 \text{ only for } n \leq +1 ,$$

where we employed that $\partial_z = (-w)^2 \partial_w$. We therefore arrive at the conclusion that

Globally defined conformal transformations on the Riemann sphere $S^2 = \mathbb{C} \cup \infty$ are generated by $\{l_{-1}, l_0, l_{+1}\}$.

The Conformal Group

After having determined the operators generating global conformal transformations, we will now determine the conformal group.

- As it is clear from its definition, the operator l_{-1} generates translations $z \mapsto z + b$.
- For the operator l_0 , let us recall that $l_0 = -z \partial_z$. Therefore, l_0 generates transformations $z \mapsto a z$ with $a \in \mathbb{C}$. In order to get a geometric intuition of such transformations, we perform the change of variables $z = r e^{i\phi}$ to find

$$l_0 = -\frac{1}{2} r \partial_r + \frac{i}{2} \partial_\phi, \quad \bar{l}_0 = -\frac{1}{2} r \partial_r - \frac{i}{2} \partial_\phi .$$

Out of those, we can form the linear combinations

$$l_0 + \bar{l}_0 = -r \partial_r \quad \text{and} \quad i(l_0 - \bar{l}_0) = -\partial_\phi, \quad (2.13)$$

and so we see that $l_0 + \bar{l}_0$ is the generator for two-dimensional dilations and that $i(l_0 - \bar{l}_0)$ is the generator of rotations.

- Finally, the operator l_{+1} corresponds to Special Conformal Transformations which are translations for the variable $w = -\frac{1}{z}$. Indeed, $c l_1 z = -c z^2$ is the infinitesimal version of the transformations $z \mapsto \frac{z}{c z + 1}$ which corresponds to $w \mapsto w - c$.

In summary, we have argued that the operators $\{l_{-1}, l_0, l_{+1}\}$ generate transformations of the form

$$z \mapsto \frac{az + b}{cz + d} \quad \text{with} \quad a, b, c, d \in \mathbb{C}. \quad (2.14)$$

For this transformation to be invertible, we have to require that $ad - bc$ is non-zero. If this is the case, we can scale the constants a, b, c, d such that $ad - bc = 1$. Furthermore, note that the expression above is invariant under $(a, b, c, d) \mapsto (-a, -b, -c, -d)$. From the conformal transformations (2.14) together with these restrictions, we can then infer that

The conformal group of the Riemann sphere $S^2 = \mathbb{C} \cup \infty$ is the Möbius group $SL(2, \mathbb{C})/\mathbb{Z}_2$.

Virasoro Algebra

Let us now come back to the Witt algebra of infinitesimal conformal transformations. As it turns out, this algebra admits a so-called central extension. Without providing a mathematically rigorous definition, we state that the central extension $\tilde{\mathfrak{g}} = \mathfrak{g} \oplus \mathbb{C}$ of a Lie algebra \mathfrak{g} by \mathbb{C} is characterised by the commutation relations

$$\begin{aligned} [\tilde{x}, \tilde{y}]_{\tilde{\mathfrak{g}}} &= [x, y]_{\mathfrak{g}} + c p(x, y), & \tilde{x}, \tilde{y} \in \tilde{\mathfrak{g}}, \\ [\tilde{x}, c]_{\tilde{\mathfrak{g}}} &= 0, & x, y \in \mathfrak{g}, \\ [c, c]_{\tilde{\mathfrak{g}}} &= 0, & c \in \mathbb{C}, \end{aligned}$$

where $p : \mathfrak{g} \times \mathfrak{g} \rightarrow \mathbb{C}$ is bilinear. Central extensions of algebras are closely related to projective representations which are common to Quantum Mechanics. In the following, we are going to allow for such additional structure.

More concretely, let us denote the elements of the central extension of the Witt algebra by L_n with $n \in \mathbb{Z}$ and write their commutation relations as

$$[L_m, L_n] = (m - n) L_{m+n} + cp(m, n). \quad (2.15)$$

Of course, a similar analysis can be carried out for the generators $\bar{L}_n \leftrightarrow \bar{L}_n$. The precise form of $p(m, n)$ is determined in the following way:

- First, from Eq. (2.15) it is clear that $p(m, n) = -p(n, m)$ in order for $p(m, n)$ to be compatible with the anti-symmetry of the Lie bracket.
- We also observe that one can always arrange for $p(1, -1) = 0$ and $p(n, 0) = 0$ by a redefinition

$$\hat{L}_n = L_n + \frac{cp(n, 0)}{n} \quad \text{for} \quad n \neq 0, \quad \hat{L}_0 = L_0 + \frac{cp(1, -1)}{2}.$$

Indeed, for the modified generators we see that the $p(n, m)$ vanishes

$$\begin{aligned} [\widehat{L}_n, \widehat{L}_0] &= n L_n + cp(n, 0) = n \widehat{L}_n, \\ [\widehat{L}_1, \widehat{L}_{-1}] &= 2 L_0 + cp(1, -1) = 2 \widehat{L}_0. \end{aligned}$$

- Next, we compute the following particular Jacobi identity:

$$\begin{aligned} 0 &= [[L_m, L_n], L_0] + [[L_n, L_0], L_m] + [[L_0, L_m], L_n] \\ 0 &= (m - n) cp(m + n, 0) + n cp(n, m) - m cp(m, n) \\ 0 &= (m + n) p(n, m) \end{aligned}$$

from which we infer that in the case $n \neq -m$, we have $p(n, m) = 0$. Therefore, the only non-vanishing central extensions are $p(n, -n)$ for $|n| \geq 2$.

- We finally calculate the following Jacobi identity:

$$\begin{aligned} 0 &= [[L_{-n+1}, L_n], L_{-1}] + [[L_n, L_{-1}], L_{-n+1}] + [[L_{-1}, L_{-n+1}], L_n] \\ 0 &= (-2n + 1) cp(1, -1) + (n + 1) cp(n - 1, -n + 1) + (n - 2) cp(-n, n) \end{aligned}$$

which leads to a recursion relation of the form

$$\begin{aligned} p(n, -n) &= \frac{n + 1}{n - 2} p(n - 1, -n + 1) = \dots \\ &= \frac{1}{2} \binom{n + 1}{3} = \frac{1}{12} (n + 1)n(n - 1) \end{aligned}$$

where we have normalised $p(2, -2) = \frac{1}{2}$. This normalisation is chosen such that the constant c has a particular value for the standard example of the free boson which we will study in Sect. 2.9.1.

The central extension of the Witt algebra is called the Virasoro algebra and the constant c is called the central charge. In summary,

The Virasoro algebra Vir_c with central charge c has the commutation relations

$$[L_m, L_n] = (m - n) L_{m+n} + \frac{c}{12} (m^3 - m) \delta_{m+n,0}. \quad (2.16)$$

Remarks

- Without providing a rigorous mathematical definition, we note that above we have computed the second cohomology group H^2 of the Witt algebra. It is generally true that $H^2(\mathfrak{g}, \mathbb{C})$ classifies the central extensions of an algebra \mathfrak{g} modulo redefinitions of the generators. However, for semi-simple finite dimensional Lie algebras, one finds that their second cohomology group vanishes and so in this case there do not exist any central extensions.

- Since $p(m, n) = 0$ for $m, n = -1, 0, +1$, it is still true that L_{-1} generates translations, L_0 generates dilations and rotations, and that L_{+1} generates Special Conformal Transformations. Therefore, also $\{L_{-1}, L_0, L_1\}$ are generators of $SL(2, \mathbb{C})/\mathbb{Z}_2$ transformations. This just reflects the above mentioned fact that the finite-dimensional Lie algebras do not have any non-trivial central extensions.
- By computing $\|L_{-m}|0\rangle\|^2 = \langle 0|L_{+m}L_{-m}|0\rangle = \frac{c}{12}(m^3 - m)$, one observes that only for $c \neq 0$ there exist non-trivial representations of the Virasoro algebra. We have not yet provided the necessary techniques to perform this calculation but we will do so in the rest of this chapter.
- In this section, we have determined the conformal transformations and the conformal algebra for two-dimensional Euclidean space. However, for a two-dimensional flat space–time with Lorentzian signature, one can perform a similar analysis. To do so, one defines light-cone coordinates $u = -t + x$ and $v = +t + x$ where t denotes the time direction and x the space direction. In these variables, we find

$$ds^2 = -dt^2 + dx^2 = du dv ,$$

and conformal transformations are given by $u \mapsto f(u)$ and $v \mapsto g(v)$ leading to $ds'^2 = \partial_u f \partial_v g du dv$. Therefore, the algebra of infinitesimal conformal transformations is again infinite dimensional.

2.2 Primary Fields

In this section, we will establish some basic definitions for two-dimensional conformal field theories in Euclidean space.

Complexification

Let us start with an Euclidean two-dimensional space \mathbb{R}^2 and perform the natural identification $\mathbb{R}^2 \simeq \mathbb{C}$ by introducing complex variables $z = x^0 + ix^1$ and $\bar{z} = x^0 - ix^1$. From Eq. (2.12), we have seen that we can identify two commuting copies of the Witt algebra which naturally extend to the Virasoro algebra. Since the generators of the Witt algebras are expressed in terms of z and \bar{z} , it turns out to be convenient to consider them as two independent complex variables. For the fields ϕ of our theory, this complexification $\mathbb{R}^2 \rightarrow \mathbb{C}^2$ means

$$\phi(x^0, x^1) \longrightarrow \phi(z, \bar{z}) ,$$

where $\{x^0, x^1\} \in \mathbb{R}^2$ and $\{z, \bar{z}\} \in \mathbb{C}^2$. However, note that at some point we have to identify \bar{z} with the complex conjugate z^* of z .

Definition of Chiral and Primary Fields

Definition 3. Fields only depending on z , i.e. $\phi(z)$, are called chiral fields and fields $\phi(\bar{z})$ only depending on \bar{z} are called anti-chiral fields. It is also common to use the terminology holomorphic and anti-holomorphic in order to distinguish between chiral and anti-chiral quantities.

Definition 4. If a field $\phi(z, \bar{z})$ transforms under scalings $z \mapsto \lambda z$ according to

$$\phi(z, \bar{z}) \mapsto \phi'(z, \bar{z}) = \lambda^h \bar{\lambda}^{\bar{h}} \phi(\lambda z, \bar{\lambda} \bar{z}) ,$$

it is said to have conformal dimensions (h, \bar{h}) .

Definition 5. If a field transforms under conformal transformations $z \mapsto f(z)$ according to

$$\phi(z, \bar{z}) \mapsto \phi'(z, \bar{z}) = \left(\frac{\partial f}{\partial z} \right)^h \left(\frac{\partial \bar{f}}{\partial \bar{z}} \right)^{\bar{h}} \phi(f(z), \bar{f}(\bar{z})) , \quad (2.17)$$

it is called a primary field of conformal dimension (h, \bar{h}) . If Eq. (2.17) holds only for $f \in SL(2, \mathbb{C})/\mathbb{Z}_2$, i.e. only for global conformal transformations, then ϕ is called a quasi-primary field.

Note that a primary field is always quasi-primary but the reverse is not true. Furthermore, not all fields in a CFT are primary or quasi-primary. Those fields are called secondary fields.

Infinitesimal Conformal Transformations of Primary Fields

Let us now investigate how a primary field $\phi(z, \bar{z})$ behaves under infinitesimal conformal transformations. To do so, we consider the map $f(z) = z + \epsilon(z)$ with $\epsilon(z) \ll 1$ and compute the following quantities up to first order in $\epsilon(z)$:

$$\left(\frac{\partial f}{\partial z} \right)^h = 1 + h \partial_z \epsilon(z) + \mathcal{O}(\epsilon^2) ,$$

$$\phi(z + \epsilon(z), \bar{z}) = \phi(z) + \epsilon(z) \partial_z \phi(z, \bar{z}) + \mathcal{O}(\epsilon^2) .$$

Using these two expressions in the definition of a primary field (2.17), we obtain

$$\phi(z, \bar{z}) \mapsto \phi(z, \bar{z}) + \left(h \partial_z \epsilon + \epsilon \partial_z + \bar{h} \partial_{\bar{z}} \bar{\epsilon} + \bar{\epsilon} \partial_{\bar{z}} \right) \phi(z, \bar{z}) ,$$

and so the transformation of a primary field under infinitesimal conformal transformations reads

$$\delta_{\epsilon, \bar{\epsilon}} \phi(z, \bar{z}) = \left(h \partial_z \epsilon + \epsilon \partial_z + \bar{h} \partial_{\bar{z}} \bar{\epsilon} + \bar{\epsilon} \partial_{\bar{z}} \right) \phi(z, \bar{z}) . \quad (2.18)$$

2.3 The Energy–Momentum Tensor

Usually, a Field Theory is defined in terms of a Lagrangian action from which one can derive various objects and properties of the theory. In particular, the energy–momentum tensor can be deduced from the variation of the action with respect to the metric and so it encodes the behaviour of the theory under infinitesimal transformations $g_{\mu\nu} \mapsto g_{\mu\nu} + \delta g_{\mu\nu}$ with $\delta g_{\mu\nu} \ll 1$.

Since the algebra of infinitesimal conformal transformations in two dimensions is infinite dimensional, there are strong constraints on a conformal field theory. In particular, it turns out to be possible to study such a theory without knowing the explicit form of the action. The only information needed is the behaviour under conformal transformations which is encoded in the energy–momentum tensor.

Implication of Conformal Invariance

In order to study the energy–momentum tensor for CFTs, let us recall Noether’s theorem which states that for every continuous symmetry in a Field Theory, there is a current j_μ which is conserved, i.e. $\partial^\mu j_\mu = 0$. Since we are interested in theories with a conformal symmetry $x^\mu \mapsto x^\mu + \epsilon^\mu(x)$, we have a conserved current which can be written as

$$j_\mu = T_{\mu\nu} \epsilon^\nu, \quad (2.19)$$

where the tensor $T_{\mu\nu}$ is symmetric and is called the energy–momentum tensor. Since this current is preserved, we obtain for the special case $\epsilon^\mu = \text{const.}$ that

$$0 = \partial^\mu j_\mu = \partial^\mu (T_{\mu\nu} \epsilon^\nu) = (\partial^\mu T_{\mu\nu}) \epsilon^\nu \quad \Rightarrow \quad \partial^\mu T_{\mu\nu} = 0. \quad (2.20)$$

For more general transformations $\epsilon^\mu(x)$, the conservation of the current (2.19) implies the following relation:

$$\begin{aligned} 0 = \partial^\mu j_\mu &= (\partial^\mu T_{\mu\nu}) \epsilon^\nu + T_{\mu\nu} (\partial^\mu \epsilon^\nu) \\ &= 0 + \frac{1}{2} T_{\mu\nu} (\partial^\mu \epsilon^\nu + \partial^\nu \epsilon^\mu) = \frac{1}{2} T_{\mu\nu} \eta^{\mu\nu} (\partial \cdot \epsilon) \frac{2}{d} = \frac{1}{d} T_\mu{}^\mu (\partial \cdot \epsilon), \end{aligned}$$

where we used Eq. (2.3) and the fact that $T_{\mu\nu}$ is symmetric. Since this equation has to be true for arbitrary infinitesimal transformations $\epsilon(z)$, we conclude

In a conformal field theory, the energy–momentum tensor $T_{\mu\nu}$ is traceless, that is, $T_\mu{}^\mu = 0$.

Specialising to Two Euclidean Dimensions

Let us now investigate the consequences of a traceless energy–momentum tensor for two-dimensional CFTs in the case of Euclidean signature. To do so, we again perform the change of coordinates from the real to the complex ones shown on p. 12. Using then $T_{\mu\nu} = \frac{\partial x^\alpha}{\partial x^\mu} \frac{\partial x^\beta}{\partial x^\nu} T_{\alpha\beta}$ for $x^0 = \frac{1}{2}(z + \bar{z})$ and $x^1 = \frac{1}{2i}(z - \bar{z})$, we find

$$\begin{aligned} T_{zz} &= \frac{1}{4}(T_{00} - 2i T_{10} - T_{11}) , \\ T_{\bar{z}\bar{z}} &= \frac{1}{4}(T_{00} + 2i T_{10} - T_{11}) , \\ T_{z\bar{z}} = T_{\bar{z}z} &= \frac{1}{4}(T_{00} + T_{11}) = \frac{1}{4}T_{\mu}{}^{\mu} = 0 , \end{aligned}$$

where for $T_{z\bar{z}}$ we used that $\eta_{\mu\nu} = \text{diag}(+1, +1)$ together with $T_{\mu}{}^{\mu} = 0$. Employing the latter relation also for the left-hand side, we obtain

$$T_{zz} = \frac{1}{2}(T_{00} - i T_{10}) , \quad T_{\bar{z}\bar{z}} = \frac{1}{2}(T_{00} + i T_{10}) . \quad (2.21)$$

Using finally the condition for translational invariance (2.20), we find

$$\partial_0 T_{00} + \partial_1 T_{10} = 0 , \quad \partial_0 T_{01} + \partial_1 T_{11} = 0 , \quad (2.22)$$

from which it follows that

$$\begin{aligned} \partial_{\bar{z}} T_{zz} &= \frac{1}{4}(\partial_0 + i\partial_1)(T_{00} - iT_{10}) = \frac{1}{4}(\partial_0 T_{00} + \partial_1 T_{10} + i\partial_1 \underbrace{T_{00}}_{=-T_{11}} - i\partial_0 \underbrace{T_{10}}_{=T_{01}}) = 0 , \\ & \hspace{15em} = -T_{11} \hspace{1em} = T_{01} \end{aligned}$$

where we used Eq. (2.22) and $T_{\mu}{}^{\mu} = 0$. Similarly, one can show that $\partial_z T_{\bar{z}\bar{z}} = 0$ which leads us to the conclusion that

The two non-vanishing components of the energy–momentum tensor are a *chiral* and an *anti-chiral* field

$$T_{zz}(z, \bar{z}) =: T(z) , \quad T_{\bar{z}\bar{z}}(z, \bar{z}) =: \bar{T}(\bar{z}) .$$

2.4 Radial Quantisation

Motivation and Notation

In the following, we will focus our studies on conformal field theories defined on Euclidean two-dimensional flat space. Although this choice is arbitrary, for concreteness we denote the Euclidean time direction by x^0 and the Euclidean space

direction by x^1 . Furthermore, note that theories with a Lorentzian signature can be obtained from the Euclidean ones via a Wick rotation $x^0 \rightarrow ix^0$.

Next, we compactify the Euclidean space direction x^1 on a circle of radius R which we will mostly choose as $R = 1$. The CFT we obtain in this way is thus defined on a cylinder of infinite length for which we introduce the complex coordinate w defined as

$$w = x^0 + ix^1, \quad w \sim w + 2\pi i,$$

where we also indicated the periodic identification. Let us emphasise that the theory on the cylinder is the starting point for our following analysis. This is also natural from a string theory point of view, since the world-sheet of a closed string in Euclidean coordinates is a cylinder.

Mapping the Cylinder to the Complex Plane

After having explained our initial theory, we now introduce the concept of radial quantisation of a two-dimensional Euclidean CFT. To do so, we perform a change of variables by mapping the cylinder to the complex plane in order to employ the power of complex analysis. In particular, this mapping is achieved by

$$z = e^w = e^{x^0} \cdot e^{ix^1}, \quad (2.23)$$

which is a map from an infinite cylinder described by x^0 and x^1 to the complex plane described by z (see Fig. 2.3). The former time translations $x^0 \mapsto x^0 + a$ are then mapped to complex dilation $z \mapsto e^a z$ and the space translations $x^1 \mapsto x^1 + b$ are mapped to rotations $z \mapsto e^{ib} z$.

As it is known from Quantum Mechanics, the generator of time translations is the Hamiltonian which in the present case corresponds to the dilation operator.

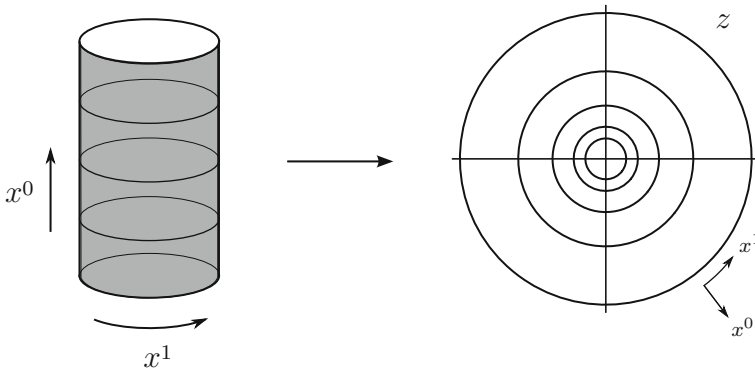

Fig. 2.3 Mapping the cylinder to the complex plane

Similarly, the generator for space translations is the momentum operator corresponding to rotations. Recalling Eq. (2.13) together with the observation that the central extension for L_0 and \bar{L}_0 vanishes, we find that

$$H = L_0 + \bar{L}_0, \quad P = i(L_0 - \bar{L}_0). \quad (2.24)$$

Asymptotic States

We now consider a field $\phi(z, \bar{z})$ with conformal dimensions (h, \bar{h}) for which we can perform a Laurent expansion around $z_0 = \bar{z}_0 = 0$

$$\phi(z, \bar{z}) = \sum_{n, \bar{m} \in \mathbb{Z}} z^{-n-h} \bar{z}^{-\bar{m}-\bar{h}} \phi_{n, \bar{m}}, \quad (2.25)$$

where the additional factors of h and \bar{h} in the exponents can be explained by the map (2.23), but also lead to scaling dimensions (n, \bar{m}) for $\phi_{n, \bar{m}}$. The quantisation of this field is achieved by promoting the Laurent modes $\phi_{n, \bar{m}}$ to operators. This procedure can be motivated by considering the theory on the cylinder and performing a Fourier expansion of $\phi(x^0, x^1)$. As usual, upon quantisation the Fourier modes are considered to be operators which, after mapping to the complex plane, agree with the approach above.

Next, we note that via Eq. (2.23) the infinite past on the cylinder $x^0 = -\infty$ is mapped to $z = \bar{z} = 0$. This motivates the definition of an asymptotic *in*-state $|\phi\rangle$ to be of the following form:

$$|\phi\rangle = \lim_{z, \bar{z} \rightarrow 0} \phi(z, \bar{z}) |0\rangle. \quad (2.26)$$

However, in order for Eq. (2.26) to be non-singular at $z = 0$, that is, to be a well-defined asymptotic *in*-state, we require

$$\phi_{n, \bar{m}} |0\rangle = 0 \quad \text{for} \quad n > -h, \quad \bar{m} > -\bar{h}. \quad (2.27)$$

Using this restriction together with the mode expansion (2.25), we can simplify Eq. (2.26) in the following way:

$$\boxed{|\phi\rangle = \lim_{z, \bar{z} \rightarrow 0} \phi(z, \bar{z}) |0\rangle = \phi_{-h, -\bar{h}} |0\rangle}. \quad (2.28)$$

Hermitian Conjugation

In order to obtain the hermitian conjugate ϕ^\dagger of a field ϕ , we note that in Euclidean space there is a non-trivial action on the Euclidean time $x^0 = it$ upon hermitian conjugation. Because of the complex conjugation, we find $x^0 \mapsto -x^0$ while the Euclidean space coordinate x^1 is left invariant. For the complex coordinate $z =$

$\exp(x^0 + ix^1)$, hermitian conjugation thus translates to $z \mapsto 1/\bar{z}$, where we identified \bar{z} with the complex conjugate z^* of z . We then define the hermitian conjugate of a field ϕ as

$$\phi^\dagger(z, \bar{z}) = \bar{z}^{-2h} z^{-2\bar{h}} \phi\left(\frac{1}{\bar{z}}, \frac{1}{z}\right). \quad (2.29)$$

Performing a Laurent expansion of the hermitian conjugate field ϕ^\dagger gives us the following result:

$$\phi^\dagger(z, \bar{z}) = \bar{z}^{-2h} z^{-2\bar{h}} \sum_{n, \bar{m} \in \mathbb{Z}} \bar{z}^{+n+h} z^{+\bar{m}+\bar{h}} \phi_{n, \bar{m}} = \sum_{n, \bar{m} \in \mathbb{Z}} \bar{z}^{+n-h} z^{+\bar{m}-\bar{h}} \phi_{n, \bar{m}}, \quad (2.30)$$

and if we compare this expression with the hermitian conjugate of Eq. (2.25), we see that for the Laurent modes we find

$$\boxed{(\phi_{n, \bar{m}})^\dagger = \phi_{-n, -\bar{m}}}. \quad (2.31)$$

Let us finally define a relation similar as Eq. (2.26) for an asymptotic *out*-states of a CFT. Naturally, this is achieved by using the hermitian conjugate field which reads

$$\langle \phi | = \lim_{z, \bar{z} \rightarrow 0} \langle 0 | \phi^\dagger(z, \bar{z}) = \lim_{\bar{w}, w \rightarrow \infty} w^{2h} \bar{w}^{2\bar{h}} \langle 0 | \phi(w, \bar{w}),$$

where we employed Eq. (2.29) together with $\bar{z} = w^{-1}$ and $z = \bar{w}^{-1}$. However, by the same reasoning as above, in order for the asymptotic *out*-state to be well defined, we require

$$\langle 0 | \phi_{n, \bar{m}} = 0 \quad \text{for} \quad n < h, \quad \bar{m} < \bar{h}.$$

Recalling for instance Eq. (2.30), we can then simplify the definition of the *out*-state as follows:

$$\boxed{\langle \phi | = \lim_{\bar{w}, w \rightarrow \infty} w^{2h} \bar{w}^{2\bar{h}} \langle 0 | \phi(w, \bar{w}) = \langle 0 | \phi_{+h, +\bar{h}}}. \quad (2.32)$$

2.5 The Operator Product Expansion

In this section, we will study in more detail the energy–momentum tensor and thereby introduce the operator formalism for two-dimensional conformal field theories.

Conserved Charges

To start, let us recall that since the current $j_\mu = T_{\mu\nu}\epsilon^\nu$ associated to the conformal symmetry is preserved, there exists a conserved charge which is expressed in the following way:

$$Q = \int dx^1 j_0 \quad \text{at} \quad x^0 = \text{const.} . \quad (2.33)$$

In Field Theory, this conserved charge is the generator of symmetry transformations for an operator A which can be written as

$$\delta A = [Q, A] ,$$

where the commutator is evaluated at equal times. From the change of coordinates (2.23), we infer that $x^0 = \text{const.}$ corresponds to $|z| = \text{const.}$ and so the integral over space $\int dx^1$ in Eq. (2.33) gets transformed into a contour integral. With the convention that contour integrals $\oint dz$ are always counter clockwise, the natural generalisation of the conserved charge (2.33) to complex coordinates reads

$$Q = \frac{1}{2\pi i} \oint_{\mathcal{C}} \left(dz T(z)\epsilon(z) + d\bar{z} \bar{T}(\bar{z})\bar{\epsilon}(\bar{z}) \right) . \quad (2.34)$$

This expression allows us now to determine the infinitesimal transformation of a field $\phi(z, \bar{z})$ generated by a conserved charge Q . To do so, we compute $\delta\phi = [Q, \phi]$ which, using Eq. (2.34), becomes

$$\delta_{\epsilon, \bar{\epsilon}} \phi(w, \bar{w}) = \frac{1}{2\pi i} \oint_{\mathcal{C}} dz [T(z)\epsilon(z), \phi(w, \bar{w})] + \frac{1}{2\pi i} \oint_{\mathcal{C}} d\bar{z} [\bar{T}(\bar{z})\bar{\epsilon}(\bar{z}), \phi(w, \bar{w})] . \quad (2.35)$$

Radial Ordering

Note that there is some ambiguity in Eq. (2.35) because we have to decide whether w and \bar{w} are inside or outside the contour \mathcal{C} . However, from quantum field theory we know that correlation functions are only defined as a time ordered product. Considering the change of coordinates (2.23), in a CFT the time ordering becomes a radial ordering and thus the product $A(z)B(w)$ does only make sense for $|z| > |w|$. To this end, we define the radial ordering of two operators as

$$R(A(z)B(w)) := \begin{cases} A(z)B(w) & \text{for } |z| > |w| , \\ B(w)A(z) & \text{for } |w| > |z| . \end{cases}$$

With this definition, it is clear that we have to interpret an expression such as Eq. (2.35) in the following way:

$$\begin{aligned} \oint dz [A(z), B(w)] &= \oint_{|z|>|w|} dz A(z) B(w) - \oint_{|z|<|w|} dz B(w) A(z) \\ &= \oint_{C(w)} dz R(A(z) B(w)), \end{aligned} \tag{2.36}$$

where we employed the relation among contour integrals shown in Fig. 2.4. With the help of this observation, we can express Eq. (2.35) as

$$\delta_{\epsilon, \bar{\epsilon}} \phi(w, \bar{w}) = \frac{1}{2\pi i} \oint_{C(w)} dz \epsilon(z) R(T(z)\phi(w, \bar{w})) + \text{anti-chiral}. \tag{2.37}$$

However, we have already computed this quantity for a primary field at the end of Sect. 2.2. By comparing with our previous result (2.18), that is,

$$\delta_{\epsilon, \bar{\epsilon}} \phi(w, \bar{w}) = h(\partial_w \epsilon(w)) \phi(w, \bar{w}) + \epsilon(w) (\partial_w \phi(w, \bar{w})) + \text{anti-chiral},$$

we can deduce a relation for the radial ordering of the energy–momentum tensor and a primary field. In particular, employing the identities

$$\begin{aligned} h(\partial_w \epsilon(w)) \phi(w, \bar{w}) &= \frac{1}{2\pi i} \oint_{C(w)} dz h \frac{\epsilon(z)}{(z-w)^2} \phi(w, \bar{w}), \\ \epsilon(w) (\partial_w \phi(w, \bar{w})) &= \frac{1}{2\pi i} \oint_{C(w)} dz \frac{\epsilon(z)}{z-w} \partial_w \phi(w, \bar{w}), \end{aligned} \tag{2.38}$$

for a bi-holomorphic field $\phi(w, \bar{w})$, we obtain that

$$R(T(z)\phi(w, \bar{w})) = \frac{h}{(z-w)^2} \phi(w, \bar{w}) + \frac{1}{z-w} \partial_w \phi(w, \bar{w}) + \dots, \tag{2.39}$$

where the ellipsis denote non-singular terms. An expression like (2.39) is called an *operator product expansion* (OPE) which defines an algebraic product structure on the space of quantum fields.

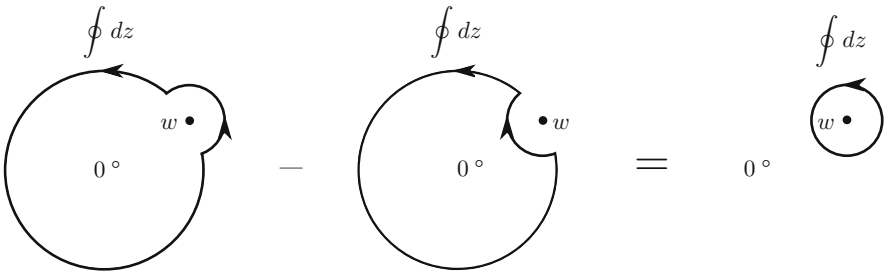

Fig. 2.4 Sum of contour integrals corresponding to Eq. (2.36)

To ease our notation, in the following, we will always assume radial ordering for a product of fields, i.e. we write $A(z)B(w)$ instead of $R(A(z)B(w))$. Furthermore, with the help of Eq. (2.39) we can give an alternative definition of a primary field:

Definition 6. A field $\phi(z, \bar{z})$ is called primary with conformal dimensions (h, \bar{h}) , if the operator product expansion between the energy–momentum tensors and $\phi(z, \bar{z})$ takes the following form:

$$\begin{aligned} T(z)\phi(w, \bar{w}) &= \frac{h}{(z-w)^2}\phi(w, \bar{w}) + \frac{1}{z-w}\partial_w\phi(w, \bar{w}) + \dots, \\ \bar{T}(\bar{z})\phi(w, \bar{w}) &= \frac{\bar{h}}{(\bar{z}-\bar{w})^2}\phi(w, \bar{w}) + \frac{1}{\bar{z}-\bar{w}}\partial_{\bar{w}}\phi(w, \bar{w}) + \dots, \end{aligned} \quad (2.40)$$

where the ellipsis denote non-singular terms.

Operator Product Expansion of the Energy–Momentum Tensor

After having defined the operator product expansion, let us now consider the example of the energy–momentum tensor. We first state that

The OPE of the chiral energy–momentum tensor with itself reads

$$T(z)T(w) = \frac{c/2}{(z-w)^4} + \frac{2T(w)}{(z-w)^2} + \frac{\partial_w T(w)}{z-w} + \dots \quad (2.41)$$

where c denotes the central charge and $|z| > |w|$.

A similar result holds for the anti-chiral part $\bar{T}(\bar{z})$, and the OPE $T(z)\bar{T}(\bar{w})$ contains only non-singular terms.

Let us now prove the statement (2.41). To do so, we perform a Laurent expansion of $T(z)$ in the following way:

$$T(z) = \sum_{n \in \mathbb{Z}} z^{-n-2} L_n \quad \text{where} \quad L_n = \frac{1}{2\pi i} \oint dz z^{n+1} T(z). \quad (2.42)$$

If we use this expansion for the conserved charge (2.34) and choose a particular conformal transformation $\epsilon(z) = -\epsilon_n z^{n+1}$, we find that

$$Q_n = \oint \frac{dz}{2\pi i} T(z) (-\epsilon_n z^{n+1}) = -\epsilon_n \sum_{m \in \mathbb{Z}} \oint \frac{dz}{2\pi i} L_m z^{n-m-1} = -\epsilon_n L_n.$$

Referring to our discussion in Sect. 2.1.3, we can thus identify the Laurent modes L_m of the energy–momentum tensor (2.42) with the generators of infinitesimal conformal transformations. As such, they have to satisfy the Virasoro algebra for which

we calculate

$$\begin{aligned}
[L_m, L_n] &= \oint \frac{dz}{2\pi i} \oint \frac{dw}{2\pi i} z^{m+1} w^{n+1} [T(z), T(w)] \\
&= \oint_{\mathcal{C}(0)} \frac{dw}{2\pi i} w^{n+1} \oint_{\mathcal{C}(w)} \frac{dz}{2\pi i} z^{m+1} R(T(z)T(w)) \\
&= \oint_{\mathcal{C}(0)} \frac{dw}{2\pi i} w^{n+1} \oint_{\mathcal{C}(w)} \frac{dz}{2\pi i} z^{m+1} \left(\frac{c/2}{(z-w)^4} + \frac{2T(w)}{(z-w)^2} + \frac{\partial_w T(w)}{z-w} \right) \\
&= \oint_{\mathcal{C}(0)} \frac{dw}{2\pi i} w^{n+1} \left((m+1)m(m-1) w^{m-2} \frac{c}{2 \cdot 3!} \right. \\
&\quad \left. + 2(m+1) w^m T(w) + w^{m+1} \partial_w T(w) \right) \\
&= \oint \frac{dw}{2\pi i} \left(\frac{c}{12} (m^3 - m) w^{m+n-1} \right. \\
&\quad \left. + 2(m+1) w^{m+n+1} T(w) + w^{m+n+2} \partial_w T(w) \right) \\
&= \frac{c}{12} (m^3 - m) \delta_{m,-n} + 2(m+1) L_{m+n} \\
&\quad + 0 - \underbrace{\oint \frac{dw}{2\pi i} (m+n+2) T(w) w^{m+n+1}}_{= (m+n+2) L_{m+n}} \\
&= (m-n) L_{m+n} + \frac{c}{12} (m^3 - m) \delta_{m,-n} ,
\end{aligned}$$

where we performed an integration by parts to evaluate the $\partial_w T(w)$ term. Therefore, we have shown that Eq. (2.41) is the correct form of the OPE between two energy-momentum tensors.

Conformal Transformations of the Energy–Momentum Tensor

To end this section, we will investigate the behaviour of the energy–momentum tensor under conformal transformations. In particular, by comparing the OPE (2.41) with the definition (2.40), we see that for non-vanishing central charges, $T(z)$ is not a primary field. But, one can show that under conformal transformations $f(z)$, the energy–momentum tensor behaves as

$$T'(z) = \left(\frac{\partial f}{\partial z} \right)^2 T(f(z)) + \frac{c}{12} S(f(z), z) , \quad (2.43)$$

where $S(w, z)$ denotes the Schwarzian derivative

$$S(w, z) = \frac{1}{(\partial_z w)^2} \left((\partial_z w)(\partial_z^3 w) - \frac{3}{2} (\partial_z^2 w)^2 \right).$$

We will not prove Eq. (2.43) in detail but verify it on the level of infinitesimal conformal transformations $f(z) = z + \epsilon(z)$. In order to do so, we first use Eq. (2.37) with the OPE of the energy–momentum tensor (2.41) to find

$$\begin{aligned} \delta_\epsilon T(z) &= \frac{1}{2\pi i} \oint_{\mathcal{C}(z)} dw \epsilon(w) T(w) T(z) \\ &= \frac{1}{2\pi i} \oint_{\mathcal{C}(z)} dw \epsilon(w) \left(\frac{c/2}{(w-z)^4} + \frac{2T(z)}{(w-z)^2} + \frac{\partial_z T(z)}{w-z} + \dots \right) \\ &= \frac{c}{12} \partial_z^3 \epsilon(z) + 2T(z) \partial_z \epsilon(z) + \epsilon(z) \partial_z T(z). \end{aligned} \quad (2.44)$$

Let us compare this expression with Eq. (2.43). For infinitesimal transformations $f(z) = z + \epsilon(z)$, the leading order contribution to the Schwarzian derivative reads

$$S(z + \epsilon(z), z) = \frac{1}{(1 + \partial_z \epsilon)^2} \left((1 + \partial_z \epsilon) \partial_z^3 \epsilon - \frac{3}{2} (\partial_z^2 \epsilon)^2 \right) \simeq \partial_z^3 \epsilon(z).$$

The variation of the energy–momentum tensor can then be computed as

$$\begin{aligned} \delta_\epsilon T(z) &= T'(z) - T(z) \\ &= \left(1 + \partial_z \epsilon(z) \right)^2 \left(T(z) + \epsilon(z) \partial_z T(z) \right) + \frac{c}{12} \partial_z^3 \epsilon(z) - T(z) \\ &= \frac{c}{12} \partial_z^3 \epsilon(z) + 2T(z) \partial_z \epsilon(z) + \epsilon(z) \partial_z T(z), \end{aligned}$$

which is the same as in Eq. (2.44). We have thus verified Eq. (2.43) at the level of infinitesimal conformal transformations.

Remarks

- The calculation on p. 27 shows that the *singular* part of the OPE of the chiral energy–momentum tensors $T(z)$ is equivalent to the Virasoro algebra for the modes L_m .
- Performing a computation along the same lines as on p. 27, one finds that for a chiral primary field $\phi(z)$, the holomorphic part of the OPE (2.40) is equivalent to

$$\boxed{[L_m, \phi_n] = ((h-1)m - n) \phi_{m+n}} \quad (2.45)$$

for all $m, n \in \mathbb{Z}$. If relations (2.40) and (2.45) hold only for $m = -1, 0, +1$, then $\phi(z)$ is called a quasi-primary field.

- Applying the relation (2.45) to the Virasoro algebra (2.16) for values $m = -1, 0, +1$, we see that the chiral energy–momentum tensor is a quasi-primary field of conformal dimension $(h, \bar{h}) = (2, 0)$. In view of Eq. (2.25), this observation also explains the form of the Laurent expansion (2.42).
- It is worth to note that the Schwarzian derivative $S(w, z)$ vanishes for $SL(2, \mathbb{C})$ transformations $w = f(z)$ in agreement with the fact that $T(z)$ is a quasi-primary field.

2.6 Operator Algebra of Chiral Quasi-Primary Fields

The objects of interest in quantum field theories are n -point correlation functions which are usually computed in a perturbative approach via either canonical quantisation or the path integral method. In this section, we will see that the *exact* two- and three-point functions for certain fields in a conformal field theory are already determined by the symmetries. This will allow us to derive a general formula for the OPE among quasi-primary fields.

2.6.1 Conformal Ward Identity

In quantum field theory, so-called Ward identities are the quantum manifestation of symmetries. We will now derive such an identity for the conformal symmetry of two-dimensional CFTs on general grounds. For primary fields ϕ_i , we calculate

$$\begin{aligned}
 & \left\langle \oint \frac{dz}{2\pi i} \epsilon(z) T(z) \phi_1(w_1, \bar{w}_1) \dots \phi_N(w_N, \bar{w}_N) \right\rangle \\
 &= \sum_{i=1}^N \left\langle \phi_1(w_1, \bar{w}_1) \dots \left(\oint_{C(w_i)} \frac{dz}{2\pi i} \epsilon(z) T(z) \phi_i(w_i, \bar{w}_i) \right) \dots \phi_N(w_N, \bar{w}_N) \right\rangle \\
 &= \sum_{i=1}^N \left\langle \phi_1(w_1, \bar{w}_1) \dots \left(h_i \partial \epsilon(w_i) + \epsilon(w_i) \partial_{w_i} \right) \phi_i(w_i, \bar{w}_i) \dots \phi_N(w_N, \bar{w}_N) \right\rangle
 \end{aligned} \tag{2.46}$$

where we have applied the deformation of the contour integrals illustrated in Fig. 2.5 and used Eq. (2.37). Employing then the two relations shown in Eq. (2.38), we can write

$$\begin{aligned}
 0 = \oint \frac{dz}{2\pi i} \epsilon(z) & \left[\left\langle T(z) \phi_1(w_1, \bar{w}_1) \dots \phi_N(w_N, \bar{w}_N) \right\rangle \right. \\
 & \left. - \sum_{i=1}^N \left(\frac{h_i}{(z-w_i)^2} + \frac{1}{z-w_i} \partial_{w_i} \right) \left\langle \phi_1(w_1, \bar{w}_1) \dots \phi_N(w_N, \bar{w}_N) \right\rangle \right]
 \end{aligned} \tag{2.47}$$

Since this must hold for all $\epsilon(z)$ of the form $\epsilon(z) = -z^{n+1}$ with $n \in \mathbb{Z}$, the integrand must already vanish and we arrive at the Conformal Ward identity

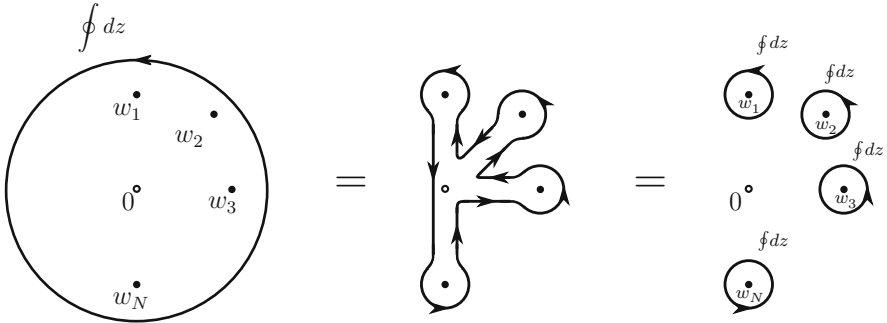

Fig. 2.5 Deformation of contour integrals

$$\left\langle T(z) \phi_1(w_1, \bar{w}_1) \dots \phi_N(w_N, \bar{w}_N) \right\rangle = \sum_{i=1}^N \left(\frac{h_i}{(z - w_i)^2} + \frac{1}{z - w_i} \partial_{w_i} \right) \left\langle \phi_1(w_1, \bar{w}_1) \dots \phi_N(w_N, \bar{w}_N) \right\rangle . \tag{2.48}$$

2.6.2 Two- and Three-Point Functions

In this subsection, we will employ the global conformal $SL(2, \mathbb{C})/\mathbb{Z}_2$ symmetry to determine the two- and three-point function for chiral quasi-primary fields.

The Two-Point Function

We start with the two-point function of two chiral quasi-primary fields

$$\langle \phi_1(z) \phi_2(w) \rangle = g(z, w) .$$

The invariance under translations $f(z) = z + a$ generated by L_{-1} requires g to be of the form $g(z, w) = g(z - w)$. The invariance under L_0 , i.e. rescalings of the form $f(z) = \lambda z$, implies that

$$\langle \phi_1(z) \phi_2(w) \rangle \rightarrow \langle \lambda^{h_1} \phi_1(\lambda z) \lambda^{h_2} \phi_2(\lambda w) \rangle = \lambda^{h_1+h_2} g(\lambda(z - w)) \stackrel{!}{=} g(z - w) ,$$

from which we conclude

$$g(z - w) = \frac{d_{12}}{(z - w)^{h_1+h_2}} ,$$

where d_{12} is called a structure constant. Finally, the invariance of the two-point function under L_1 essentially implies the invariance under transformations $f(z) = -\frac{1}{z}$ for which we find

$$\begin{aligned} \langle \phi_1(z) \phi_2(w) \rangle &\rightarrow \left\langle \frac{1}{z^{2h_1}} \frac{1}{w^{2h_2}} \phi_1\left(-\frac{1}{z}\right) \phi_2\left(-\frac{1}{w}\right) \right\rangle \\ &= \frac{1}{z^{2h_1} w^{2h_2}} \frac{d_{12}}{\left(-\frac{1}{z} + \frac{1}{w}\right)^{h_1+h_2}} \\ &\stackrel{!}{=} \frac{d_{12}}{(z-w)^{h_1+h_2}} \end{aligned}$$

which can only be satisfied if $h_1 = h_2$. We therefore arrive at the result that

The $SL(2, \mathbb{C})/\mathbb{Z}_2$ conformal symmetry fixes the two-point function of two chiral quasi-primary fields to be of the form

$$\langle \phi_i(z) \phi_j(w) \rangle = \frac{d_{ij} \delta_{h_i, h_j}}{(z-w)^{2h_i}}. \quad (2.49)$$

As an example, let us consider the energy–momentum tensor $T(z)$. From the OPE shown in Eq. (2.41) (and using the fact that one-point functions of conformal fields on the sphere vanish), we find that

$$\langle T(z) T(w) \rangle = \frac{c/2}{(z-w)^4}.$$

The Three-Point Function

After having determined the two-point function of two chiral quasi-primary fields up to a constant, let us now consider the three-point function. From the invariance under translations, we can infer that

$$\langle \phi_1(z_1) \phi_2(z_2) \phi_3(z_3) \rangle = f(z_{12}, z_{23}, z_{13}),$$

where we introduced $z_{ij} = z_i - z_j$. The requirement of invariance under dilation can be expressed as

$$\begin{aligned} \langle \phi_1(z_1) \phi_2(z_2) \phi_3(z_3) \rangle &\rightarrow \langle \lambda^{h_1} \phi_1(\lambda z_1) \lambda^{h_2} \phi_2(\lambda z_2) \lambda^{h_3} \phi_3(\lambda z_3) \rangle \\ &= \lambda^{h_1+h_2+h_3} f(\lambda z_{12}, \lambda z_{23}, \lambda z_{13}) \\ &\stackrel{!}{=} f(z_{12}, z_{23}, z_{13}) \end{aligned}$$

from which it follows that

$$f(z_{12}, z_{23}, z_{13}) = \frac{C_{123}}{z_{12}^a z_{23}^b z_{13}^c},$$

with $a + b + c = h_1 + h_2 + h_3$ and C_{123} some structure constant. Finally, from the Special Conformal Transformations, we obtain the condition

$$\frac{1}{z_1^{2h_1} z_2^{2h_2} z_3^{2h_3}} \frac{(z_1 z_2)^a (z_2 z_3)^b (z_1 z_3)^c}{z_{12}^a z_{23}^b z_{13}^c} = \frac{1}{z_{12}^a z_{23}^b z_{13}^c}.$$

Solving this expression for a, b, c leads to

$$a = h_1 + h_2 - h_3, \quad b = h_2 + h_3 - h_1, \quad c = h_1 + h_3 - h_2,$$

and so we have shown that

The $SL(2, \mathbb{C})/\mathbb{Z}_2$ conformal symmetry fixes the three-point function of chiral quasi-primary fields up to a constant to

$$\langle \phi_1(z_1) \phi_2(z_2) \phi_3(z_3) \rangle = \frac{C_{123}}{z_{12}^{h_1+h_2-h_3} z_{23}^{h_2+h_3-h_1} z_{13}^{h_1+h_3-h_2}}. \quad (2.50)$$

Remarks

- Using the $SL(2, \mathbb{C})/\mathbb{Z}_2$ global symmetry, it is possible to map any three points $\{z_1, z_2, z_3\}$ on the Riemann sphere to $\{0, 1, \infty\}$.
- The results for the two- and three-point function have been derived using only the $SL(2, \mathbb{C})/\mathbb{Z}_2 \simeq SO(3, 1)$ symmetry. As we have mentioned before, the conformal group $SO(3, 1)$ extends to higher dimensions $\mathbb{R}^{d,0}$ as $SO(d+1, 1)$. By analogous reasoning, the two- and three-point functions for CFTs in dimensions $d > 2$ then have the same form as for $d = 2$.
- In order for the two-point function (2.49) to be single-valued on the complex plane, that is, to be invariant under rotations $z \mapsto e^{2\pi i} z$, we see that the conformal dimension of a chiral quasi-primary field has to be integer or half-integer.

2.6.3 General Form of the OPE for Chiral Quasi-Primary Fields

General Expression for the OPE

The generic form of the two- and three-point functions allows us to extract the general form of the OPE between two chiral quasi-primary fields in terms of other

quasi-primary fields and their derivatives¹. To this end we make the ansatz

$$\phi_i(z) \phi_j(w) = \sum_{k,n \geq 0} C_{ij}^k \frac{a_{ijk}^n}{n!} \frac{1}{(z-w)^{h_i+h_j-h_k-n}} \partial^n \phi_k(w), \quad (2.51)$$

where the $(z-w)$ part is fixed by the scaling behaviour under dilations $z \mapsto \lambda z$. Note that we have chosen our ansatz such that a_{ijk}^n only depends on the conformal weights h_i, h_j, h_k of the fields i, j, k (and on n), while C_{ij}^k contains further information about the fields.

Let us now take $w = 1$ in Eq. (2.51) and consider it as part of the following three-point function:

$$\left\langle \left(\phi_i(z) \phi_j(1) \right) \phi_k(0) \right\rangle = \sum_{l,n \geq 0} C_{ij}^l \frac{a_{ijl}^n}{n!} \frac{1}{(z-1)^{h_i+h_j-h_l-n}} \langle \partial^n \phi_l(1) \phi_k(0) \rangle.$$

Using then the general formula for the two-point function (2.49), we find for the correlator on the right-hand side that

$$\left\langle \partial_z^n \phi_l(z) \phi_k(0) \right\rangle \Big|_{z=1} = \partial_z^n \left(\frac{d_{lk} \delta_{h_l, h_k}}{z^{2h_k}} \right) \Big|_{z=1} = (-1)^n n! \binom{2h_k + n - 1}{n} d_{lk} \delta_{h_l, h_k}.$$

We therefore obtain

$$\left\langle \phi_i(z) \phi_j(1) \phi_k(0) \right\rangle = \sum_{l,n \geq 0} C_{ij}^l d_{lk} a_{ijk}^n \binom{2h_k + n - 1}{n} \frac{(-1)^n}{(z-1)^{h_i+h_j-h_k-n}}. \quad (2.52)$$

However, we can also use the general expression for the three-point function (2.50) with values $z_1 = z, z_2 = 1$ and $z_3 = 0$. Combining then Eq. (2.50) with Eq. (2.52), we find

$$\begin{aligned} \sum_{l,n \geq 0} C_{ij}^l d_{lk} a_{ijk}^n \binom{2h_k + n - 1}{n} \frac{(-1)^n}{(z-1)^{h_i+h_j-h_k-n}} &\stackrel{!}{=} \frac{C_{ijk}}{(z-1)^{h_i+h_j-h_k} z^{h_i+h_k-h_j}}, \\ \sum_{l,n \geq 0} C_{ij}^l d_{lk} a_{ijk}^n \binom{2h_k + n - 1}{n} (-1)^n (z-1)^n &\stackrel{!}{=} \frac{C_{ijk}}{(1+(z-1))^{h_i+h_k-h_j}}. \end{aligned}$$

Finally, we use the following relation with $x = z - 1$ for the term on the right-hand side of the last formula:

¹ The proof that the OPE of two quasi-primary fields involves indeed *just* other quasi-primary fields and their derivatives is non-trivial and will not be presented.

$$\frac{1}{(1+x)^H} = \sum_{n=0}^{\infty} (-1)^n \binom{H+n-1}{n} x^n .$$

Comparing coefficients in front of the $(z-1)$ terms, we can fix the constants C_{ij}^l and a_{ijk}^n and arrive at the result that

The OPE of two chiral quasi-primary fields has the general form

$$\phi_i(z) \phi_j(w) = \sum_{k,n \geq 0} C_{ij}^k \frac{a_{ijk}^n}{n!} \frac{1}{(z-w)^{h_i+h_j-h_k-n}} \partial^n \phi_k(w) \quad (2.53)$$

with coefficients

$$a_{ijk}^n = \binom{2h_k+n-1}{n}^{-1} \binom{h_k+h_i-h_j+n-1}{n} ,$$

$$C_{ijk} = C_{ij}^l d_{lk} .$$

General Expression for the Commutation Relations

The final expression (2.53) gives a general form for the OPE of chiral quasi-primary fields. However, as we have seen previously, the same information is encoded in the commutation relations of the Laurent modes of the fields. We will not derive these commutators but just summarise the result. To do so, we recall the Laurent expansion of chiral fields $\phi_i(z)$

$$\phi_i(z) = \sum_m \phi_{(i)m} z^{-m-h_i} ,$$

where the conformal dimensions h_i of a chiral quasi-primary field are always integer or half-integer. Note that here i is a label for the fields and $m \in \mathbb{Z}$ or $m \in \mathbb{Z} + \frac{1}{2}$ denotes a particular Laurent mode. After expressing the modes $\phi_{(i)m}$ as contour integrals over $\phi_i(z)$ and performing a tedious evaluation of the commutator, one arrives at the following compact expression for the algebra:

$$[\phi_{(i)m}, \phi_{(j)n}] = \sum_k C_{ij}^k p_{ijk}(m, n) \phi_{(k)m+n} + d_{ij} \delta_{m,-n} \binom{m+h_i-1}{2h_i-1} \quad (2.54)$$

with the polynomials

$$\begin{aligned}
p_{ijk}(m, n) &= \sum_{\substack{r, s \in \mathbb{Z}_0^+ \\ r+s=h_i+h_j-h_k-1}} C_{r,s}^{ijk} \cdot \binom{-m+h_i-1}{r} \cdot \binom{-n+h_j-1}{s}, \\
C_{r,s}^{ijk} &= (-1)^r \frac{(2h_k-1)!}{(h_i+h_j+h_k-2)!} \prod_{t=0}^{s-1} (2h_i-2-r-t) \prod_{u=0}^{r-1} (2h_j-2-s-u).
\end{aligned} \tag{2.55}$$

Remarks

- Note that on the right-hand side of Eq. (2.54), only fields with conformal dimension $h_k < h_i + h_j$ can appear. This can be seen by studying the coefficients (2.55).
- Furthermore, because the polynomials p_{ijk} depend only on the conformal dimensions h_i, h_j, h_k of the fields i, j, k , it is also common to use the conformal dimensions as subscripts, that is, $p_{h_i h_j h_k}$.
- The generic structure of the chiral algebra of quasi-primary fields (2.53) is extremely helpful for the construction of extended symmetry algebras. We will consider such so-called \mathcal{W} algebras in Sect. 3.7.
- Clearly, not all fields in a conformal field theory are quasi-primary and so the formulas above do not apply for all fields! For instance, the derivatives $\partial^n \phi_k(z)$ of a quasi-primary field $\phi(z)$ are not quasi-primary.

Applications I: Two-Point Function Revisited

Let us now consider four applications of the results obtained in this section. First, with the help of Eq. (2.54), we can compute the norm of a state $\phi_{(i)-n}|0\rangle$. Assuming $n \geq h$, we obtain

$$\begin{aligned}
\| \phi_{(i)-n}|0\rangle \|^2 &= \langle 0 | \phi_{(i)-n}^\dagger \phi_{(i)-n} | 0 \rangle \\
&= \langle 0 | \phi_{(i)+n} \phi_{(i)-n} | 0 \rangle \\
&= \langle 0 | [\phi_{(i)+n}, \phi_{(i)-n}] | 0 \rangle \\
&= C_{ii}^j p_{h_i, h_i, h_j}(n, -n) \langle 0 | \phi_{(j)0} | 0 \rangle + d_{ii} \binom{n+h_i-1}{2h_i-1} \\
&= d_{ii} \binom{n+h_i-1}{2h_i-1}.
\end{aligned}$$

Employing then Eq. (2.28) as well as Eq. (2.32), we see that the norm of a state $|\phi\rangle = \phi_{-h}|0\rangle$ is equal to the structure constant of the two-point function

$$\langle \phi | \phi \rangle = \langle 0 | \phi_{+h} \phi_{-h} | 0 \rangle = d_{\phi\phi}. \tag{2.56}$$

Applications II: Three-Point Function Revisited

Let us also determine the structure constant of the three-point function between chiral quasi-primary fields. To do so, we write Eq. (2.50) as

$$C_{123} = z_{12}^{h_1+h_2-h_3} z_{23}^{h_2+h_3-h_1} z_{13}^{h_1+h_3-h_2} \langle \phi_1(z_1) \phi_2(z_2) \phi_3(z_3) \rangle,$$

and perform the limits $z_1 \rightarrow \infty$, $z_3 \rightarrow 0$ while keeping z_2 finite. Using then again (2.28) as well as (2.32), we find

$$\begin{aligned} C_{123} &= \lim_{z_1 \rightarrow \infty} \lim_{z_3 \rightarrow 0} z_{12}^{h_1+h_2-h_3} z_{23}^{h_2+h_3-h_1} z_{13}^{h_1+h_3-h_2} \langle \phi_1(z_1) \phi_2(z_2) \phi_3(z_3) \rangle \\ &= \lim_{z_1 \rightarrow \infty} \lim_{z_3 \rightarrow 0} z_1^{2h_1} z_2^{h_2+h_3-h_1} \langle \phi_1(z_1) \phi_2(z_2) \phi_3(z_3) \rangle \\ &= z_2^{h_2+h_3-h_1} \langle 0 | \phi_{(1)+h_1} \phi_2(z_2) \phi_{(3)-h_3} | 0 \rangle. \end{aligned}$$

Because the left-hand side of this equation is a constant, the right-hand side cannot depend on z_2 and so only the z_2^0 term does give a non-trivial contribution. We therefore conclude that

$$C_{123} = \langle 0 | \phi_{(1)+h_1} \phi_{(2)h_3-h_1} \phi_{(3)-h_3} | 0 \rangle. \quad (2.57)$$

Applications III: Virasoro Algebra

After studying the two- and three-point function, let us now turn to the Virasoro algebra and determine the structure constants C_{ij}^k and d_{ij} . From the general expression (2.54), we infer the commutation relations between the Laurent modes of the energy-momentum tensor to be of the following form:

$$[L_m, L_n] = C_{LL}^L p_{222}(m, n) L_{m+n} + d_{LL} \delta_{m, -n} \binom{m+1}{3},$$

where in view of the final result, we identified $C_{LL}^k = 0$ for $k \neq L$. Note also that the subscripts of p_{ijk} denote the conformal weight of the chiral fields involved. Using the explicit expression (2.55) for p_{ijk} and recalling from p. 29 that the conformal dimension of $T(z)$ is $h = 2$, we find

$$p_{222}(m, n) = C_{1,0}^{222} \binom{-m+1}{1} + C_{0,1}^{222} \binom{-n+1}{1}$$

with coefficients $C_{r,s}^{222}$ of the form

$$C_{1,0}^{222} = (-1)^1 \cdot \frac{3!}{4!} \cdot 2 = -\frac{1}{2} \quad \text{and} \quad C_{0,1}^{222} = (-1)^0 \cdot \frac{3!}{4!} \cdot 2 = +\frac{1}{2}.$$

Putting these results together, we obtain for the Virasoro algebra

$$[L_m, L_n] = C_{LL}^L \frac{m-n}{2} L_{m+n} + d_{LL} \delta_{m,-n} \frac{m^3 - m}{6} .$$

If we compare with Eq. (2.16), we can fix the two unknown constants as

$$d_{LL} = \frac{c}{2}, \quad C_{LL}^L = 2 . \quad (2.58)$$

Applications IV: Current Algebras

Finally, let us study the so-called current algebras. The definition of a current in a two-dimensional conformal field theory is the following:

Definition 7. *A chiral field $j(z)$ with conformal dimension $h = 1$ is called a current. A similar definition holds for the anti-chiral sector.*

Let us assume we have a theory with N quasi-primary currents $j_i(z)$ where $i = 1, \dots, N$. We can express these fields as a Laurent series $j_i(z) = \sum_{n \in \mathbb{Z}} z^{-n-1} j_{(i)n}$ in the usual way and determine the algebra of the Laurent modes $j_{(i)n}$ using Eq. (2.54)

$$[j_{(i)m}, j_{(j)n}] = \sum_k C_{ij}^k p_{111}(m, n) j_{(k)m+n} + d_{ij} m \delta_{m,-n} . \quad (2.59)$$

From Eq. (2.55), we compute $p_{111}(m, n) = 1$ and so it follows that $C_{ij}^k = -C_{ji}^k$ due to the anti-symmetry of the commutator.

Next, we perform a rotation among the fields such that the matrix d_{ij} is diagonalised, and by a rescaling of the fields we can achieve $d_{ij} \rightarrow k \delta_{ij}$ where k is some constant. Changing then the labels of the fields from subscript to superscript and denoting the constants C_{ij}^k in the new basis by f^{ijk} , we can express the algebra Eq. (2.59) as

$$[j_m^i, j_n^j] = \sum_l f^{ijl} j_{m+n}^l + k m \delta^{ij} \delta_{m,-n} , \quad (2.60)$$

where f^{ijl} are called structure constants and k is called the level. As it turns out, the algebra (2.60) is a generalisation of a Lie algebra called a *Kač–Moody algebra* which is infinite dimensional. conformal field theories based on such algebras provide many examples of abstract CFTs which we will study in much more detail in Chap. 3.

2.7 Normal Ordered Products

Operations on the field space of a theory are provided by the action of derivatives $\partial\phi_i, \partial^2\phi_i, \dots$ and by taking products of fields at the same point in space–time. As known from quantum field theory, since the ϕ_i are operators, we need to give an

ordering prescription for such products. This will be *normal ordering* which in QFT language means “creation operators to the left”.

In this section, we will illustrate that the regular part of an OPE provides a notion of normal ordering for the product fields.

Normal Ordering Prescription

Let us start by investigating what are the creation and what are the annihilation operators in a CFT. To do so, we recall Eq. (2.27) which reads

$$\phi_{n,\bar{m}} |0\rangle = 0 \quad \text{for} \quad n > -h, \quad \bar{m} > -\bar{h}. \quad (2.61)$$

From here we can see already that we can interpret operators $\phi_{n,\bar{m}}$ with $n > -h$ or $\bar{m} > -\bar{h}$ as annihilation operators.

However, in order to explore this point further, let us recall from Eq. (2.24) that the Hamiltonian is expressed in terms of L_0 and \bar{L}_0 as $H = L_0 + \bar{L}_0$, which motivates the notion of “chiral energy” for the L_0 eigenvalue of a state. For the special case of a chiral primary, let us calculate

$$L_0 \phi_n |0\rangle = (L_0 \phi_n - \phi_n L_0) |0\rangle = [L_0, \phi_n] |0\rangle = -n \phi_n |0\rangle, \quad (2.62)$$

where we employed Eq. (2.45) as well as $L_0 |0\rangle = 0$. Taking into account (2.61), we see that the chiral energy is bounded from below, i.e. only values $(h + m)$ with $m \geq 0$ are allowed. Requiring that creation operators should create states with positive energy, we conclude that

$$\begin{aligned} \phi_n & \quad \text{with} \quad n > -h & \quad \text{are annihilation operators,} \\ \phi_n & \quad \text{with} \quad n \leq -h & \quad \text{are creation operators.} \end{aligned}$$

The anti-chiral sector can be included by following the same arguments for \bar{L}_0 . Coming then back to the subject of this paragraph, the normal ordering prescription is to put all creation operators to the left.

Normal Ordered Products and OPEs

After having discussed the normal ordering prescription for operators in a conformal field theory, let us state that

The regular part of an OPE naturally gives rise to normal ordered products (NOPs) which can be written in the following way:

$$\phi(z) \chi(w) = \text{sing.} + \sum_{n=0}^{\infty} \frac{(z-w)^n}{n!} N(\chi \partial^n \phi)(w). \quad (2.63)$$

The notation for normal ordering we will mainly employ is $N(\chi\phi)$, however, it is also common to use $:\phi\chi:$, $(\phi\chi)$ or $[\phi\chi]_0$. In the following, we will verify the statement above for the case $n = 0$.

Let us first use Eq. (2.63) to obtain an expression for the normal ordered product of two operators. To do so, we apply $\frac{1}{2\pi i} \oint dz (z-w)^{-1}$ to both sides of Eq. (2.63) which picks out the $n = 0$ term on the right-hand side leading to

$$N(\chi\phi)(w) = \oint_{\mathcal{C}(w)} \frac{dz}{2\pi i} \frac{\phi(z)\chi(w)}{z-w}. \quad (2.64)$$

However, we can also perform a Laurent expansion of $N(\chi\phi)$ in the usual way which gives us

$$\begin{aligned} N(\chi\phi)(w) &= \sum_{n \in \mathbb{Z}} w^{-n-h^\phi-h^\chi} N(\chi\phi)_n, \\ N(\chi\phi)_n &= \oint_{\mathcal{C}(0)} \frac{dw}{2\pi i} w^{n+h^\phi+h^\chi-1} N(\chi\phi)(w), \end{aligned} \quad (2.65)$$

where we also include the expression for the Laurent modes $N(\chi\phi)_n$. Let us now employ the relation (2.64) in Eq. (2.65) for which we find

$$\begin{aligned} N(\chi\phi)_n &= \oint_{\mathcal{C}(0)} \frac{dw}{2\pi i} w^{n+h^\phi+h^\chi-1} \oint_{\mathcal{C}(w)} \frac{dz}{2\pi i} \frac{\phi(z)\chi(w)}{z-w} \\ &= \underbrace{\oint_{|z|>|w|} \frac{dw}{2\pi i} w^{n+h^\phi+h^\chi-1} \left(\underbrace{\oint_{|z|>|w|} \frac{dz}{2\pi i} \frac{\phi(z)\chi(w)}{z-w}}_{\mathcal{I}_1} - \oint_{|z|<|w|} \frac{dz}{2\pi i} \frac{\chi(w)\phi(z)}{z-w} \right)}_{\mathcal{I}_2} \end{aligned} \quad (2.66)$$

where we applied the deformation of contour integrals formulated in Eq. (2.36). Expressing ϕ and χ as a Laurent series, the term \mathcal{I}_1 can be evaluated as

$$\begin{aligned} \mathcal{I}_1 &= \oint_{|z|>|w|} \frac{dz}{2\pi i} \frac{1}{z-w} \sum_{r,s} z^{-r-h^\phi} w^{-s-h^\chi} \phi_r \chi_s \\ &= \oint_{|z|>|w|} \frac{dz}{2\pi i} \frac{1}{z} \sum_{p \geq 0} \left(\frac{w}{z}\right)^p \sum_{r,s} z^{-r-h^\phi} w^{-s-h^\chi} \phi_r \chi_s \\ &= \oint_{|z|>|w|} \frac{dz}{2\pi i} \sum_{p \geq 0} \sum_{r,s} z^{-r-h^\phi-p-1} w^{-s-h^\chi+p} \phi_r \chi_s. \end{aligned}$$

Note that we employed $\frac{1}{z-w} = \frac{1}{z(1-w/z)}$ as well as the geometric series to go from the first to the second line and that only the z^{-1} term gives a non-zero contribution. Thus, performing the integral over dz leads to a δ -function setting $r = -h^\phi - p$ and

so the integral \mathcal{I}_2 reads

$$\mathcal{I}_2 = \oint \frac{dw}{2\pi i} \sum_{p \geq 0} \sum_s w^{-s-h^\chi+p+n+h^\phi+h^\chi-1} \phi_{-h^\phi-p} \chi_s ,$$

for which again only the w^{-1} term contributes and therefore $s = p + n + h^\phi$. We then arrive at the final expression for the first term in $N(\chi\phi)_n$

$$\mathcal{I}_2 = \sum_{p \geq 0} \phi_{-h^\phi-p} \chi_{h^\phi+n+p} = \sum_{k \leq -h^\phi} \phi_k \chi_{n-k} .$$

For the second term, we perform a similar calculation to find $\sum_{k > -h^\phi} \chi_{n-k} \phi_k$, which we combine into the final result for the Laurent modes of normal ordered products

$$\boxed{N(\chi\phi)_n = \sum_{k > -h^\phi} \chi_{n-k} \phi_k + \sum_{k \leq -h^\phi} \phi_k \chi_{n-k}} . \quad (2.67)$$

Here we see that indeed the ϕ_k in the first term are annihilation operators at the right and that the ϕ_k in the second term are creation operators at the left. Therefore, the regular part of an OPE contains normal ordered products.

Useful Formulas

For later reference, let us now consider a special case of a normal ordered product. In particular, let us compute $N(\chi\partial\phi)_n$ and $N(\partial\chi\phi)_n$ for which we note that the Laurent expansion of say $\partial\phi$ can be inferred from ϕ in the following way:

$$\partial\phi(z) = \partial \sum_n z^{-n-h} \phi_n = \sum_n (-n-h) z^{-n-(h+1)} \phi_n . \quad (2.68)$$

Replacing $\phi \rightarrow \partial\phi$ in Eq. (2.66), using the Laurent expansion (2.68) and performing the same steps as above, one arrives at the following results:

$$\begin{aligned} N(\chi\partial\phi)_n &= \sum_{k > -h^\phi-1} (-h^\phi-k) \chi_{n-k} \phi_k + \sum_{k \leq -h^\phi-1} (-h^\phi-k) \phi_k \chi_{n-k} , \\ N(\partial\chi\phi)_n &= \sum_{k > -h^\phi} (-h^\chi-n+k) \chi_{n-k} \phi_k + \sum_{k \leq -h^\phi} (-h^\chi-n+k) \phi_k \chi_{n-k} . \end{aligned} \quad (2.69)$$

Normal Ordered Products of Quasi-Primary Fields

Let us also note that normal ordered products of quasi-primary fields are in general not quasi-primary, but can be projected to such. To illustrate this statement, we consider the example of the energy-momentum tensor. Recalling the OPE (2.41)

together with Eq. (2.63), we can write

$$T(z)T(w) = \frac{c/2}{(z-w)^4} + \frac{2T(w)}{(z-w)^2} + \frac{\partial T(w)}{z-w} + N(TT)(w) + \dots \quad (2.70)$$

However, using the general expression for the OPE of two quasi-primary fields shown in Eq. (2.53), we observe that there is a $\partial^2 T$ term at $(z-w)^0$ with coefficient

$$C_{TT}^T \frac{a_{222}^2}{2!} \quad \text{where} \quad a_{222}^2 = \binom{5}{2}^{-1} \binom{3}{2} = \frac{3}{10} \quad \text{and} \quad C_{TT}^T = 2. \quad (2.71)$$

But, since the index k in Eq. (2.53) runs over all quasi-primary fields of the theory, we expect also other terms at order $(z-w)^0$. If we denote these by $\mathcal{N}(TT)$, we find from Eq. (2.70) that

$$N(TT) = \mathcal{N}(TT) + \frac{3}{10} \partial^2 T.$$

One can easily check that $\partial^2 T$ is not a quasi-primary field, and by computing for instance $[L_m, N(TT)_n]$ and comparing with Eq. (2.45), one arrives at the same conclusion for $N(TT)$. However, we note that

$$\boxed{\mathcal{N}(TT) = N(TT) - \frac{3}{10} \partial^2 T} \quad (2.72)$$

actually is a quasi-primary normal ordered product. Moreover, it turns out that this procedure can be iterated which allows one to write the entire field space in terms of quasi-primary fields and derivatives thereof.

2.8 The CFT Hilbert Space

In this section, we are going to summarise some general properties of the Hilbert space of a conformal field theory.

The Verma Module

Let us consider again the chiral energy–momentum tensor. For the Laurent expansions of $T(z)$ and $\partial T(z)$ as well as for the corresponding asymptotic *in*-states, we find

$$\begin{aligned}
T(z) &= \sum_{n \in \mathbb{Z}} z^{-n-2} L_n && \longleftrightarrow && L_{-2} |0\rangle, \\
\partial T(z) &= \sum_{n \in \mathbb{Z}} (-n-2) z^{-n-3} L_n && \longleftrightarrow && L_{-3} |0\rangle,
\end{aligned}$$

where we employed the relation (2.28). The state corresponding to the normal ordered product of two energy–momentum tensors can be determined as follows. From the Laurent expansion

$$N(TT) = \sum_{n \in \mathbb{Z}} z^{-n-4} N(TT)_n,$$

we see that only the mode with $n = -4$ gives a well-defined contribution in the limit $z \rightarrow 0$. But from the general expression for the normal ordered product (2.67), we obtain

$$N(TT)_n = \sum_{k > -2} L_{n-k} L_k + \sum_{k \leq -2} L_k L_{n-k},$$

where the first sum vanishes when applied to $|0\rangle$ and the second sum acting on the vacuum only contributes for $n - k \leq -2$. Taking into account that $n = -4$ from above, we find

$$N(TT)_{-4} |0\rangle = L_{-2} L_{-2} |0\rangle \quad \text{and} \quad N(TT) \longleftrightarrow L_{-2} L_{-2} |0\rangle.$$

Finally, we note that using Eq. (2.69), one can similarly show $N(T\partial T) \leftrightarrow L_{-3} L_{-2} |0\rangle$. These examples motivate the following statement:

For each state $|\Phi\rangle$ in the so-called *Verma module*

$$\{ L_{k_1} \dots L_{k_n} |0\rangle : k_i \leq -2 \},$$

we can find a field $F \in \{T, \partial T, \dots, N(\dots)\}$ with the property that $\lim_{z \rightarrow 0} F(z) |0\rangle = |\Phi\rangle$.

Conformal Family

Let us consider now a general (chiral) primary field $\phi(z)$ of conformal dimension h . This field gives rise to the state $|\phi\rangle = |h\rangle = \phi_{-h} |0\rangle$ which, due to the definition of a primary field (2.45), satisfies

$$L_n |\phi\rangle = [L_n, \phi_{-h}] |0\rangle = (h(n+1) - n) \phi_{-h+n} |0\rangle = 0, \quad (2.73)$$

for $n > 0$. Without providing detailed computations, we note that the modes of the energy–momentum tensor with $n < 0$ acting on a state $|h\rangle$ correspond to the following fields:

Field	State	Level	
$\phi(z)$	$\phi_{-h} 0\rangle = h\rangle$	0	
$\partial\phi$	$L_{-1}\phi_{-h} 0\rangle$	1	
$\partial^2\phi$	$L_{-1}L_{-1}\phi_{-h} 0\rangle$	2	
$N(T\phi)$	$L_{-2}\phi_{-h} 0\rangle$	2	(2.74)
$\partial^3\phi$	$L_{-1}L_{-1}L_{-1}\phi_{-h} 0\rangle$	3	
$N(T\partial\phi)$	$L_{-2}L_{-1}\phi_{-h} 0\rangle$	3	
$N(\partial T\phi)$	$L_{-3}\phi_{-h} 0\rangle$	3	
...	

The lowest lying state in such a tower of states, that is $|h\rangle$, is called a highest weight state. From Eq. (2.74), we conclude furthermore that

Each primary field $\phi(z)$ gives rise to an infinite set of *descendant fields* by taking derivatives ∂^k and taking normal ordered products with T . The set of fields

$$[\phi(z)] := \left\{ \phi, \partial\phi, \partial^2\phi, \dots, N(T\phi), \dots \right\}$$

is called a *conformal family* which is also denoted by $\{\hat{L}_{k_1} \dots \hat{L}_{k_n} \phi(z) : k_i \leq -1\}$.

Remarks

- Referring to the table in Eq. (2.74), note that there are $P(n)$ different states at level n where $P(n)$ is the number of partitions of n . The generating function for $P(n)$ will be important later and reads

$$\prod_{n=1}^{\infty} \frac{1}{1 - q^n} = \sum_{N=0}^{\infty} P(N) q^N .$$

- For unitary theories, we know that the norm of all states has to be non-negative. In particular, recalling Eq. (2.56), for the structure constant of a two-point function this implies $d_{\phi\phi} \geq 0$, where ϕ is a primary field. Let us then consider the norm of the state $L_{-1}|\phi\rangle$ for which we compute

$$\| |L_{-1}|\phi\rangle \|^2 = \langle \phi | L_{+1} L_{-1} | \phi \rangle = \langle \phi | [L_{+1}, L_{-1}] | \phi \rangle = \langle \phi | 2L_0 | \phi \rangle = 2h d_{\phi\phi},$$

where we employed Eq. (2.73) as well as the Virasoro algebra (2.16). In order for this state to have non-negative norm, we see that $h \geq 0$. Therefore, a necessary condition for a theory to be unitary is that the conformal weights of all primary fields are non-negative.

2.9 Simple Examples of CFTs

So far, we have outlined part of the generic structure of conformal field theories without any reference to a Lagrangian formulation. In particular, we introduced CFTs via OPEs, respectively, operator algebras which, as we will see later, is extremely powerful for studying CFTs and in certain cases leads to a complete solution of the dynamics. However, to make contact with the usual approach to quantum field theories and because they naturally appear in string theory, let us consider three simple examples of conformal field theories given in terms of a Lagrangian action.

2.9.1 The Free Boson

Motivation

Let us start with a real massless scalar field $X(x^0, x^1)$ defined on a cylinder given by $x^0 \in \mathbb{R}$ and $x^1 \in \mathbb{R}$ subject to the identification $x^1 \simeq x^1 + 2\pi$. The action for such a theory takes the following form:

$$\begin{aligned} \mathcal{S} &= \frac{1}{4\pi\kappa} \int dx^0 dx^1 \sqrt{|h|} h^{\alpha\beta} \partial_\alpha X \partial_\beta X \\ &= \frac{1}{4\pi\kappa} \int dx^0 dx^1 \left((\partial_{x^0} X)^2 + (\partial_{x^1} X)^2 \right) \end{aligned} \quad (2.75)$$

where $h = \det h_{\alpha\beta}$ with $h_{\alpha\beta} = \text{diag}(+1, +1)$, and κ is some normalisation constant. This is the (Euclideanised) world-sheet action (in conformal gauge) of a string moving in a flat background with coordinate X . Since in this theory there is no mass term setting a scale, we expect this action to be conformally invariant.

In order to study the action (2.75) in more detail, as we have seen in Sect. 2.4, it is convenient to map the cylinder to the complex plane which is achieved by

$$z = e^{x^0} \cdot e^{ix^1}. \quad (2.76)$$

Performing this change of variables for the action (2.75) and denoting the new fields by $X(z, \bar{z})$, we find

$$\mathcal{S} = \frac{1}{4\pi\kappa} \int dz d\bar{z} \sqrt{|g|} g^{ab} \partial_a X \partial_b X \quad (2.77)$$

$$= \frac{1}{4\pi\kappa} \int dz d\bar{z} \partial X \cdot \bar{\partial} X \quad (2.78)$$

with a, b standing for z and \bar{z} . Note that here and in the following we will use the notation $\partial = \partial_z$ and $\bar{\partial} = \partial_{\bar{z}}$ interchangeably. Furthermore, in going from Eq. (2.77) to Eq. (2.78), we employed the explicit form of the metric g_{ab} which we obtained via $g_{ab} = \frac{\partial x^\alpha}{\partial x^a} \frac{\partial x^\beta}{\partial x^b} h_{\alpha\beta}$ and which reads

$$g_{ab} = \begin{bmatrix} 0 & \frac{1}{2z\bar{z}} \\ \frac{1}{2z\bar{z}} & 0 \end{bmatrix}, \quad g^{ab} = \begin{bmatrix} 0 & 2z\bar{z} \\ 2z\bar{z} & 0 \end{bmatrix}.$$

Basic Properties

In the last paragraph, we have provided a connection between the string theory naturally defined on a cylinder and the example of the free boson defined on the complex plane. From a conformal field theory point of view, however, we do not need this discussion but can simply start from the action (2.78)

$$\mathcal{S} = \frac{1}{4\pi\kappa} \int dz d\bar{z} \partial X \cdot \bar{\partial} X \quad (2.79)$$

The equation of motion for this action is derived by varying \mathcal{S} with respect to X . We thus calculate

$$\begin{aligned} 0 &= \delta_X \mathcal{S} \\ &= \frac{1}{4\pi\kappa} \int dz d\bar{z} \left(\partial \delta X \cdot \bar{\partial} X + \partial X \cdot \bar{\partial} \delta X \right) \\ &= \frac{1}{4\pi\kappa} \int dz d\bar{z} \left(\partial \left(\delta X \cdot \bar{\partial} X \right) - \delta X \cdot \partial \bar{\partial} X + \bar{\partial} \left(\partial X \cdot \delta X \right) - \bar{\partial} \partial X \cdot \delta X \right) \\ &= -\frac{1}{2\pi\kappa} \int dz d\bar{z} \delta X \left(\partial \bar{\partial} X \right) \end{aligned}$$

which has to be satisfied for all variations δX . Therefore, we obtain the equation of motion as

$$\partial \bar{\partial} X(z, \bar{z}) = 0,$$

from which we conclude that

$$\begin{aligned} j(z) &= i \partial X(z, \bar{z}) && \text{is a chiral field,} \\ \bar{j}(\bar{z}) &= i \bar{\partial} X(z, \bar{z}) && \text{is an anti-chiral field.} \end{aligned} \quad (2.80)$$

Next, we are going to determine the conformal properties of the fields in the action (2.79). In particular, this action is invariant under conformal transformations if the field $X(z, \bar{z})$ has vanishing conformal dimensions, that is, $X'(z, \bar{z}) = X(w, \bar{w})$. Let us then compute

$$\begin{aligned} \mathcal{S} &\longrightarrow \frac{1}{4\pi\kappa} \int dz d\bar{z} \partial_z X'(z, \bar{z}) \cdot \partial_{\bar{z}} X'(z, \bar{z}) \\ &= \frac{1}{4\pi\kappa} \int \frac{\partial z}{\partial w} dw \frac{\partial \bar{z}}{\partial \bar{w}} d\bar{w} \frac{\partial w}{\partial z} \partial_w X(w, \bar{w}) \cdot \frac{\partial \bar{w}}{\partial \bar{z}} \partial_{\bar{w}} X(w, \bar{w}) \\ &= \frac{1}{4\pi\kappa} \int dw d\bar{w} \partial_w X(w, \bar{w}) \cdot \partial_{\bar{w}} X(w, \bar{w}) \end{aligned}$$

which indeed shows the invariance of the action (2.79) under conformal transformations if $X(z, \bar{z})$ has conformal dimensions $(h, \bar{h}) = (0, 0)$. Moreover, by considering again the calculation above, we can conclude that the fields (2.80) are primary with dimensions $(h, \bar{h}) = (1, 0)$ and $(h, \bar{h}) = (0, 1)$ respectively. Finally, because we are considering a free theory, the engineering dimensions of the fields argued for above is the same as the dimension after quantisation.

Two-Point Function and Laurent Mode Algebra

Let us proceed and determine the propagator $K(z, \bar{z}, w, \bar{w}) = \langle X(z, \bar{z}) X(w, \bar{w}) \rangle$ of the free boson $X(z, \bar{z})$ from the action (2.79). To do so, we note that $K(z, \bar{z}, w, \bar{w})$ in the present case has to satisfy

$$\partial_z \partial_{\bar{z}} K(z, \bar{z}, w, \bar{w}) = -2\pi\kappa \delta^{(2)}(z - w).$$

Using the representation of the δ -function $2\pi \delta^{(2)} = \partial_z \bar{z}^{-1}$, one can then check that the following expression is a solution to this equation:

$$K(z, \bar{z}, w, \bar{w}) = \langle X(z, \bar{z}) X(w, \bar{w}) \rangle = -\kappa \log |z - w|^2, \quad (2.81)$$

which gives the result for the two-point function of $X(z, \bar{z})$. In particular, by comparing with Eq. (2.49), we see again that the free boson itself is not a quasi-primary field. However, from the propagator above we can deduce the two-point function of say two chiral fields $j(z)$ by applying derivatives ∂_z and ∂_w to Eq. (2.81)

$$\begin{aligned} -\langle \partial_z X(z, \bar{z}) \partial_w X(w, \bar{w}) \rangle &= -\kappa \partial_z \partial_w \left(-\log(z - w) - \log(\bar{z} - \bar{w}) \right) \\ \langle j(z) j(w) \rangle &= \frac{\kappa}{(z - w)^2}, \end{aligned} \quad (2.82)$$

and along similar lines we obtain the result in the anti-chiral sector as well as $\langle j(z) \bar{j}(\bar{w}) \rangle = 0$. We can then summarise that the normalisation constant of the two-point function is $d_{jj} = \kappa$.

Let us finally recall our discussion on p. 37 about current algebras and determine the algebra of the Laurent modes of $j(z)$. Since we only have one such (chiral) current in our theory, the anti-symmetry of $C_{ij}^k = -C_{ji}^k$ implies $C_{jj}^j = 0$ which leads us to

$$\boxed{[j_m, j_n] = \kappa m \delta_{m+n,0}} . \quad (2.83)$$

The Energy–Momentum Tensor

We will now turn to the energy–momentum tensor for the theory of the free boson. Since we have an action for our theory, we can actually derive this quantity. We define the energy–momentum tensor for the action (2.77) in the following way:

$$T_{ab} = 4\pi\kappa\gamma \frac{1}{\sqrt{|g|}} \frac{\delta \mathcal{S}}{\delta g^{ab}} , \quad (2.84)$$

where we have allowed for a to be determined normalisation constant γ and a, b stand for z and \bar{z} respectively. Performing the variation of the action (2.77) using

$$\delta \sqrt{|g|} = -\frac{1}{2} \sqrt{|g|} g_{ab} \delta g^{ab} ,$$

we find the following result:

$$T_{zz} = \gamma \partial X \partial X , \quad T_{z\bar{z}} = T_{\bar{z}z} = 0 , \quad T_{\bar{z}\bar{z}} = \gamma \bar{\partial} X \bar{\partial} X .$$

However, for a quantum theory we want the expectation value of the energy–momentum tensor to vanish and so we take the normal ordered expression. Focussing only on the chiral part, this reads

$$T(z) = \gamma N(\partial X \partial X)(z) = \gamma N(jj)(z) .$$

The constant γ can be fixed via the requirement that $j(z)$ is a primary field of conformal dimension $h = 1$ with respect to $T(z)$. To do so, we expand the energy–momentum tensor as $T(z) = \sum_{n \in \mathbb{Z}} z^{-n-2} L_n$ and find for the Laurent modes

$$L_n = \gamma N(jj)_n = \gamma \sum_{k > -1} j_{n-k} j_k + \gamma \sum_{k \leq -1} j_k j_{n-k} , \quad (2.85)$$

where we used the expression for normal ordered products derived in Sect. 2.7. Recalling the Laurent expansion (2.84) of $j(z)$, we can compute the following commutator:

$$\begin{aligned}
[L_m, j_n] &= \gamma [N(jj)_m, j_n] \\
&= \gamma \sum_{k>-1} (j_{m-k}[j_k, j_n] + [j_{m-k}, j_n]j_k) \\
&\quad + \gamma \sum_{k\leq-1} (j_k[j_{m-k}, j_n] + [j_k, j_n]j_{m-k}) \\
&= \gamma \kappa \left(\sum_{k>-1} j_{m-k} k \delta_{k,-n} + (m-k) \delta_{m-k,-n} j_k \right. \\
&\quad \left. + \sum_{k\leq-1} j_k (m-k) \delta_{m-k,-n} + k \delta_{k,-n} j_{m-k} \right) \\
&= -2\gamma\kappa n j_{m+n} ,
\end{aligned}$$

where we employed Eq. (2.83). If we compare this expression with Eq. (2.45), we see that for $2\gamma\kappa = 1$ this is the commutator of L_m with a primary field of conformal dimension $h = 1$. Therefore, we can conclude that the energy–momentum tensor reads

$$T(z) = \frac{1}{2\kappa} N(jj)(z) . \quad (2.86)$$

The Central Charge

After having determined the energy–momentum tensor $T(z)$ up to a constant, we can now ask what is the central charge of the free boson conformal field theory. To determine c we employ the Virasoro algebra to compute

$$\langle 0|L_{+2}L_{-2}|0\rangle = \langle 0|[L_2, L_{-2}]|0\rangle = \frac{c}{2} , \quad (2.87)$$

where we used that $L_n|0\rangle = 0$ for $n > -2$. Next, we recall $L_{\mp 2} = \frac{1}{2\kappa} N(jj)_{\mp 2}$ from which we find

$$L_{-2}|0\rangle = \frac{1}{2\kappa} j_{-1}j_{-1}|0\rangle , \quad \langle 0|L_{+2} = \frac{1}{2\kappa} \langle 0|(j_2j_0 + j_1j_1) = \frac{1}{2\kappa} \langle 0|j_1j_1 ,$$

where we used that $\langle 0|j_2j_0 = -\langle 0|j_0j_2 = 0$. Employing these expressions in Eq. (2.87), we obtain

$$\begin{aligned}
\frac{c}{2} &= \frac{1}{4\kappa^2} \langle 0 | j_1 j_1 j_{-1} j_{-1} | 0 \rangle \\
&= \frac{1}{4\kappa^2} \left(\langle 0 | j_1 j_{-1} j_1 j_{-1} | 0 \rangle + \langle 0 | j_1 \underbrace{[j_1, j_{-1}]} j_{-1} | 0 \rangle \right) \\
&= \frac{1}{4\kappa^2} \left(\langle 0 | [j_1, j_{-1}] [j_1, j_{-1}] | 0 \rangle + \kappa \langle 0 | [j_1, j_{-1}] | 0 \rangle \right) \\
&= \frac{1}{4\kappa^2} 2\kappa^2 = \frac{1}{2}
\end{aligned}$$

where we employed $[j_1, j_{-1}] = \kappa$ as well as that $j_k | 0 \rangle = 0$ for $k > -1$ and that $\langle 0 | j_k = 0$ for $k < 1$. We have therefore shown

The conformal field theory of a free boson has central charge $c = 1$.

Remarks

- Let us make contact with our discussion in Sect. 2.6.3 and compare our results to Eq. (2.58). First, by recalling equation (2.56) we obtain from Eq. (2.87) that $d_{LL} = \frac{c}{2}$. Second, with the help of Eq. (2.57) we can determine C_{LLL} as follows:

$$C_{LLL} = \langle 0 | L_2 L_0 L_{-2} | 0 \rangle = \langle 0 | L_2 [L_0, L_{-2}] | 0 \rangle = 2 \langle 0 | L_2 L_{-2} | 0 \rangle = 2 \frac{c}{2} = c$$

where we also employed Eq. (2.87). Finally, referring to p. 34, we use $C_{ij}^k = C_{ijl} (d_{lk})^{-1}$ to find $C_{LL}^L = 2$ which is in agreement with Eq. (2.58). Therefore, as expected, the Laurent modes of the energy–momentum tensor (2.86) of the free boson satisfy the Virasoro algebra.

- Note that on p. 16, we have chosen the normalisation of the central extension $p(2, -2)$ in such a way that we obtain $c = 1$ for the free boson.
- Usually, one chooses the normalisation constant κ to be $\kappa = 1$ in order to simplify various expressions such as

$$\langle j(z) j(w) \rangle = \frac{1}{(z-w)^2} \quad \text{and} \quad T(z) = \frac{1}{2} N(jj)(z). \quad (2.88)$$

Centre of Mass Position and Momentum

Let us come back to the chiral and anti-chiral currents from Eq. (2.80) and recall once more their Laurent expansion

$$j(z) = i \partial X(z) = \sum_{n \in \mathbb{Z}} j_n z^{-n-1}, \quad \bar{j}(\bar{z}) = i \bar{\partial} X(\bar{z}) = \sum_{n \in \mathbb{Z}} \bar{j}_n z^{-n-1},$$

which we can integrate to find

$$X(z, \bar{z}) = x_0 - i \left(j_0 \ln z + \bar{j}_0 \ln \bar{z} \right) + i \sum_{n \neq 0} \frac{1}{n} \left(j_n z^{-n} + \bar{j}_n \bar{z}^{-n} \right). \quad (2.89)$$

If we identify \bar{z} with the complex conjugate z^* of z , then the field X is defined on the complex plane. As such, it has to be invariant under rotations $z \mapsto e^{2\pi i} z$ which, referring to Eq. (2.89), implies that

$$j_0 = \bar{j}_0. \quad (2.90)$$

However, as we will see in Sect. 4.2.2, for the free boson $X(z, \bar{z})$ compactified on a circle, this relation will be modified.

Let us furthermore recall from the beginning of this section that the example of the free boson can be related to string theory. In particular, using the mapping (2.76), we can express Eq. (2.89) in terms of coordinates x^0 and x^1 on the cylinder

$$X(x^0, x^1) = x_0 - i (j_0 + \bar{j}_0) x^0 + (j_0 - \bar{j}_0) x^1 + i \sum_{n \neq 0} \frac{1}{n} \left(j_n e^{-n(x^0 + ix^1)} + \bar{j}_n e^{-n(x^0 - ix^1)} \right).$$

Computing the centre of mass momentum π_0 of a string, we obtain

$$\pi_0 = \frac{1}{4\pi} \int_0^{2\pi} dx^1 \frac{\partial X(x^0, x^1)}{\partial(-ix^0)} = \frac{j_0 + \bar{j}_0}{2} = j_0, \quad (2.91)$$

where the additional factor of $(-i)$ is due to the fact that we are working with Euclidean signature. Similarly, the following expression

$$\frac{1}{2\pi} \int_0^{2\pi} dx^1 X(x^0 = 0, x^1) = x_0$$

shows that x_0 is the centre of mass coordinate of a string. Performing then the usual quantisation, not only j_n and \bar{j}_n are promoted to operators but also x_0 . Since x_0 and π_0 are the position, and momentum operator, respectively, we naturally impose the commutation relation

$$[x_0, \pi_0] = i. \quad (2.92)$$

Vertex Operator

As we have mentioned earlier, the free boson $X(z, \bar{z})$ is not a conformal field since its conformal dimensions vanish $(h, \bar{h}) = (0, 0)$. However, using $X(z, \bar{z})$ we can define the so-called vertex operators which have non-vanishing conformal weights.

The vertex operator $V(z, \bar{z}) =: e^{i\alpha X(z, \bar{z})} :$ is a primary field of conformal dimension $(h, \bar{h}) = (\frac{\alpha^2}{2}, \frac{\alpha^2}{2})$ with respect to the energy–momentum tensors $T(z) = \frac{1}{2}N(jj)(z)$ and $\bar{T}(\bar{z}) = \frac{1}{2}N(\bar{j}\bar{j})(\bar{z})$.

Here we have used the notation $: \dots :$ to denote the normal ordering which is also common in the literature. In the following, we will verify that this vertex operator has indeed the conformal dimensions stated above.

To do so, we start by making the expression for the vertex operator more concrete using Eq. (2.89). Keeping in mind that j_n for $n > -1$ are annihilation operators, we can perform the normal ordering to obtain

$$V(z, \bar{z}) = \exp\left(i\alpha x_0 - \alpha \sum_{n \leq -1} \frac{j_n}{n} z^{-n}\right) \cdot \exp\left(\alpha \pi_0 \ln z - \alpha \sum_{n \geq 1} \frac{j_n}{n} z^{-n}\right) \cdot \bar{v}(\bar{z}), \quad (2.93)$$

where for convenience we have put all the anti-holomorphic dependence into $\bar{v}(\bar{z})$. Next, let us compute the j_0 eigenvalue of this vertex operator which we can infer from $[j_0, V]$. Because of $[j_m, j_n] = m \delta_{m, -n}$, we see that j_0 commutes with all j_n and so we only need to evaluate

$$\begin{aligned} [j_0, e^{i\alpha x_0}] &= \sum_{k=0}^{\infty} \frac{(i\alpha)^k}{k!} \underbrace{[j_0, x_0^k]}_{= k(-i)x_0^{k-1}} = - \sum_{k=1}^{\infty} \frac{i(i\alpha)^k}{(k-1)!} x_0^{k-1} = -i(i\alpha) e^{i\alpha x_0}, \end{aligned} \quad (2.94)$$

where we employed Eq. (2.92). We therefore find that $[j_0, V] = \alpha V$. Recalling then our definition Eq. (2.28) of an asymptotic state and computing

$$j_0 |\alpha\rangle = \lim_{z, \bar{z} \rightarrow 0} [j_0, V_\alpha(z, \bar{z})] |0\rangle = \lim_{z, \bar{z} \rightarrow 0} \alpha V(z, \bar{z}) |0\rangle = \alpha |\alpha\rangle,$$

we see that the j_0 eigenvalue of the vertex operator (2.93) is α .

Now, we are going to determine the conformal dimension of the vertex operator (2.93) by computing the commutator $[L_0, V]$. To do so, let us first recall from Eq. (2.88) the explicit form of L_0

$$L_0 = \frac{1}{2} j_0 j_0 + \frac{1}{2} \sum_{k \geq 1} j_{-k} j_k + \frac{1}{2} \sum_{k \leq -1} j_k j_{-k}.$$

Next, we note again that only j_0 has non-trivial commutation relations with x_0 so we find for the first factor in Eq. (2.93)

$$[L_0, e^{i\alpha x_0}] = \frac{1}{2} [j_0 j_0, e^{i\alpha x_0}] = \frac{\alpha}{2} (j_0 e^{i\alpha x_0} + e^{i\alpha x_0} j_0). \quad (2.95)$$

For the terms in Eq. (2.93) involving the modes j_n with $n \neq 0$, let us define

$$J^- = - \sum_{n \leq -1} \frac{j_n}{n} z^{-n}, \quad J^+ = - \sum_{n \geq 1} \frac{j_n}{n} z^{-n},$$

for which we calculate using $[L_0, j_n] = -n j_n$

$$[L_0, J^-] = \sum_{n \leq -1} j_n z^{-n} = z \partial_z J^-, \quad [L_0, J^+] = z \partial_z J^+.$$

Performing then the series expansion of the exponential and employing our findings from above, we can evaluate

$$\begin{aligned} [L_0, e^{\alpha J^-}] &= \sum_{k=0}^{\infty} \frac{\alpha^k}{k!} [L_0, (J^-)^k] = \sum_{k=0}^{\infty} \frac{\alpha^k}{k!} k z (\partial J^-) (J^-)^{k-1} \\ &= \sum_{k=0}^{\infty} \frac{\alpha^k}{k!} z \partial \left((J^-)^k \right) = z \partial (e^{\alpha J^-}), \end{aligned}$$

and we find a similar result for J^+ . Observing finally that $[L_0, \bar{v}(\bar{z})] = 0$, we are now in the position to calculate the full commutator of L_0 and $V(z, \bar{z})$ to determine the conformal dimension of $V(z, \bar{z})$

$$\begin{aligned} [L_0, V(z, \bar{z})] &= [L_0, e^{i\alpha x_0}] e^{\alpha J^-} z^{\alpha\pi_0} e^{\alpha J^+} \bar{v} + e^{i\alpha x_0} [L_0, e^{\alpha J^-}] z^{\alpha\pi_0} e^{\alpha J^+} \bar{v} \\ &\quad + e^{i\alpha x_0} e^{\alpha J^-} [L_0, z^{\alpha\pi_0}] e^{\alpha J^+} \bar{v} + e^{i\alpha x_0} e^{\alpha J^-} z^{\alpha\pi_0} [L_0, e^{\alpha J^+}] \bar{v} \\ &= \frac{\alpha}{2} (j_0 e^{i\alpha x_0} + e^{i\alpha x_0} j_0) e^{\alpha J^-} z^{\alpha\pi_0} e^{\alpha J^+} \bar{v} + e^{i\alpha x_0} (z \partial_z e^{\alpha J^-}) z^{\alpha\pi_0} e^{\alpha J^+} \bar{v} \\ &\quad + 0 + e^{i\alpha x_0} e^{\alpha J^-} z^{\alpha\pi_0} (z \partial_z e^{\alpha J^+}) \bar{v} \\ &= \frac{\alpha}{2} (j_0 e^{i\alpha x_0} + e^{i\alpha x_0} j_0) e^{\alpha J^-} z^{\alpha\pi_0} e^{\alpha J^+} \bar{v} + z \partial V(z, \bar{z}) \\ &\quad - e^{i\alpha x_0} e^{\alpha J^-} (z \partial_z z^{\alpha\pi_0}) e^{\alpha J^+} \bar{v} \\ &= \frac{\alpha}{2} (j_0 e^{i\alpha x_0} + e^{i\alpha x_0} j_0) e^{\alpha J^-} z^{\alpha\pi_0} e^{\alpha J^+} \bar{v} + z \partial V(z, \bar{z}) \\ &\quad - \alpha e^{i\alpha x_0} j_0 e^{\alpha J^-} z^{\alpha\pi_0} e^{\alpha J^+} \bar{v} \\ &= \frac{\alpha}{2} [j_0, e^{i\alpha x_0}] e^{\alpha J^-} z^{\alpha\pi_0} e^{\alpha J^+} \bar{v} + z \partial V(z, \bar{z}) \\ &= \frac{\alpha^2}{2} V(z, \bar{z}) + z \partial V(z, \bar{z}) \end{aligned}$$

where we used Eqs. (2.94) and (2.95). Let us then again recall our definition (2.28) of an asymptotic state in terms of an operator and compute

$$\begin{aligned} L_0 |\alpha\rangle &= \lim_{z, \bar{z} \rightarrow 0} [L_0, V_\alpha(z, \bar{z})] |0\rangle = \lim_{z, \bar{z} \rightarrow 0} \left(\frac{\alpha^2}{2} V(z, \bar{z}) + z \partial V(z, \bar{z}) \right) |0\rangle \\ &= \frac{\alpha^2}{2} \lim_{z, \bar{z} \rightarrow 0} V(z, \bar{z}) |0\rangle = \frac{\alpha^2}{2} |\alpha\rangle. \end{aligned}$$

The conformal weight of a vertex operator $V_\alpha(z, \bar{z})$ therefore is $h = \frac{\alpha^2}{2}$, and a similar result is obtained in the anti-chiral sector. This verifies our statement from the beginning of this paragraph regarding the conformal weights of the vertex operator. In order to show that $V(z, \bar{z})$ is a primary field, one can compute along similar lines the commutator $[L_m, V(z, \bar{z})] |0\rangle$ and compare with the definition of a primary field given in Eq. (2.45).

Next, let us note that the action of a free boson (2.79) is invariant under transformations $X(z, \bar{z}) \mapsto X(z, \bar{z}) + a$ where a is an arbitrary constant. In order for the correlator of two vertex operators $\langle V_\alpha V_\beta \rangle$ to respect this symmetry, we infer from the definition $V_\alpha = :e^{i\alpha X}$: the condition $\alpha + \beta = 0$. Recalling then our discussion in Sect. 2.6.2 and keeping in mind that $V_\alpha(z, \bar{z})$ is a primary field, for the two-point function of two vertex operators we find

$$\langle V_{-\alpha}(z, \bar{z}) V_\alpha(w, \bar{w}) \rangle = \frac{1}{(z-w)^{\alpha^2} (\bar{z}-\bar{w})^{\alpha^2}}.$$

Here we have included the result for the anti-holomorphic sector, which can be obtained in a similar fashion as the holomorphic part. However, we will study non-holomorphic OPEs in much more detail in Sect. 2.12. Since $\alpha + \beta = 0$, for the two-point function of vertex operators with equal j_0 eigenvalues, we have

$$\langle V_{+\alpha} V_{+\alpha} \rangle = \langle V_{-\alpha} V_{-\alpha} \rangle = 0.$$

Let us also mention that the current $j(z) = i\partial X(z, \bar{z})$ is conserved and that the conserved charge is $Q = \oint \frac{dz}{2\pi i} j(z) = j_0$. We can thus interpret α as the charge of an vertex operator $V_\alpha(z, \bar{z})$ and the requirement $\alpha + \beta = 0$ as charge conservation.

In passing, we note that vertex operators play a very important role in string theory, where the charge α is interpreted as the space–time momentum along the space–time direction X . The condition of charge conservation then corresponds to momentum conservation in space–time.

Current Algebra

After having verified the conformal dimension of the vertex operator $V_\alpha = :e^{i\alpha X}$: to be $(h, \bar{h}) = (\frac{\alpha^2}{2}, \frac{\alpha^2}{2})$, let us now turn to the special case $\alpha = \pm\sqrt{2}$ for which $V_{\pm\sqrt{2}}(z, \bar{z})$ has conformal dimension $(h, \bar{h}) = (1, 1)$. Therefore, following our definition from p. 37, these fields are currents. In order to simplify our discussion in this paragraph, let us focus only on the holomorphic part of the vertex operator (including the position operator x_0) which we write as

$$j^\pm(z) = : e^{\pm i\sqrt{2}X} : ,$$

and study the current algebra of $j^\pm(z)$ and $j(z) = i(\partial X)(z)$. On p. 37, we have given the general form of a current algebra of quasi-primary fields which we recall for convenience

$$[j_{(i)m}, j_{(j)n}] = \sum_k C_{ij}^k j_{(k)m+n} + d_{ij} m \delta_{m,-n} , \quad C_{ij}^k = -C_{ji}^k .$$

Let us then determine the normalisation constants of the two-point function d_{ij} . By the argument that the overall j_0 charge in a correlation function should vanish, we see that

$$d_{jj} = d_{+-} = d_{-+} = 1 , \quad d_{j\pm} = d_{\pm j} = 0 ,$$

where we use subscripts \pm for $j^\pm(z)$ and employed the usual normalisation. Next, using Eq. (2.57) as well as relations (2.26) and (2.28), we can compute

$$\begin{aligned} C_{+j-} &= \langle 0 | j_1^+ j_0 j_{-1}^- | 0 \rangle = \lim_{z \rightarrow 0} \langle 0 | j_1^+ j_0 V_{-\sqrt{2}}(z) | 0 \rangle \\ &= -\sqrt{2} \langle 0 | j_1^+ j_{-1}^- | 0 \rangle \\ &= -\sqrt{2} d_{+-} = -\sqrt{2} , \end{aligned}$$

and a similar computation leads to $C_{-j+} = +\sqrt{2}$. Noting that also for the three-point function the overall j_0 charge has to vanish and using the relation $C_{ijk} = C_{ij}^l d_{lk}$ together with the anti-symmetry of C_{ij}^k , we can determine the non-vanishing structure constants to be

$$C_{j+}^+ = -C_{+j}^+ = +\sqrt{2} , \quad C_{j-}^- = -C_{-j}^- = -\sqrt{2} , \quad C_{+-}^j = -C_{-+}^j .$$

The only unknown constant C_{+-}^j can be fixed using the relation $C_{ijk} = C_{ij}^l d_{lk}$ from p. 34 in the following way:

$$C_{+-}^j = C_{+-j} d^{jj} = C_{-j}^- d_{-+} d^{jj} = \sqrt{2} \cdot 1 \cdot \frac{1}{1} = \sqrt{2} .$$

Combining all these results, we can finally write down the current algebra of $j^\pm(z)$ and $j(z)$ which reads

$$\begin{aligned} [j_m, j_n] &= m \delta_{m+n,0} , & [j_m^\pm, j_n^\pm] &= 0 , \\ [j_m, j_n^\pm] &= \pm\sqrt{2} j_{m+n}^\pm , & [j_m^+, j_n^-] &= \sqrt{2} j_{m+n} + m \delta_{m+n,0} . \end{aligned} \tag{2.96}$$

However, in order to highlight the underlying structure, let us make the following definitions:

$$j^1 = \frac{1}{\sqrt{2}} (j^+ + j^-), \quad j^2 = \frac{1}{\sqrt{2}i} (j^+ - j^-), \quad j^3 = j.$$

The commutation relations for the Laurent modes of the new currents are determined using the relations in Eq. (2.96). We calculate for instance

$$\begin{aligned} [j_m^1, j_n^2] &= \frac{1}{2i} \left(-[j_m^+, j_n^-] + [j_m^-, j_n^+] \right) = \frac{1}{2i} (-2\sqrt{2} j_{m+n}) = +i\sqrt{2} j_{m+n}^3, \\ [j_m^3, j_n^1] &= \frac{1}{\sqrt{2}} [j_m^3, j_n^+ + j_n^-] = \frac{1}{\sqrt{2}} (\sqrt{2} j_{m+n}^+ - \sqrt{2} j_{m+n}^-) = +i\sqrt{2} j_{m+n}^2, \\ [j_m^1, j_n^1] &= \frac{1}{2} \left([j_m^+, j_n^-] + [j_m^-, j_n^+] \right) = \frac{1}{2} (m - n) \delta_{m+n,0} = m \delta_{m+n,0}, \end{aligned}$$

from which we infer the general expression

$$\boxed{[j_m^i, j_n^j] = +i\sqrt{2} \sum_k \epsilon^{ijk} j_{m+n}^k + m \delta^{ij} \delta_{m,-n}}$$

where ϵ^{ijk} is the totally anti-symmetric tensor. These commutation relations define the $\mathfrak{su}(2)$ Kač–Moody algebra at level $k = 1$, which is usually denoted as $\widehat{\mathfrak{su}}(2)_1$. These algebras are discussed in Chap. 3 in more generality. Furthermore, this current algebra is related to the theory of the free boson X compactified on a radius $R = \frac{1}{\sqrt{2}}$ which we will study in Sect. 4.2.2.

Hilbert Space

Let us note that the Hilbert space of the free boson theory contains for instance the following chiral states:

$$\begin{aligned} \text{level 1 :} & \quad j_{-1} |0\rangle, \\ \text{level 2 :} & \quad j_{-2} |0\rangle, \quad j_{-1} j_{-1} |0\rangle, \\ \text{level 3 :} & \quad j_{-3} |0\rangle, \quad j_{-2} j_{-1} |0\rangle, \quad j_{-1} j_{-1} j_{-1} |0\rangle, \\ & \quad \dots \quad \dots \end{aligned} \tag{2.97}$$

where we have used that $[j_{-m}, j_{-n}] = 0$ for $m, n \geq 0$. Taking also the anti-chiral sector as well as $[j_m, \bar{j}_n] = 0$ into account, we can conclude that the Hilbert space of the free boson theory is

$$\mathcal{H} = \{ \text{Fock space freely generated by } j_{-n}, \bar{j}_{-m} \text{ for } n, m \geq 1 \}.$$

The number of states at each level N is given by the number of partitions $P(N)$ of N whose generating function we have already encountered at the end of Sect. 2.8. The generating function for the degeneration of states at each level N in the chiral sector therefore is

$$\mathcal{Z}(q) = \prod_{n \geq 1} \frac{1}{1 - q^n} = \sum_{N=0}^{\infty} P(N) q^N. \quad (2.98)$$

Combining now the chiral and anti-chiral sectors, we obtain

$$\mathcal{Z}(q, \bar{q}) = \prod_{n \geq 1} \frac{1}{(1 - q^n)(1 - \bar{q}^n)}.$$

In Chap. 4, we will identify such expressions with partition functions of conformal field theories and relate them to modular forms.

2.9.2 The Free Fermion

Motivation

As a second example for a conformal field theory, we will study the action of a free Majorana fermion in two-dimensional Minkowski space with metric $h_{\alpha\beta} = \text{diag}(+1, -1)$

$$S = \frac{1}{4\pi\kappa} \int dx^0 dx^1 \sqrt{|h|} (-i) \bar{\Psi} \gamma^\alpha \partial_\alpha \Psi, \quad (2.99)$$

where κ is a normalisation constant. Here, $\bar{\Psi}$ is defined as $\bar{\Psi} = \Psi^\dagger \gamma^0$ where \dagger denotes hermitian conjugation and the $\{\gamma^\alpha\}$ are two-by-two matrices satisfying the Clifford algebra

$$\gamma^\alpha \gamma^\beta + \gamma^\beta \gamma^\alpha = 2 h^{\alpha\beta} \mathbb{1}_2,$$

with $\mathbb{1}_2$ the two-by-two unit matrix. There are various representations of γ -matrices satisfying this algebra which are, however, equivalent. We make the following choice:

$$\gamma^0 = \begin{pmatrix} 0 & 1 \\ 1 & 0 \end{pmatrix}, \quad \gamma^1 = \begin{pmatrix} 0 & 1 \\ -1 & 0 \end{pmatrix},$$

for which the Majorana condition becomes that the components $\psi, \bar{\psi}$ of the spinor Ψ are real. We then perform a Wick rotation $x_1 \rightarrow ix_1$ under which the partial derivative transforms as $\partial_1 \rightarrow -i\partial_1$. Effectively, the Wick rotation means choosing the γ -matrices

$$\gamma^0 = \begin{pmatrix} 0 & 1 \\ 1 & 0 \end{pmatrix}, \quad \gamma^1 = \begin{pmatrix} 0 & -i \\ i & 0 \end{pmatrix},$$

and we furthermore note that the Wick rotation introduces an additional factor of i for Eq. (2.99). We can simplify the action (2.99) by observing

$$\gamma^0 \gamma^\mu \partial_\mu = \gamma^0 (\gamma^0 \partial_0 + \gamma^1 \partial_1) = \begin{pmatrix} \partial_0 + i \partial_1 & 0 \\ 0 & \partial_0 - i \partial_1 \end{pmatrix} = 2 \begin{pmatrix} \partial_{\bar{z}} & 0 \\ 0 & \partial_z \end{pmatrix},$$

where we have defined $z = x^0 + ix^1$. As we have seen before, it is convenient to work with fields depending on complex variables and so we write the Majorana spinors as

$$\Psi = \begin{pmatrix} \psi(z, \bar{z}) \\ \bar{\psi}(z, \bar{z}) \end{pmatrix}.$$

Note that $\psi(z, \bar{z})$ and $\bar{\psi}(z, \bar{z})$ are still real fields, in particular $\psi^\dagger = \psi$ and $\bar{\psi}^\dagger = \bar{\psi}$. Employing then the various arguments above, we can write the action (2.99) after a Wick rotation in the following way:

$$\begin{aligned} \mathcal{S} &= \frac{1}{4\pi\kappa} \int dz d\bar{z} \sqrt{|g|} 2 \Psi^\dagger \begin{pmatrix} \partial_{\bar{z}} & 0 \\ 0 & \partial_z \end{pmatrix} \Psi \\ &= \frac{1}{4\pi\kappa} \int dz d\bar{z} (\psi \bar{\partial} \psi + \bar{\psi} \partial \bar{\psi}) \end{aligned} \quad (2.100)$$

where we used that the components of the metric g , obtained from $h_{\alpha\beta}$ via the change of coordinates $z = x^0 + ix^1$, read

$$g_{ab} = \begin{bmatrix} 0 & \frac{1}{2} \\ \frac{1}{2} & 0 \end{bmatrix}, \quad g^{ab} = \begin{bmatrix} 0 & 2 \\ 2 & 0 \end{bmatrix}. \quad (2.101)$$

Basic Properties

From a conformal field theory point of view, we do not necessarily need the derivation above but can simply start from the action (2.100)

$$\boxed{\mathcal{S} = \frac{1}{4\pi\kappa} \int dz d\bar{z} (\psi \bar{\partial} \psi + \bar{\psi} \partial \bar{\psi})}. \quad (2.102)$$

The equations of motion for this theory are obtained by varying the action with respect to the fields ψ and $\bar{\psi}$ which reads

$$\begin{aligned}
0 = \delta_\psi \mathcal{S} &= \frac{1}{4\pi\kappa} \int d^2z \left(\delta\psi \bar{\partial}\psi + \psi \bar{\partial}(\delta\psi) \right) \\
&= \frac{1}{4\pi\kappa} \int d^2z \left(\delta\psi \bar{\partial}\psi + \bar{\partial}(\psi \delta\psi) - (\bar{\partial}\psi) \delta\psi \right) \\
&= \frac{1}{2\pi\kappa} \int d^2z \delta\psi \bar{\partial}\psi
\end{aligned}$$

where we performed a partial integration on the second term and noted that fermionic fields anti-commute. Since the equation above has to be satisfied for all variations $\delta\psi$, we find for the equations of motion

$$\partial\bar{\psi} = \bar{\partial}\psi = 0, \quad (2.103)$$

where we also included the result for the variation with respect to $\delta\bar{\psi}$ obtained along similar lines. We can then conclude that $\psi = \psi(z)$ is a chiral field and $\bar{\psi} = \bar{\psi}(\bar{z})$ is an anti-chiral field.

Next, we will determine the conformal properties of the fields $\psi(z)$ and $\bar{\psi}(\bar{z})$. By performing similar steps as for the example of the free boson, we see that the action (2.102) is invariant under conformal transformations if the fields ψ and $\bar{\psi}$ are primary with conformal dimensions $(h, \bar{h}) = (\frac{1}{2}, 0)$, and $(h, \bar{h}) = (0, \frac{1}{2})$ respectively. Let us verify this observation by computing

$$\begin{aligned}
\mathcal{S} &\longrightarrow \frac{1}{4\pi\kappa} \int dz d\bar{z} \left(\psi'(z, \bar{z}) \partial_{\bar{z}} \psi'(z, \bar{z}) + \bar{\psi}'(z, \bar{z}) \partial_z \bar{\psi}'(z, \bar{z}) \right) \\
&= \frac{1}{4\pi\kappa} \int \frac{\partial z}{\partial w} dw \frac{\partial \bar{z}}{\partial \bar{w}} d\bar{w} \left(\left(\frac{\partial w}{\partial z} \right)^{\frac{1}{2}} \psi(w, \bar{w}) \frac{\partial \bar{w}}{\partial \bar{z}} \partial_{\bar{w}} \left(\frac{\partial w}{\partial z} \right)^{\frac{1}{2}} \psi(w, \bar{w}) \right. \\
&\quad \left. + \left(\frac{\partial \bar{w}}{\partial \bar{z}} \right)^{\frac{1}{2}} \bar{\psi}(w, \bar{w}) \frac{\partial w}{\partial z} \partial_w \left(\frac{\partial \bar{w}}{\partial \bar{z}} \right)^{\frac{1}{2}} \bar{\psi}(w, \bar{w}) \right) \\
&= \frac{1}{4\pi\kappa} \int dw d\bar{w} \left(\psi(w, \bar{w}) \partial_{\bar{w}} \psi(w, \bar{w}) + \bar{\psi}(w, \bar{w}) \partial_w \bar{\psi}(w, \bar{w}) \right)
\end{aligned}$$

which shows that the action is indeed invariant under conformal transformations if ψ and $\bar{\psi}$ are primary fields of conformal dimension $\frac{1}{2}$. Furthermore, because we are studying a free theory, the engineering dimension $\frac{1}{2}$ agrees with the dimension in the quantum theory.

Finally, let us note that due to the fermionic nature of fields in our theory, there are two different possibilities for their behaviour under rotations by 2π . In particular, focussing on the chiral sector, on the complex plane we have

$$\begin{aligned}
\psi(e^{2\pi i} z) &= +\psi(z) && \text{Neveu-Schwarz sector (NS),} \\
\psi(e^{2\pi i} z) &= -\psi(z) && \text{Ramond sector (R).}
\end{aligned} \quad (2.104)$$

Radial Ordering and Laurent Expansion

Let us recall that our theory of the free fermion is defined on the complex plane with coordinate $z = x^0 + ix^1$, where x^0 and x^1 are coordinates of \mathbb{R}^2 . However, we have seen in Sect. 2.4 and explicitly for the example of the free boson, the quantum theory is usually defined on a cylinder of infinite length. Without providing a detailed derivation, let us just assume we started on a cylinder and have performed the mapping to the complex plane giving us our present theory.

This allows us in particular to introduce the concept of radial ordering also for the fermions. Taking into account the fermionic nature of the fields, we define

$$R(\Psi(z)\Theta(w)) := \begin{cases} +\Psi(z)\Theta(w) & \text{for } |z| > |w|, \\ -\Theta(w)\Psi(z) & \text{for } |w| > |z|. \end{cases} \quad (2.105)$$

Next, keeping in mind the conformal weight $\frac{1}{2}$ of our fields, we can perform a Laurent expansion of $\psi(z)$ in the usual way

$$\psi(z) = \sum_r \psi_r z^{-r-\frac{1}{2}}, \quad (2.106)$$

and similarly for the anti-chiral field. However, due to the two possibilities shown in Eq. (2.104), the values for r differ between the Neveu–Schwarz and Ramond sectors. It is easy to see that the following choice is consistent with Eq. (2.104):

$$\begin{aligned} r \in \mathbb{Z} + \frac{1}{2} & \quad \text{Neveu–Schwarz sector (NS),} \\ r \in \mathbb{Z} & \quad \text{Ramond sector (R).} \end{aligned}$$

OPE and Laurent Mode Algebra

Recalling our discussion on p. 34 together with the observation that $\psi(z)$ is a primary field of conformal dimension $\frac{1}{2}$, we can determine the following OPE:

$$\psi(z)\psi(w) = \frac{\kappa}{z-w} + \dots, \quad (2.107)$$

where the ellipsis denote non-singular terms. The normalisation constant of the two-point function κ is the same as in the action (2.102) which can be verified by computing the propagator of Eq. (2.102). Note furthermore that this OPE respects the fermionic property of ψ since interchanging $z \leftrightarrow w$ leads to a minus sign on the right-hand side which is obtained on the left-hand side by interchanging fermions. This fact also explains why there is no single fermion $\psi(z)$ on the right-hand side because $(z-w)^{-\frac{1}{2}}\psi(z)$ would not respect the fermionic nature of the OPE.

Let us now determine the algebra of the Laurent modes of $\psi(z)$. To do so, we recall that the modes in Eq. (2.106) can be expressed in the following way:

$$\psi_r = \oint \frac{dz}{2\pi i} \psi(z) z^{r-\frac{1}{2}}.$$

Because the fields under consideration are fermions, we are going to evaluate anti-commutators between the modes ψ_r and not commutators. Knowing the OPE (2.107), keeping in mind the radial ordering (2.105) and the deformation of contour integrals illustrated in Fig. 2.4, we calculate

$$\begin{aligned} \{\psi_r, \psi_s\} &= \oint \frac{dz}{2\pi i} \oint \frac{dw}{2\pi i} \{\psi(z), \psi(w)\} z^{r-\frac{1}{2}} w^{s-\frac{1}{2}} \\ &= \oint \frac{dw}{2\pi i} w^{s-\frac{1}{2}} \left(\oint_{|z|>|w|} \frac{dz}{2\pi i} \psi(z)\psi(w) z^{r-\frac{1}{2}} \right. \\ &\quad \left. - \oint_{|z|<|w|} \frac{dz}{2\pi i} -\psi(w)\psi(z) z^{r-\frac{1}{2}} \right) \\ &= \oint \frac{dw}{2\pi i} w^{s-\frac{1}{2}} \oint_{\mathcal{C}(w)} \frac{dz}{2\pi i} \underbrace{R(\psi(z)\psi(w))}_{\frac{\kappa}{z-w}} z^{r-\frac{1}{2}} \\ &= \kappa \oint \frac{dw}{2\pi i} w^{r+s-1} \\ &= \kappa \delta_{r+s,0}. \end{aligned} \tag{2.108}$$

Energy–Momentum Tensor

Let us also determine the energy–momentum tensor from the action (2.102). For fermionic theories, the definition of T_{ab} differs from the bosonic expression (2.84) and we would have to introduce additional structure to state the explicit form. Let us therefore provide a different but equivalent way to obtain the energy–momentum tensor. The *canonical* energy–momentum tensor for a theory with fields ϕ_i and Lagrangian \mathcal{L} is defined as

$$T_{\mu\nu}^c = 8\pi\kappa\gamma \left(-\eta_{\mu\nu} \mathcal{L} + \sum_i \frac{\partial \mathcal{L}}{\partial(\partial^\mu \phi_i)} \partial_\nu \phi_i \right),$$

where we allowed for a to be determined normalisation constant γ . However, in general T^c is not symmetric but can be made so using the equations of motion.

For the action (2.102), we can compute the canonical energy–momentum tensor using the metric (2.101) together with the observation that $\partial^z = 2\partial_{\bar{z}}$ as well as $\partial^{\bar{z}} = 2\partial_z$. We then find

$$T_{zz} = \gamma \psi \partial \psi, \quad T_{z\bar{z}} = -\gamma \bar{\psi} \partial \bar{\psi}, \quad T_{\bar{z}z} = -\gamma \psi \bar{\partial} \psi, \quad T_{\bar{z}\bar{z}} = \gamma \bar{\psi} \bar{\partial} \bar{\psi}.$$

We see that so far, the energy–momentum tensor is not symmetric, but using Eq. (2.103) shows that $T_{z\bar{z}} = T_{\bar{z}z} = 0$. In this way, we have arrived at the result

which we would have obtained using a modified form of Eq. (2.84). Focussing then only on the chiral part $T(z) = T_{zz}$ and using at the quantum level the normal ordered expression, we find

$$T(z) = \gamma N(\psi \partial \psi). \quad (2.109)$$

To compute the Laurent modes $L_m = \gamma N(\psi \partial \psi)_m$ of $T(z)$, we note that the derivation in Sect. 2.7 leading to expressions for normal ordered products was done for bosonic fields. For fermionic fields, we need to take into account the modified radial ordering prescription (2.105). Performing then the same analysis, we find for Eq. (2.67) in the case of fermionic fields

$$N(\psi \theta)_r = - \sum_{s > -h^\theta} \psi_{r-s} \theta_s + \sum_{s \leq -h^\theta} \theta_s \psi_{r-s}. \quad (2.110)$$

However, employing the same reasoning also for our expression involving derivatives (2.69), we can express the Laurent modes of the energy–momentum tensor (2.109) in the following way:

$$L_m = \gamma \sum_{s > -\frac{3}{2}} \psi_{m-s} \psi_s \left(s + \frac{1}{2}\right) - \gamma \sum_{s \leq -\frac{3}{2}} \psi_s \psi_{m-s} \left(s + \frac{1}{2}\right). \quad (2.111)$$

Let us now fix the constant γ by requiring $\psi(z)$ to be a primary field of conformal dimension $\frac{1}{2}$ with respect to the energy–momentum tensor (2.109). We therefore calculate the commutator between the modes L_m and the Laurent modes of the field $\psi(z)$

$$\begin{aligned} [L_m, \psi_r] &= + \gamma \sum_{s > -\frac{3}{2}} [\psi_{m-s} \psi_s, \psi_r] \left(s + \frac{1}{2}\right) \\ &\quad - \gamma \sum_{s \leq -\frac{3}{2}} [\psi_s \psi_{m-s}, \psi_r] \left(s + \frac{1}{2}\right) \\ &= + \gamma \sum_{s > -\frac{3}{2}} \left(s + \frac{1}{2}\right) \left(\psi_{m-s} \{\psi_s, \psi_r\} - \{\psi_{m-s}, \psi_r\} \psi_s\right) \\ &\quad - \gamma \sum_{s \leq -\frac{3}{2}} \left(s + \frac{1}{2}\right) \left(\psi_s \{\psi_{m-s}, \psi_r\} - \{\psi_s, \psi_r\} \psi_{m-s}\right) \\ &= + \gamma \kappa \sum_{s > -\frac{3}{2}} \left(s + \frac{1}{2}\right) \left(\psi_{m-s} \delta_{s,-r} - \psi_s \delta_{m-s,-r}\right) \\ &\quad - \gamma \kappa \sum_{s \leq -\frac{3}{2}} \left(s + \frac{1}{2}\right) \left(\psi_s \delta_{m-s,-r} - \psi_{m-s} \delta_{s,-r}\right) \end{aligned}$$

$$\begin{aligned}
&= +\gamma \kappa \left(\left(-r + \frac{1}{2} \right) \psi_{m+r} - \left(m + r + \frac{1}{2} \right) \psi_{m+r} \right) \\
&= +\gamma \kappa (-m - 2r) \psi_{m+r} .
\end{aligned}$$

If we then choose $\gamma \kappa = \frac{1}{2}$, we find

$$[L_m, \psi_r] = \left(-\frac{m}{2} - r \right) \psi_{m+r} ,$$

and by comparing with Eq. (2.45), we indeed see that $\psi(z)$ is a primary field of conformal dimension $h = \frac{1}{2}$ with respect to the energy–momentum tensor (2.109). In order to simplify the following formulas, let us in the following choose the usual normalisation:

$$\kappa = +1 .$$

The Central Charge

We will now compute the central charge c of the free fermion theory and start by recalling a general expression derived previously from the Virasoro algebra

$$\langle 0 | L_2 L_{-2} | 0 \rangle = \frac{c}{2} .$$

From Eq. (2.111), we then infer that

$$\begin{aligned}
L_{-2} | 0 \rangle &= \frac{1}{2} \psi_{-\frac{3}{2}} \psi_{-\frac{1}{2}} | 0 \rangle , & \langle 0 | L_2 &= \frac{1}{2} \langle 0 | \left(\psi_{\frac{3}{2}} \psi_{\frac{1}{2}} + 2 \psi_{\frac{1}{2}} \psi_{\frac{3}{2}} \right) \\
& & &= \frac{1}{2} \langle 0 | \left(\{ \psi_{\frac{3}{2}} , \psi_{\frac{1}{2}} \} + \psi_{\frac{1}{2}} \psi_{\frac{3}{2}} \right) \\
& & &= \frac{1}{2} \langle 0 | \psi_{\frac{1}{2}} \psi_{\frac{3}{2}} ,
\end{aligned}$$

and so we calculate using the anti-commutation relations (2.108)

$$\begin{aligned}
\frac{c}{2} &= \langle 0 | L_2 L_{-2} | 0 \rangle = \frac{1}{4} \langle 0 | \psi_{\frac{1}{2}} \psi_{\frac{3}{2}} \psi_{-\frac{3}{2}} \psi_{-\frac{1}{2}} | 0 \rangle \\
&= \frac{1}{4} \langle 0 | \psi_{\frac{1}{2}} \{ \psi_{\frac{3}{2}} , \psi_{-\frac{3}{2}} \} \psi_{-\frac{1}{2}} | 0 \rangle - 0 \\
&= \frac{1}{4} \langle 0 | \{ \psi_{\frac{1}{2}} , \psi_{-\frac{1}{2}} \} | 0 \rangle - 0 = \frac{1}{4} .
\end{aligned}$$

We therefore conclude that

The central charge of the conformal field theory given by a real free fermion is $c = \frac{1}{2}$.

Complex Fermions and Bosonisation

Let us now turn to a system with two real chiral fermions $\psi^{(1)}(z)$ and $\psi^{(2)}(z)$ which we combine into a complex chiral fermion in the following way:

$$\Psi(z) = \frac{1}{\sqrt{2}} \left(\psi^{(1)}(z) + i\psi^{(2)}(z) \right). \quad (2.112)$$

Note that we will always work with chiral quantities so we can denote the complex conjugate of $\Psi(z)$ by $\bar{\Psi}(z)$ which has, however, no relation with the anti-chiral part or the notation in Eq. (2.99). Furthermore, similarly to the real case, we can expand $\Psi(z)$ in a Laurent series as $\Psi(z) = \sum_r \Psi_r z^{-r-\frac{1}{2}}$ and we can easily check that the modes satisfy

$$\{\Psi_r, \Psi_s\} = \{\bar{\Psi}_r, \bar{\Psi}_s\} = 0, \quad \{\Psi_r, \bar{\Psi}_s\} = \delta_{r+s,0},$$

where we applied the same expansion also for $\bar{\Psi}(z)$. However, besides these two chiral fields of conformal dimension $h = \frac{1}{2}$, we find now an additional field in the theory which is expressed as

$$j(z) = N(\Psi\bar{\Psi})(z) = -i N(\psi^{(1)}\psi^{(2)})(z). \quad (2.113)$$

In order to write $j(z)$ in terms of the real fermions $\psi^{(1,2)}(z)$, we have used that $N(\psi^{(a)}\psi^{(b)}) = -N(\psi^{(b)}\psi^{(a)})$ with $a, b = 1, 2$. To verify this relation at the level of Laurent modes, we write out the normal ordered product (2.110) and perform the change $s \rightarrow -s + r$ in the summation index

$$\begin{aligned} N(\psi^{(a)}\psi^{(b)})_r &= - \sum_{s > -\frac{1}{2}} \psi_{r-s}^{(a)} \psi_s^{(b)} + \sum_{s \leq -\frac{1}{2}} \psi_s^{(b)} \psi_{r-s}^{(a)} \\ &= - \sum_{s < r + \frac{1}{2}} \psi_s^{(a)} \psi_{r-s}^{(b)} + \sum_{s \geq r + \frac{1}{2}} \psi_{r-s}^{(b)} \psi_s^{(a)} \\ &= - \sum_{s \leq -\frac{1}{2}} \psi_s^{(a)} \psi_{r-s}^{(b)} + \sum_{s > -\frac{1}{2}} \psi_{r-s}^{(b)} \psi_s^{(a)} - \sum_{s = \frac{1}{2}}^{r-\frac{1}{2}} \{\psi_s^{(a)}, \psi_{r-s}^{(b)}\} \\ &= -N(\psi^{(b)}\psi^{(a)})_r. \end{aligned}$$

Note that the sum over $\{\psi^{(a)}, \psi^{(b)}\} = \delta^{ab} \delta_{r,0}$ in the last line gives no contribution since the summand is only non-zero for $r = 0$ for which the sum disappears. Furthermore, because the modes in general do not (anti-)commute, one has to be careful when changing the summation index.

Let us proceed and perform a series expansion of Eq. (2.113) as $j(z) = \sum_n j_n z^{-n-1}$ and investigate the algebra of the modes j_n . Writing out the normal ordered product and noting that $\psi_r^{(1)}$ and $\psi_s^{(2)}$ anti-commute, we find

$$j_m = -i \sum_{r \in \mathbb{Z} + \frac{1}{2}} \psi_{m-r}^{(1)} \psi_r^{(2)} .$$

Here and in the rest of this paragraph, we concentrate on fermions in the Neveu–Schwarz sector with half-integer modes but the result in the Ramond sector is obtained in a similar fashion. Employing then that the energy–momentum tensor of $\Psi(z)$ is a sum of the individual ones, we calculate

$$\begin{aligned} [L_m, j_n] &= \sum_{s \in \mathbb{Z} + \frac{1}{2}} [L_m^{(1)} + L_m^{(2)}, -i \psi_{n-s}^{(1)} \psi_s^{(2)}] \\ &= \sum_{s \in \mathbb{Z} + \frac{1}{2}} \left(-i [L_m^{(1)}, \psi_{n-s}^{(1)}] \psi_s^{(2)} - i \psi_{n-s}^{(1)} [L_m^{(2)}, \psi_s^{(2)}] \right) \\ &= \sum_{s \in \mathbb{Z} + \frac{1}{2}} \left(-\left(-\frac{m}{2} - n + s\right) i \psi_{m+n-s}^{(1)} \psi_s^{(2)} - i \psi_{n-s}^{(1)} \left(-\frac{m}{2} - s\right) \psi_{m+s}^{(2)} \right) \\ &= -n j_{m+n} , \end{aligned}$$

where in going from the third to the last line we performed a redefinition $s \rightarrow s - m$ in the last summand. Note that this equation is the statement that $j(z)$ defined above is a primary field of conformal dimension $h = 1$ and thus a current. Let us then move on and determine the current algebra

$$\begin{aligned} [j_m, j_n] &= \sum_{r, s \in \mathbb{Z} + \frac{1}{2}} -[\psi_{m-s}^{(1)} \psi_s^{(2)}, \psi_{n-r}^{(1)} \psi_r^{(2)}] \\ &= \sum_{r, s \in \mathbb{Z} + \frac{1}{2}} \left(\psi_{m-s}^{(1)} \psi_{n-r}^{(1)} \{ \psi_s^{(2)}, \psi_r^{(2)} \} - \psi_r^{(2)} \psi_s^{(2)} \{ \psi_{n-r}^{(1)}, \psi_{m-s}^{(1)} \} \right) \\ &= \sum_{r \in \mathbb{Z} + \frac{1}{2}} \left(\psi_{m+r}^{(1)} \psi_{n-r}^{(1)} - \psi_r^{(2)} \psi_{n+m-r}^{(2)} \right) . \end{aligned}$$

In order to proceed, we have to perform a careful analysis of the first term in the sum above. As mentioned above, because of the fermions do in general not anti-commute, we cannot simply shift the summation index but have to also take care of the normal ordering. We find

$$\begin{aligned}
\sum_{r \in \mathbb{Z} + \frac{1}{2}} \psi_{m+r} \psi_{n-r} &= \sum_{r \leq -\frac{1}{2}+n} \psi_{m+r} \psi_{n-r} + \sum_{r \geq \frac{1}{2}+n} \psi_{m+r} \psi_{n-r} \\
&= \sum_{r \leq -\frac{1}{2}+n} \psi_{m+r} \psi_{n-r} - \sum_{r \geq \frac{1}{2}+n} \psi_{n-r} \psi_{m+r} + \sum_{r \geq \frac{1}{2}+n} \{\psi_{m+r}, \psi_{n-r}\} \\
&= \sum_{r = \frac{1}{2}-m}^{-\frac{1}{2}+n} \psi_{m+r} \psi_{n-r} + \sum_{r \geq \frac{1}{2}+n} \delta_{m+n,0} = \sum_{r \geq \frac{1}{2}+n} \delta_{m+n,0} ,
\end{aligned}$$

where the step from the second to the third line can be understood by relabelling $r \rightarrow -r + n - m$ in the second sum. Furthermore, the last step is easily verified using the anti-commutation relation for fermions. With this result, we arrive at

$$[j_m, j_n] = \sum_{r \geq \frac{1}{2}+n} \delta_{m+n,0} - \sum_{r \geq \frac{1}{2}+m+n} \delta_{m+n,0} = \sum_{r = \frac{1}{2}+n}^{-\frac{1}{2}+m+n} \delta_{m+n,0} = m \delta_{m+n,0} .$$

A current satisfying this algebra is called a $U(1)$ current and we will study such theories in more detail in Chap. 3. However, let us finally determine the $U(1)$ charge of the complex fermion $\Psi(z)$ and its complex conjugate $\bar{\Psi}(z)$. To do so, we calculate

$$\begin{aligned}
[j_m, \Psi_s] &= \sum_{r \in \mathbb{Z} + \frac{1}{2}} \left[-i \psi_{m-r}^{(1)} \psi_r^{(2)}, \frac{1}{\sqrt{2}} (\psi_s^{(1)} + i \psi_s^{(2)}) \right] \\
&= \frac{1}{\sqrt{2}} \sum_{r \in \mathbb{Z} + \frac{1}{2}} \left(i \{ \psi_{m-r}^{(1)}, \psi_s^{(1)} \} \psi_r^{(2)} + \psi_{m-r}^{(1)} \{ \psi_r^{(2)}, \psi_s^{(2)} \} \right) \\
&= +\Psi_{m+s} ,
\end{aligned}$$

and for $\bar{\Psi}(z)$, we find along the same lines that $[j_m, \bar{\Psi}_s] = -\bar{\Psi}_{m+s}$. Therefore, the complex fields carry charge ± 1 under the current $j(z)$. Let us now summarise the algebra generated by the complex fermions $\Psi(z)$ and $\bar{\Psi}(z)$ defined in Eq. (2.112) and the current $j(z)$ defined in Eq. (2.113) as

$ \begin{aligned} \{\Psi_m, \bar{\Psi}_n\} &= \delta_{m+n,0} , & \{\Psi_m, \Psi_n\} &= \{\bar{\Psi}_m, \bar{\Psi}_n\} = 0 , \\ [j_m, j_n] &= m \delta_{m+n,0} , & [L_m, j_n] &= -n j_{m+n} , \\ [j_m, \Psi_s] &= +\Psi_{m+s} , & [j_m, \bar{\Psi}_s] &= -\bar{\Psi}_{m+s} . \end{aligned} $	(2.114)
---	---------

Note that this algebra can also be realised by a free boson $X(z, \bar{z})$ compactified on a circle of radius $R = 1$ for which, focussing only on the holomorphic part, we have the following fields:

$$j(z) = i \partial X(z, \bar{z}), \quad j^\pm(z) = V_{\pm 1}(z) =: e^{\pm iX} : .$$

As we have seen before, the chiral field $j(z)$ has conformal dimension $h = 1$ and for the vertex operators $j^\pm(z)$, we find $h = \frac{1}{2}$ using $h = \frac{\alpha^2}{2}$ with $\alpha = \pm 1$. The algebra of $j(z)$ and $j^\pm(z)$ can be determined using the general expressions (2.54) and (2.55) for the commutation relations of quasi-primary fields. In particular, the only non-vanishing constants $p_{ijk}(m, n)$ of Eq. (2.55) are found to be

$$p_{\frac{1}{2}1\frac{1}{2}}(m, n) = 1, \quad p_{111}(m, n) = 1,$$

where the subscripts label the conformal dimension of the fields. By the same argument as before, since the overall charge in a correlation function has to vanish, we find for the two-point functions that

$$d_{jj} = d_{+-} = d_{-+} = 1, \quad d_{j\pm} = d_{\pm\pm} = 0,$$

where we employed the usual normalisation. Applying the same argument to the three-point function, we find that $C_{-j+} = -C_{+j-} = 1$. Together with the anti-symmetry $C_{ij}^k = -C_{ji}^k$ and the relation $C_{ij}^l d_{lk} = C_{ij}^k$, we conclude that the non-vanishing structure constants are

$$C_{j+}^+ = -C_{+j}^+ = +1, \quad C_{j-}^- = -C_{-j}^- = -1.$$

Using these results in the general expression (2.54), we can easily write down the algebra of Laurent modes of the fields $j(z)$ and $j^\pm(z)$

$$\begin{aligned} [j_m, j_n] &= m \delta_{m+n}, & [J_m^+, J_n^-] &= \delta_{m+n, 0}, \\ [j_m, j_n^\pm] &= \pm j_{m+n}^\pm, & [j_m^\pm, j_n^\pm] &= 0. \end{aligned}$$

By comparing with Eq. (2.114), we see that the algebra of a complex fermion can indeed be realised in terms of a free boson.

It is not surprising that a theory of a boson can equivalently be expressed as a theory of two fermions, but it is very special to conformal field theories that we can also express the fermions in terms of the boson. This is called the bosonisation of a complex fermion. We note in passing that this intriguing relation has been used in the so-called covariant lattice approach to string theory model building.

Hilbert Space

Let us finally turn to the Hilbert space \mathcal{H} of the free fermion theory. For the Neveu-Schwarz sector, we find the following chiral states:

$$|0\rangle, \quad \psi_{-\frac{1}{2}} |0\rangle, \quad \underbrace{\psi_{-\frac{1}{2}} \psi_{-\frac{1}{2}}}_{=0} |0\rangle, \quad \psi_{-\frac{3}{2}} |0\rangle, \quad \psi_{-\frac{3}{2}} \psi_{-\frac{1}{2}} |0\rangle, \quad \dots,$$

where we have used that $\{\psi_r, \psi_s\} = \delta_{r,-s}$. In particular, due to Fermi-statistics, each mode ψ_r can only appear once. Taking also the anti-chiral sector into account, we can conclude that in the Neveu–Schwarz sector, the Hilbert space is

$$\mathcal{H}_{\text{NS}} = \left\{ \text{Fock space freely generated by } \psi_{-r}, \bar{\psi}_{-s} \text{ for } r, s \geq \frac{1}{2} \right\}.$$

The generating function for the degeneration of states at each level N in the chiral sector can be shown to be of the form

$$\mathcal{Z}_{\text{NS}}(q) = \prod_{r \geq 0} \left(1 + q^{r+\frac{1}{2}} \right) = \sum_{N \in \frac{1}{2}\mathbb{Z}} P(N) q^N.$$

We will perform a detailed study of these expressions in Chap. 4. In the Ramond sector, that is, for $r \in \mathbb{Z}$, there will be fermionic zero modes ψ_0 which deserve a special treatment. This issue will be discussed in Sect. 4.2.4.

2.9.3 The (b,c) Ghost Systems

After having studied the free boson and the free fermion conformal field theories, we will now briefly consider the (b, c) ghost system which plays an important role in the covariant quantisation of the bosonic string.

Basic Properties

Let us start on the complex plane for which we have the metric shown in Eq. (2.101). The action of the (b, c) ghost system reads

$$\mathcal{S} = \frac{1}{4\pi} \int d^2z \left(b_{zz} \partial^z c^z + b_{\bar{z}\bar{z}} \partial^{\bar{z}} c^{\bar{z}} \right), \quad (2.115)$$

where $\partial^z = 2\partial_{\bar{z}}$ and $\partial^{\bar{z}} = 2\partial_z$ due to the metric (2.101). Here the fields b and c are primary free bosonic fields of conformal dimension $h^b = 2$ and $h^c = -1$ satisfying the wrong spin-statistics relation, that is, they are anti-commuting bosons.

The equation of motion is obtained in the usual way by varying the action above with respect to b and c . Since the calculation is similar to the ones we have presented previously, we just state the results

$$\begin{aligned}
\partial_{\bar{z}} b_{zz} &= 0 &\Rightarrow & b_{zz} = b(z) , \\
\partial_z b_{\bar{z}\bar{z}} &= 0 &\Rightarrow & b_{\bar{z}\bar{z}} = \bar{b}(\bar{z}) , \\
\partial_{\bar{z}} c^z &= 0 &\Rightarrow & c^z = c(z) , \\
\partial_z c^{\bar{z}} &= 0 &\Rightarrow & c^{\bar{z}} = \bar{c}(\bar{z}) ,
\end{aligned}$$

where we also indicated a new notation for the holomorphic and anti-holomorphic fields. Taking into account the conformal dimensions of these fields, we perform a Laurent expansion in the following way:

$$b(z) = \sum_{n \in \mathbb{Z}} b_n z^{-n-2} , \quad c(z) = \sum_{n \in \mathbb{Z}} c_n z^{-n+1} ,$$

and similarly for the anti-chiral fields. Note also that the modes satisfy $b_n |0\rangle = 0$ for $n > -2$ and $c_n |0\rangle = 0$ for $n > 1$.

Let us finally determine the propagator of this theory given by the action (2.115). The condition to be satisfied for the propagator as well as its solution read

$$\partial^z \langle b(z)c(w) \rangle = 4\pi \delta^{(2)}(z-w) \quad \Rightarrow \quad \langle b(z)c(w) \rangle = \frac{1}{z-w} .$$

Recalling Eq. (2.53) and taking into account the anti-commuting property of the fields, we can conclude that the OPE has the form

$$b(z)c(w) = \frac{1}{z-w} + \dots ,$$

from which we can determine the anti-commutation relation of the Laurent modes by employing $b_n = \frac{1}{2\pi i} \oint dz z^{n+1} b(z)$ as well as $c_n = \frac{1}{2\pi i} \oint dz z^{n-2} c(z)$. We then find

$$\{b_m, c_n\} = \delta_{n+m,0} , \quad \{b_m, b_n\} = 0 , \quad \{c_m, c_n\} = 0 . \quad (2.116)$$

Energy–Momentum Tensor and Central Charge

As we have argued on general grounds, the energy–momentum tensor has conformal dimension $h = 2$ which of course also applies to the (b, c) ghost system. Without providing a detailed derivation for the energy–momentum tensor, we simply make an ansatz for $T(z)$ similar to the free fermion

$$T(z) = \alpha N(b \partial c) + \beta N(\partial b c) ,$$

and fix the constants α and β by requiring $h^b = 2$ and $h^c = 1$. Using our formula for the Laurent modes of normal ordered products involving derivatives (2.69) and keeping in mind the anti-commuting property of the fields, we find

$$\begin{aligned}
L_m = & +\alpha \left(-\sum_{k>0} b_{m-k} c_k (+1-k) + \sum_{k\leq 0} (+1-k) c_k b_{m-k} \right) \\
& +\beta \left(-\sum_{k>1} b_{m-k} c_k (-2-m+k) + \sum_{k\leq 1} c_k b_{m-k} (-2-m+k) \right). \tag{2.117}
\end{aligned}$$

With the help of the anti-commutation relations (2.116), we can then compute

$$\begin{aligned}
L_0 |b\rangle &= L_0 b_{-2} |0\rangle = \{L_0, b_{-2}\} |0\rangle = \alpha b_{-2} \{c_2, b_{-2}\} |0\rangle = \alpha |b\rangle \\
L_0 |c\rangle &= L_0 c_1 |0\rangle = \{L_0, c_1\} |0\rangle = -\beta c_1 \{b_{-1}, c_1\} |0\rangle = -\beta |c\rangle
\end{aligned}$$

from which we conclude that $\alpha = 2$ and $\beta = 1$. Knowing the energy-momentum tensor, we can finally compute the central charge of the (b, c) ghost system. As in the previous examples, we first note that $L_2 L_{-2} |0\rangle = \frac{c}{2} |0\rangle$. From Eq. (2.117), we find

$$L_{-2} |0\rangle = 2 c_0 b_{-2} |0\rangle + c_1 b_{-3} |0\rangle.$$

Furthermore, we have

$$\begin{aligned}
L_2 = & 2 \left(-\sum_{k>0} b_{2-k} c_k (-k+1) + \sum_{k\leq 0} (-k+1) c_k b_{2-k} \right) \\
& + \left(-\sum_{k>1} (-(2-k)-2) b_{2-k} c_k + \sum_{k\leq 1} (-(2-k)-2) c_k b_{2-k} \right).
\end{aligned}$$

The only terms in L_2 which do not commute with L_{-2} and therefore do not annihilate $|0\rangle$ are those involving (c_2, b_0) as well as those with (c_3, b_{-1}) . We therefore extract the relevant expressions from L_2 in the following way:

$$L_2 = 2 (b_0 c_2 + 2 b_{-1} c_3) + (2 b_0 c_2 + b_{-1} c_3) + \dots = 4 b_0 c_2 + 5 b_{-1} c_3 + \dots$$

from which we calculate

$$L_2 L_{-2} |0\rangle = 8 b_0 c_2 c_0 b_{-2} |0\rangle + 5 b_{-1} c_3 c_1 b_{-3} |0\rangle = (-8 - 5) |0\rangle = -13 |0\rangle.$$

Comparing now with $L_2 L_{-2} |0\rangle = \frac{c}{2} |0\rangle$, we arrive at the result that

The central charge of the (b, c) ghost system conformal field theory is $c = -26$.

Remark

The result that the (b, c) ghost system has central charge $c = -26$ is the reason for the statement that the bosonic string is free of anomalies only in $D = 26$ flat space–time dimensions, because the CFT of a single free boson has central charge $c = 1$. For Superstring Theory, each free boson X^μ is paired with one free fermion ψ^μ , where $\mu = 0, \dots, D$. In this case, in addition to the (b, c) ghost system, also commuting fermionic ghosts (β, γ) of conformal dimensions $(3/2, -1/2)$ have to be included. The central charge of this sector is determined as $c = 11$, so that the superstring can be consistently quantised in $D = \frac{2}{3}(26 - 11) = 10$ dimensions where the factor $\frac{2}{3}$ comes from the central charge $c = 1 + \frac{1}{2} = \frac{3}{2}$ of a single boson–fermion pair.

2.10 Highest Weight Representations of the Virasoro Algebra

After having studied in detail three examples of conformal field theories, our aim in the present section is to study the representation theory of the symmetry algebra $\mathcal{A} \oplus \overline{\mathcal{A}}$ on general grounds. Here, \mathcal{A} denotes the chiral sector, while $\overline{\mathcal{A}}$ stands for the anti-chiral part. In particular, we will focus on the minimal case with \mathcal{A} and $\overline{\mathcal{A}}$ being the Virasoro algebra generated by $T(z)$ and $\overline{T}(\bar{z})$, respectively. However, it is possible for CFTs to have larger symmetry algebras, for instance the so-called \mathcal{W} algebras, which we will consider in Sect. 3.7.

Highest Weight Representations and Verma Module

Analogously to the $\mathfrak{su}(2)$ spin algebra in Quantum Mechanics, we want to construct highest weight representations (HWR) of the Virasoro algebra. As we have seen in Eqs. (2.62) and (2.73), a highest weight state $|h\rangle$ corresponding to a primary field of conformal dimension h has the property

$$\begin{aligned} L_n |h\rangle &= 0 \quad \text{for} \quad n > 0, \\ L_0 |h\rangle &= h |h\rangle, \end{aligned} \tag{2.118}$$

so that the action of L_n for $n < 0$ on the state $|h\rangle$ creates new states. The set of all these states is called the *Verma module* $V_{h,c}$, where h stands for the highest weight state $|h\rangle$ and c is the central charge of the Virasoro algebra. The lowest level states in the Verma module $V_{h,c}$ are

$$L_{-1}|h\rangle, \quad L_{-2}|h\rangle, \quad L_{-1}L_{-1}|h\rangle, \quad L_{-3}|h\rangle, \quad \dots$$

Roughly speaking, the Verma module $V_{h,c}$ is the set of states corresponding to the conformal family $[\phi(z)]$ of a primary field $\phi(z)$ with conformal dimension h .

Depending on the combination (h, c) , there can be states of vanishing or even of negative norm in a Verma module. For unitary theories, the later should be absent and vanishing norm states should be removed from $V_{h,c}$. However, it turns out that states of vanishing norm generate an independent Verma module which is “orthogonal” to the parent one. We will not go into further detail but refer to the existing literature.

Null States and the Kač-Determinant

To illustrate how to determine zero-norm states in a Verma module, we are going to consider a simple example from linear algebra. Suppose we have a vector $|v\rangle$ in a real n -dimensional vector space with basis vectors $|a\rangle$. Note that in particular, this basis does not need to be orthonormal. We then express our vector as $|v\rangle = \sum_{a=1}^n \lambda_a |a\rangle$ where not all λ_a are zero. The condition for $|v\rangle$ to have vanishing norm is

$$0 = \|v\|^2 = \sum_{a,b=1}^n \lambda_a \langle a|b\rangle \lambda_b = \sum_{a,b=1}^n \lambda_a M_{ab} \lambda_b = \vec{\lambda}^T M \vec{\lambda}$$

where we defined the elements of the matrix M as $M_{ab} = \langle a|b\rangle$. This expression is zero if $\vec{\lambda}$ is an eigenvector of M with eigenvalue zero. The number of such (linearly independent) eigenvectors is given by the number of roots of the equation $\det M = 0$.

Let us now come back to the null states in the Verma module. Analogously to the example above, to decide whether there exist zero-norm states, we are going to compute the so-called *Kač-determinant* at level N . We denote the corresponding matrix as $M_N(h, c)$ where the entries are defined as the product of states in the Verma module

$$\langle h | \prod_i L_{+k_i} \prod_j L_{-m_j} | h \rangle, \quad \sum_i k_i = \sum_j m_j = N,$$

with all $k_i, m_j \geq 0$. Note that the condition on the right-hand side guarantees that we are considering only states at level N . For two states at different level, the corresponding matrix element vanishes because the net number of operators $\sum_i k_i - \sum_j m_j$ is non-zero and so only creation or only annihilation operators survive.

Let us illustrate this procedure for the first and second level. For $N = 1$, we have only one state in the Verma module and so we find

$$M_1(h, c) = \langle h | L_1 L_{-1} | h \rangle = 2 \langle h | L_0 | h \rangle = 2h.$$

The Kač-determinant is therefore trivially

$$\det M_1(h, c) = 2h .$$

Here we see that for $h = 0$, we have one null state at level $N = 1$. At level $N = 2$, there are the two states $L_{-2} |h\rangle$ and $L_{-1} L_{-1} |h\rangle$ in the Verma module. For the elements of the two-by-two matrix $M_2(h, c)$, we use Eq. (2.118) to calculate

$$\begin{aligned} \langle h | L_2 L_{-2} | h \rangle &= \langle h | \frac{c}{2} + 4 L_0 | h \rangle = 4h + \frac{c}{2} , \\ \langle h | L_1 L_1 L_{-2} | h \rangle &= \langle h | L_1 \cdot 3 L_{-1} | h \rangle = 6h , \\ \langle h | L_2 L_{-1} L_{-1} | h \rangle &= \langle h | 3 L_1 \cdot L_{-1} | h \rangle = 6h , \\ \langle h | L_1 L_1 L_{-1} L_{-1} | h \rangle &= \langle h | L_1 [L_1, L_{-1}] L_{-1} | h \rangle + \langle h | L_1 L_{-1} L_1 L_{-1} | h \rangle \\ &= \langle h | L_1 2 L_0 L_{-1} | h \rangle + \langle h | [L_1, L_{-1}] [L_1, L_{-1}] | h \rangle \\ &= 2 \langle h | L_1 [L_0, L_{-1}] | h \rangle + 4h^2 + 4h^2 \\ &= 4h + 8h^2 . \end{aligned}$$

For the Kač-determinant at level $N = 2$, we then find

$$\det M_2(c, h) = \det \begin{pmatrix} 4h + \frac{c}{2} & 6h \\ 6h & 4h(2h + 1) \end{pmatrix} = 32h \left(h^2 - \frac{5}{8}h + \frac{1}{8}hc + \frac{1}{16}c \right) .$$

The roots of $\det M_2(c, h)$ are the following:

$$\begin{aligned} h_{1,2} &= \frac{5-c}{16} - \frac{1}{16} \sqrt{(1-c)(25-c)} , \\ h_{1,1} &= 0 , \\ h_{2,1} &= \frac{5-c}{16} + \frac{1}{16} \sqrt{(1-c)(25-c)} , \end{aligned}$$

where our notation will become clear in the following. We can then write the Kač-determinant as

$$\det M_2(c, h) = 32 \left(h - h_{1,1}(c) \right) \left(h - h_{1,2}(c) \right) \left(h - h_{2,1}(c) \right) .$$

In summary, at level $N = 2$, we found three states of vanishing norm where the root $h_{1,1} = 0$ is due to the null state at level 1. This is a general feature: if a null state $|h + n\rangle$ occurs at level n , then at level $N > n$ there are $P(N - n)$ resulting null states. Here $P(n)$ is again the number of partitions of n .

V. Kač found and proved the general formula for the determinant $\det M_N(c, h)$ at arbitrary level N .

The so-called Kač-determinant at level N reads

$$\det M_N(c, h) = \alpha_N \prod_{\substack{p, q \leq N \\ p, q > 0}} (h - h_{p, q}(c))^{P(N-pq)}$$

with

$$h_{p, q}(m) = \frac{((m + 1)p - mq)^2 - 1}{4m(m + 1)}, \quad m = -\frac{1}{2} \pm \frac{1}{2} \sqrt{\frac{25 - c}{1 - c}}.$$

Here, α_N is a positive constant and we note that in general, m is not an integer but complex. For $c < 1$, one conventionally chooses the branch $m \in (0, \infty)$; however, $h_{p, q}$ possesses the symmetry $\{p \rightarrow m - p, q \rightarrow m + 1 - q\}$ so that $\det M_N$ is independent of the choice of branch in m as it can be compensated by $p \leftrightarrow q$.

Unitary Representations

So far, we have focused on the null states in a Verma module. However, to find unitary representations we have to exclude also the regions in the (h, c) -plane where states of negative norm appear. We will not discuss all the details but just summarise the results.

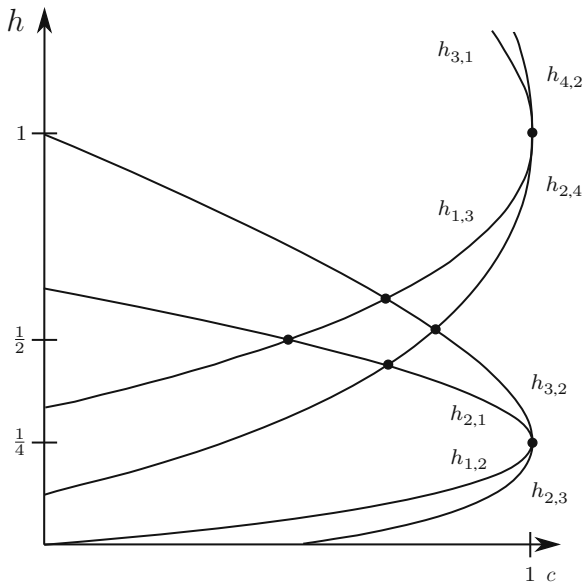

Fig. 2.6 Some curves $h_{p, q}(c)$ of vanishing Kač-determinant. Unitary representations are labelled by a dot

- For $c > 1$ and $h \geq 0$, there are no zeros and all eigenvalues of M_N are positive. Therefore, unitary representations can exist.
- In the case of $c = 1$, one finds $\det M_N = 0$ for $h = \frac{n^2}{4}$ where $n \in \mathbb{Z}$.
- The region $c < 1$ and $h \geq 0$ is much more complicated. It can be shown that all points which do not lie on a curve $h_{p,q}(c)$ where $\det M_N = 0$ are non-unitary. A more careful analysis reveals that in fact non-negative states are absent only on certain intersection points of such vanishing curves. This is illustrated in Fig. 2.6 where the dots stand for unitary representations.

We can summarise the results as follows:

For the case of $c < 1$ and $h \geq 0$, the discrete set of points where unitary representations are not excluded occur at values of c

$$c = 1 - \frac{6}{m(m+1)} \quad m = 3, 4, \dots$$

To each c there are only $\binom{m}{2}$ allowed values of h

$$h_{p,q}(m) = \frac{((m+1)p - mq)^2 - 1}{4m(m+1)} \quad (2.119)$$

with $1 \leq p \leq m-1$ and $1 \leq q \leq m$.

So far, this condition is only necessary. But we will see later that concrete conformal field theories can indeed be found.

Because of the severe constraints on unitary CFTs, only a discrete set of values c with a finite number of highest weight representations survive. conformal field theories with this latter property are known to exist only for rational values of the central charge and are therefore called Rational CFTs or RCFTs.

Examples

To close this section, let us consider some examples for the case $c < 1$ and $h \geq 0$. For $m = 3$, we find $c = \frac{1}{2}$ as well as $1 \leq p \leq 2$ and $1 \leq q \leq 3$. The possible values of $h_{p,q}$ are then conveniently organised in the so-called conformal grid

$q \uparrow$	$\frac{1}{2}$	0	
	$\frac{1}{16}$	$\frac{1}{16}$	
	0	$\frac{1}{2}$	$\rightarrow p$

which in the present case describes the critical point of the second-order phase transition of the Ising model. For the case of $m = 4$, we find $c = \frac{7}{10}$ which is the tri-critical Ising model. The conformal grid is displayed below.

$\frac{3}{2}$	$\frac{7}{10}$	0
$\frac{3}{5}$	$\frac{3}{80}$	$\frac{1}{10}$
$\frac{1}{10}$	$\frac{3}{18}$	$\frac{3}{5}$
0	$\frac{7}{16}$	$\frac{3}{2}$

Finally, for $m = 5$, we get $c = \frac{4}{5}$ which is the three states Potts model.

Remarks

- Note that for deriving the results in this section, we have not referred at any stage to a concrete realisation of a CFT, but have solely exploited the consequences of conformal symmetry. This shows the far-reaching consequences of the conformal symmetry in two dimensions.
- For Euclidean CFTs and their application to statistical models, unitarity, that is, reflection positivity, is not a necessary condition. Weakening this constraint and allowing for states with negative norm, the representation theory of the Virasoro algebra contains a more general discrete series of RCFTs. These are given by the central charges

$$c = 1 - 6 \frac{(p - q)^2}{pq} \quad (2.120)$$

with the $p, q \geq 2$ and p, q relatively coprime. The finite set of highest weights is given by

$$h_{r,s}(p, q) = \frac{(pr - qs)^2 - (p - q)^2}{4pq}$$

with $1 \leq r \leq q - 1$ and $1 \leq s \leq p - 1$. Unless $|p - q| = 1$, there always exist highest weight states of negative norm, and the unitary series is precisely given by $p = m + 2$, $q = m + 3$ with $m \geq 1$. As an example, note that the model $(p, q) = (5, 2)$ with central charge $c = -22/5$ describes the Yang–Lee edge singularity.

- Note that the theories defined by Eq. (2.120) are called *minimal models*. In the case of $p = m + 2$, $q = m + 3$ with $m \geq 1$, i.e. if the theory is unitary, they are called unitary (minimal) models.

2.11 Correlation Functions and Fusion Rules

In this section, we are going to discuss one of the most powerful results of the boot-strap approach to CFTs. We will see that the appearance of null states in the unitary models with $0 < c < 1$ severely restricts the form of the OPEs between the primary fields $\phi_{(p,q)}$.

Null States at Level Two

We start by discussing the null states at level $N = 2$. Note that in the previous section, we did not determine their precise form, however, in general such a state is a linear combination written in the following way:

$$L_{-2} |h\rangle + a L_{-1} L_{-1} |h\rangle = 0. \quad (2.121)$$

If we apply L_1 to this equation, we can fix the constant a as

$$\begin{aligned} 0 &= [L_1, L_{-2}] |h\rangle + a [L_1, L_{-1} L_{-1}] |h\rangle \\ &= 3 L_{-1} |h\rangle + a (2 L_0 L_{-1} + 2 L_{-1} L_0) |h\rangle \\ &= (3 + 2a(2h + 1)) L_{-1} |h\rangle \end{aligned} \quad \Rightarrow \quad a = -\frac{3}{2(2h + 1)}$$

where we used that $L_{-1}|h\rangle \neq 0$ for $h \neq 0$. Next, we apply L_2 to Eq. (2.121) in order to determine the allowed values for h

$$\begin{aligned} 0 &= [L_2, L_{-2}] |h\rangle + a [L_2, L_{-1} L_{-1}] |h\rangle \\ &= \left(4 L_0 + \frac{c}{2}\right) |h\rangle + a L_{-1} [L_2, L_{-1}] |h\rangle + a [L_2, L_{-1}] L_{-1} |h\rangle \\ &= \left(4h + \frac{c}{2}\right) |h\rangle + 6ah |h\rangle \\ &= \left(4h + \frac{c}{2} + 6ah\right) |h\rangle \end{aligned} \quad \Rightarrow \quad c = \frac{2h}{2h + 1} (5 - 8h).$$

Therefore, we have shown that for a theory with central charge $c = \frac{2h}{2h+1}(5 - 8h)$ the null state at level $N = 2$ satisfies

$$\left(L_{-2} - \frac{3}{2(2h + 1)} L_{-1}^2\right) |h\rangle = 0. \quad (2.122)$$

Let us quickly check Eq. (2.122) for the unitary series from the last section. We found that in theories with central charges $c = 1 - \frac{6}{m(m+1)}$, $m \geq 3$, there is a highest weight at level two characterised by

$$h_{2,1}(m) = \frac{(2(m+1) - m)^2 - 1}{4m(m+1)} = \frac{(m+2)^2 - 1}{4m(m+1)}.$$

Solving this equation for m leads to $m = \frac{3}{4h-1}$, which gives a central charge $c = \frac{2h(5-8h)}{2h+1}$ in agreement with our result above.

Descendant Fields and Correlation Functions

We already mentioned that the fields in the Verma module obtained by acting with L_m are called *descendant fields* and we will now formalise the concept of descendants to some extent. Given a primary field $\phi(w)$, the descendant fields $\widehat{L}_{-n}\phi$ for $n > 0$ are defined to be the fields appearing in the OPE

$$T(z)\phi(w) = \sum_{n \geq 0} (z-w)^{n-2} \widehat{L}_{-n}\phi(w).$$

Performing a contour integration, we find for the descendant fields

$$\widehat{L}_{-n}\phi(w) = \oint \frac{dz}{2\pi i} \frac{1}{(z-w)^{n-1}} T(z)\phi(w). \quad (2.123)$$

If the conformal dimension of ϕ is integer, we can determine the descendant fields for the first values of n from Eq. (2.40) as

$$\widehat{L}_0\phi(w) = h\phi(w), \quad \widehat{L}_{-1}\phi(w) = \partial\phi(w), \quad \widehat{L}_{-2}\phi(w) = N(\phi T)(w). \quad (2.124)$$

Let us now derive an expression for the correlator of a descendant field with a number of other primaries. For convenience, we work with chiral primaries, however, the result for the anti-chiral part is obtained along similar lines. We use Eq. (2.123) for the descendant field and the deformation of contours illustrated in Fig. 2.7 to find

$$\begin{aligned} & \langle \widehat{L}_{-n}\phi(w)\phi_1(w_1)\dots\phi_N(w_N) \rangle \\ &= \oint_{\mathcal{C}(w)} \frac{dz}{2\pi i} (z-w)^{1-n} \langle (T(z)\phi(w))\phi_1(w_1)\dots\phi_N(w_N) \rangle \\ &= - \sum_{i=1}^N \oint_{\mathcal{C}(w_i)} \frac{dz}{2\pi i} (z-w)^{1-n} \langle \phi(w)\phi_1(w_1)\dots(T(z)\phi_i(w_i))\dots\phi_N(w_N) \rangle \\ &= - \sum_{i=1}^N \oint_{\mathcal{C}(w_i)} \frac{dz}{2\pi i} (z-w)^{1-n} \times \\ & \quad \times \left(\frac{h_i}{(z-w_i)^2} + \frac{1}{z-w_i} \partial_{w_i} \right) \langle \phi(w)\phi_1(w_1)\dots\phi_N(w_N) \rangle \\ &= - \sum_{i=1}^N \left((1-n)(w_i-w)^{-n} h_i + (w_i-w)^{1-n} \partial_{w_i} \right) \langle \phi(w)\phi_1(w_1)\dots\phi_N(w_N) \rangle, \end{aligned}$$

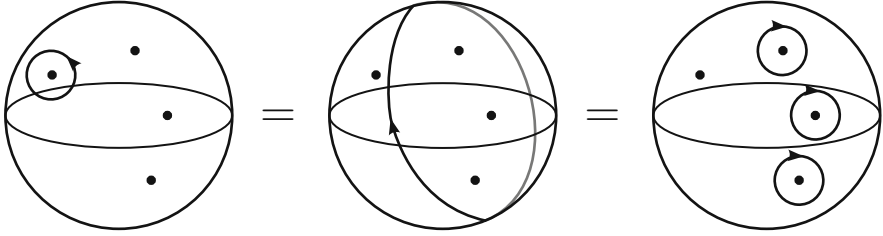

Fig. 2.7 Transformation of contour integrals on the sphere. Note that the orientation on the very right is clock-wise so the residue picks up a minus sign

where from the third to the fourth line we used the OPE of a primary field and in the last step we employed the residue theorem. We have therefore shown that

The correlator involving a descendant field $\widehat{L}_{-n}\phi$ can be computed from the correlator involving the corresponding primary field ϕ by applying the differential operator \mathcal{L}_{-n} in the following way:

$$\langle \widehat{L}_{-n} \phi(w) \phi_1(w_1) \dots \phi_N(w_N) \rangle = \mathcal{L}_{-n} \langle \phi(w) \phi_1(w_1) \dots \phi_N(w_N) \rangle$$

where the operator \mathcal{L}_{-n} has the form

$$\mathcal{L}_{-n} = \sum_{i=1}^N \left(\frac{(n-1)h_i}{(w_i-w)^n} - \frac{1}{(w_i-w)^{n-1}} \partial_{w_i} \right). \quad (2.125)$$

Two Particular Examples

Let us consider again Eq. (2.122) for a null state at level two. We see that the corresponding descendant field

$$\widehat{L}_{-2} \phi(z) - \frac{3}{2(2h+1)} \widehat{L}_{-1}^2 \phi(z)$$

is a null field where $\widehat{L}_{-1}^2 \phi(z)$ is understood as $(\widehat{L}_{-1}(\widehat{L}_{-1}\phi))(z) = \partial^2 \phi(z)$. Furthermore, this relation implies an expression for the differential operators \mathcal{L}_{-n} acting on correlation functions involving $\phi(z)$, i.e.

$$0 = \left(\mathcal{L}_{-2} - \frac{3}{2(2h+1)} \mathcal{L}_{-1}^2 \right) \langle \phi(w) \phi_1(w_1) \dots \phi_N(w_N) \rangle.$$

From Eq. (2.124), we recall that $\widehat{L}_{-1} \phi(w) = \partial_w \phi(w)$ and therefore \mathcal{L}_{-1} acts as ∂_w . Employing then the definition (2.125) for \mathcal{L}_{-2} , we find

$$0 = \left(\sum_{i=1}^N \left(\frac{h_i}{(w_i - w)^2} - \frac{1}{w_i - w} \partial_{w_i} \right) - \frac{3}{2(2h+1)} \partial_w^2 \right) \langle \phi(w) \phi_1(w_1) \dots \phi_N(w_N) \rangle. \quad (2.126)$$

Working out this differential equation for the example of the two-point function yields

$$\begin{aligned} 0 &= \left(\frac{h}{(w_1 - w)^2} - \frac{1}{w_1 - w} \partial_{w_1} - \frac{3}{2(2h+1)} \partial_{w_1}^2 \right) \frac{d}{(w - w_1)^{2h}} \\ 0 &= \left(h + 2h - \frac{3}{2(2h+1)} 2h(2h+1) \right) \frac{d}{(w - w_1)^{2h+2}}, \end{aligned}$$

and we realise that it is trivially satisfied. However, for the three-point function we will find a non-trivial condition. Recalling the precise form of this correlator

$$\langle \phi(w) \phi_1(w_1) \phi_2(w_2) \rangle = \frac{C_{\phi \phi_1 \phi_2}}{(w - w_1)^{h+h_1-h_2} (w_1 - w_2)^{h_1+h_2-h} (w - w_2)^{h+h_2-h_1}},$$

and inserting it into the differential equation (2.126), after a tedious calculation one obtains the following constraint on the conformal weights $\{h, h_1, h_2\}$:

$$2(2h+1)(h+2h_2-h_1) = 3(h-h_1+h_2)(h-h_1+h_2+1).$$

This expression can be solved for h_2 leading to

$$h_2 = \frac{1}{6} + \frac{h}{3} + h_1 \pm \frac{2}{3} \sqrt{h^2 + 3hh_1 - \frac{1}{2}h + \frac{3}{2}h_1 + \frac{1}{16}}. \quad (2.127)$$

Fusion Rules for Unitary Minimal Models

Next, let us apply Eq. (2.127) to the primary fields $\phi_{(p,q)}$ of the rational models with central charges $c(m)$ studied in Sect. 2.10. In particular, if we choose $h = h_{2,1}(m)$ and $h_1 = h_{p,q}(m)$ then the two solutions for h_2 are precisely $\{h_{p-1,q}(m), h_{p+1,q}(m)\}$. Therefore, at most two of the coefficients $C_{\phi \phi_1 \phi_2}$ of a three-point function will be non-zero. The OPE of $\phi_2 = \phi_{(2,1)}$ with any other primary field $\phi_{(p,q)}$ in a unitary minimal model is then restricted to be of the form

$$[\phi_{(2,1)}] \times [\phi_{(p,q)}] = [\phi_{(p+1,q)}] + [\phi_{(p-1,q)}], \quad (2.128)$$

where $[\phi_{(p,q)}]$ denotes the conformal family descending from $\phi_{(p,q)}$ ². Still, the coefficients $C_{\phi_1\phi_2}$ could be zero, but at most two other conformal families appear on the right-hand side of Eq. (2.128).

This strategy can be generalised to higher level null states. Without detailed derivation, we note the final result that the conformal families in a unitary minimal model form a closed algebra

$$[\phi_{(p_1,q_1)}] \times [\phi_{(p_2,q_2)}] = \sum_{\substack{k=1+|p_1-p_2| \\ k+p_1+p_2 \text{ odd}}}^{p_1+p_2-1} \sum_{\substack{l=1+|q_1-q_2| \\ l+q_1+q_2 \text{ odd}}}^{q_1+q_2-1} [\phi_{(k,l)}] . \quad (2.129)$$

These are the so-called *fusion rules* for the conformal families in the unitary minimal models of the Virasoro algebra.

Let us briefly illustrate these rules for the Ising model, i.e. for $m = 3$. We label the relevant fields $\phi_{(p,q)}$ as

$$\begin{aligned} \phi_{(1,1)} &= 1 , & \phi_{(1,2)} &= \sigma , & \phi_{(1,3)} &= \epsilon , \\ \phi_{(2,3)} &= 1 , & \phi_{(2,2)} &= \sigma , & \phi_{(2,1)} &= \epsilon . \end{aligned}$$

Using the formula above, we then find

$$\begin{aligned} [1] \times [\sigma] &= [\sigma] , & [\epsilon] \times [\epsilon] &= [1] , & [\sigma] \times [\sigma] &= [1] + [\epsilon] , \\ [1] \times [\epsilon] &= [\epsilon] , & [\epsilon] \times [\sigma] &= [\sigma] . \end{aligned}$$

Fusion Algebra

The fusion rules (2.129) for the unitary minimal models of the Virasoro algebra can be generalised to arbitrary RCFTs. In particular, the OPE between conformal families $[\phi_i]$ and $[\phi_j]$ gives rise to the concept of a *Fusion algebra*

$$[\phi_i] \times [\phi_j] = \sum_k N_{ij}^k [\phi_k] \quad (2.130)$$

where $N_{ij}^k \in \mathbb{Z}_0^+$. Furthermore, one finds $N_{ij}^k = 0$ if and only if $C_{ijk} = 0$, and for unitary minimal models of $\text{Vir}_{(h,c)}$, we get $N_{ij}^k \in \{0, 1\}$.

Let us note that the algebra (2.130) is commutative as well as associative and that the vacuum representation $[1]$ containing just the energy–momentum tensor as

² Let us make clear how to interpret Eq. (2.128). This equation means that the OPE between a field in the conformal family of $\phi_{(2,1)}$ and a field in the conformal family of $\phi_{(p,q)}$ involves only fields belonging to the conformal families of $\phi_{(p+1,q)}$ and $\phi_{(p-1,q)}$. However, more work is needed to determine the precise form of the OPE.

well as its descendants is the unit element because $N_{i1}^k = \delta_{ik}$. Commutativity of Eq. (2.130) implies $N_{ij}^k = N_{ji}^k$, and for the consequences of associativity consider

$$\begin{aligned} [\phi_i] \times ([\phi_j] \times [\phi_k]) &= [\phi_i] \times \sum_l N_{jk}^l [\phi_l] = \sum_{l,m} N_{jk}^l N_{il}^m [\phi_m] \\ ([\phi_i] \times [\phi_j]) \times [\phi_k] &= \sum_{l,m} N_{ij}^l N_{lk}^m [\phi_m], \end{aligned}$$

from which we conclude that

$$\boxed{\sum_l N_{kj}^l N_{il}^m = \sum_l N_{ij}^l N_{lk}^m}.$$

Defining finally the matrices $(\bar{N}_i)_{jk} := N_{ij}^k$, we can write this formula as

$$\boxed{\bar{N}_i \bar{N}_k = \bar{N}_k \bar{N}_i}. \quad (2.131)$$

We will come back to these fusion rules in the discussion of one-loop partition functions, where we will find an intriguing relation between the fusion coefficients N_{ij}^k and the so-called modular S -matrix.

2.12 Non-Holomorphic OPE and Crossing Symmetry

In this chapter, so far we have mainly focussed on the chiral sector of two-dimensional conformal field theories. However, for non-chiral fields the structure is very similar and so we can briefly summarise it here.

Two- and Three-Point Functions

In particular, the results for the two- and three-point functions of chiral quasi-primary fields $\phi_i(z)$ carry over directly to non-chiral fields $\phi_i(z, \bar{z})$. The two-point function is determined by the $SL(2, \mathbb{C})/\mathbb{Z}_2 \times SL(2, \mathbb{C})/\mathbb{Z}_2$ conformal symmetry up to a normalisation factor as

$$\langle \phi_1(z_1, \bar{z}_1) \phi_2(z_2, \bar{z}_2) \rangle = \frac{d_{12}}{z_{12}^{h_1+h_2} \bar{z}_{12}^{\bar{h}_1+\bar{h}_2}} \delta_{h_1, h_2} \delta_{\bar{h}_1, \bar{h}_2},$$

where again z_{12} is defined as $z_{12} = z_1 - z_2$ and similarly for \bar{z}_{12} . The three-point function is fixed up to the structure constant C_{123} in the following way:

$$\begin{aligned} \langle \phi_1(z_1, \bar{z}_1) \phi_2(z_2, \bar{z}_2) \phi_3(z_3, \bar{z}_3) \rangle &= \\ &= \frac{C_{123}}{z_{12}^{h_1+h_2-h_3} z_{23}^{h_2+h_3-h_1} z_{13}^{h_1+h_3-h_2} \bar{z}_{12}^{\bar{h}_1+\bar{h}_2-\bar{h}_3} \bar{z}_{23}^{\bar{h}_2+\bar{h}_3-\bar{h}_1} \bar{z}_{13}^{\bar{h}_1+\bar{h}_3-\bar{h}_2}}. \end{aligned}$$

OPE of Primary Fields

The general form of the OPE of two non-chiral quasi-primary fields can be determined following the same steps as for the case of chiral fields studied in Sect. 2.6.3. The OPE takes the form

$$\phi_i(z, \bar{z}) \phi_j(w, \bar{w}) = \sum_P \sum_{\{k, \bar{k}\}} C_{ij}^P \frac{\beta_{ij}^{P, \{k\}} \bar{\beta}_{ij}^{P, \{\bar{k}\}} \phi_p^{(k, \bar{k})}(w, \bar{w})}{(z-w)^{h_i+h_j-h_p-K} (\bar{z}-\bar{w})^{\bar{h}_i+\bar{h}_j-\bar{h}_p-\bar{K}}}, \quad (2.132)$$

where the multi-index $\{k, \bar{k}\}$ labels all the descendant fields

$$\{\hat{L}_{-k_1} \dots \hat{L}_{-k_n} \hat{\bar{L}}_{-\bar{k}_1} \dots \hat{\bar{L}}_{-\bar{k}_n} \phi_p(z, \bar{z})\}$$

in the conformal family of the primary field $\phi_p(z, \bar{z})$. Moreover, we have introduced $K = \sum_i k_i$ and $\bar{K} = \sum_i \bar{k}_i$ as well as the coefficients $\beta_{ij}^{P, \{k\}}$ and $\bar{\beta}_{ij}^{P, \{\bar{k}\}}$. The later govern the coupling of the descendants and depend only on the central charge of the theory as well as on the conformal dimensions of the fields involved³. Therefore, in principle, the only unknown parameters are the structure constants C_{ij}^P among the primary fields.

Four-Point Functions and Crossing Symmetry

However, from the operator algebra point of view there are additional constraints for the structure constants C_{ij}^P coming from Jacobi identities (see also Sect. 3.7). At the level of the OPE, these constraints arise from what is called crossing symmetries. These appear first at the level of four-point functions to which we turn now. Due to the $SL(2, \mathbb{C})/\mathbb{Z}_2 \times \overline{SL}(2, \mathbb{C})/\mathbb{Z}_2$ symmetry, a general four-point function

$$G(\mathbf{z}, \bar{\mathbf{z}}) = \langle \phi_i(z_1, \bar{z}_1) \phi_j(z_2, \bar{z}_2) \phi_l(z_3, \bar{z}_3) \phi_m(z_4, \bar{z}_4) \rangle \quad (2.133)$$

can only depend on the so-called crossing ratios

$$x = \frac{z_{12} z_{34}}{z_{13} z_{24}}, \quad \bar{x} = \frac{\bar{z}_{12} \bar{z}_{34}}{\bar{z}_{13} \bar{z}_{24}}.$$

³ We will compute some of these coefficients in Sect. 3.7, when we discuss the construction of \mathcal{W} algebras.

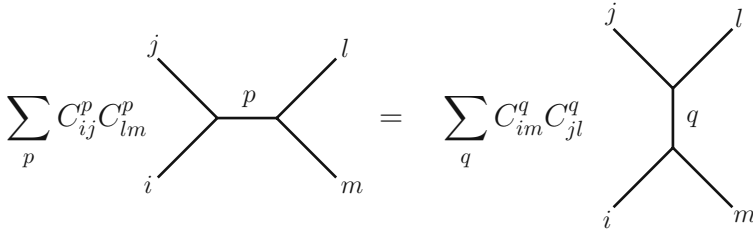

Fig. 2.8 Illustration of the crossing symmetry for four-point functions

This can be made plausible for instance by using the conformal symmetry to map the four points z_i to $z_1 = 0, z_2 = x, z_3 = 1$ and $z_4 = \infty$ and similarly for \bar{z}_i . One can then evaluate the amplitude (2.133) in several different ways.

- First, one can employ the OPE for $\phi_i(z_1, \bar{z}_1)\phi_j(z_2, \bar{z}_2)$ and then the one for $\phi_l(z_3, \bar{z}_3)\phi_m(z_4, \bar{z}_4)$. As a result, the amplitude (2.133) can be expressed as

$$G(\mathbf{z}, \bar{\mathbf{z}}) = \sum_p C_{ij}^p C_{lm}^p \mathcal{F}_{ij}^{lm}(p|x) \bar{\mathcal{F}}_{ij}^{lm}(p|\bar{x}), \tag{2.134}$$

where the contributions of the descendants of the primary field ϕ_p factorise into a holomorphic and an anti-holomorphic piece. These in general quite complicated expressions $\mathcal{F}_{ij}^{lm}(p|x)$ are called conformal blocks and depend only on the conformal dimensions of the primary fields involved and on the central charge of the CFT.

- One can evaluate the four-point function (2.133) also by first using the OPE for $\phi_j(z_2, \bar{z}_2)\phi_l(z_3, \bar{z}_3)$. Effectively this means exchanging $\phi_j(z_2, \bar{z}_2)$ and $\phi_m(z_4, \bar{z}_4)$ which on the level of crossing ratios is achieved by $x \mapsto 1 - x$. The resulting four-point amplitude can now be expressed as

$$G(\mathbf{z}, \bar{\mathbf{z}}) = \sum_p C_{im}^p C_{jl}^p \mathcal{F}_{im}^{jl}(p|1-x) \bar{\mathcal{F}}_{im}^{jl}(p|1-\bar{x}). \tag{2.135}$$

- Similarly, one can first evaluate the OPE $\phi_j(z_2, \bar{z}_2)\phi_m(z_4, \bar{z}_4)$ which leads to the following form of the four-point amplitude:

$$G(\mathbf{z}, \bar{\mathbf{z}}) = x^{-2h_j} \bar{x}^{-2\bar{h}_j} \sum_p C_{il}^p C_{jm}^p \mathcal{F}_{il}^{jm}\left(p\left|\frac{1}{x}\right.\right) \bar{\mathcal{F}}_{il}^{jm}\left(p\left|\frac{1}{\bar{x}}\right.\right). \tag{2.136}$$

Equating the three expressions (2.134), (2.135) and (2.136) for the four-point function gives a number of consistency conditions for the structure constants C_{ij}^p among the primary fields. These so-called crossing symmetry conditions are depicted in Fig. 2.8.

In the boot-strap approach to quantum field theories the hope is that these conditions eventually determine all such structure constants, so that the whole theory is solved. In the case of chiral fields with necessarily (half-)integer conformal dimensions, these crossing symmetry conditions are equivalent to the Jacobi-identity for the corresponding operator algebra.

2.13 Fusing and Braiding Matrices

In the previous section, we have discussed the crossing symmetry of the four-point function of primary fields. For RCFTs a simplification occurs, as there are only a finite number of conformal families which can propagate as intermediate states. This means that the conformal blocks for the three different channels form a finite-dimensional vector space. The crossing symmetry then says that the different classes of conformal blocks are nothing else than three different choices of basis which must be related by linear transformations. We can therefore write

$$\mathcal{F}_{ij}^{kl}(p|x) = \sum_q B \left[\begin{matrix} j & k \\ i & l \end{matrix} \right]_{p,q} \mathcal{F}_{ik}^{jl} \left(q \mid \frac{1}{x} \right). \tag{2.137}$$

The matrices B are called *braiding matrices* and in the example above $\{i, j, k, l\}$ are indices of B while (p, q) denote a particular matrix element. For the second crossing symmetry, one similarly defines the so-called *fusing matrices*

$$\mathcal{F}_{ij}^{kl}(p|x) = \sum_q F \left[\begin{matrix} j & k \\ i & l \end{matrix} \right]_{p,q} \mathcal{F}_{il}^{jk}(q|1-x). \tag{2.138}$$

It is very useful to introduce a graphical notation for these two transformations, which also clarifies the choice of name for them. The braiding matrices defined in Eq. (2.137) are depicted as

$$i \text{---} \begin{matrix} j & k \\ | & | \\ \text{---} & \text{---} \\ p \end{matrix} \text{---} l = \sum_q B_{pq} \quad i \text{---} \begin{matrix} k & j \\ | & | \\ \text{---} & \text{---} \\ q \end{matrix} \text{---} l$$

and the fusing matrices defined in Eq. (2.138) as

$$i \text{---} \begin{matrix} j & k \\ | & | \\ \text{---} & \text{---} \\ p \end{matrix} \text{---} l = \sum_q F_{pq} \quad i \text{---} \begin{matrix} & k \\ & | \\ \text{---} & \text{---} \\ q & j \end{matrix} \text{---} l$$

These matrices satisfy two important identities which can be derived by considering a five-point function and successively applying the braiding, and fusing operations, respectively. Again the origin of these relation is more transparent using the graphical notation. First, the commutativity of the diagram

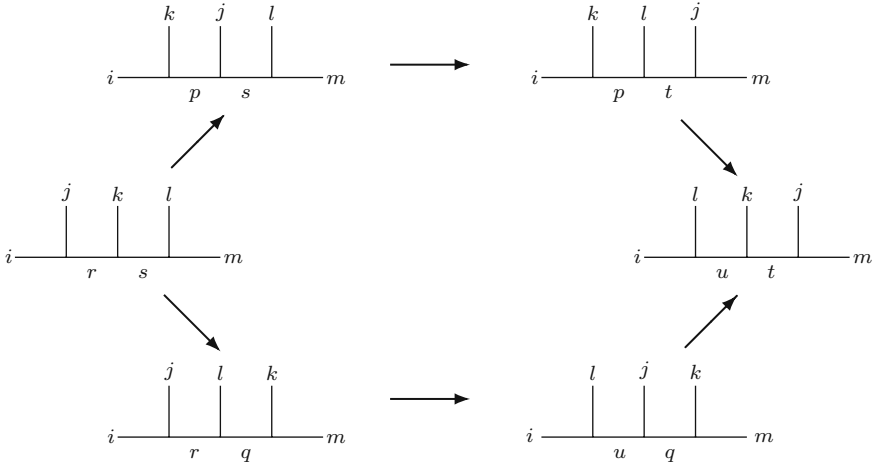

leads to the so-called hexagon identity for the braiding matrices

$$\sum_p B \begin{bmatrix} j & k \\ i & s \end{bmatrix}_{rp} B \begin{bmatrix} j & l \\ p & m \end{bmatrix}_{st} B \begin{bmatrix} k & l \\ i & t \end{bmatrix}_{pu} = \sum_q B \begin{bmatrix} k & l \\ r & m \end{bmatrix}_{sq} B \begin{bmatrix} j & l \\ i & q \end{bmatrix}_{ru} B \begin{bmatrix} j & k \\ u & m \end{bmatrix}_{qt} ,$$

which is very similar to the Yang–Baxter equation arising for integrable models. Similarly, the commutativity of the diagram

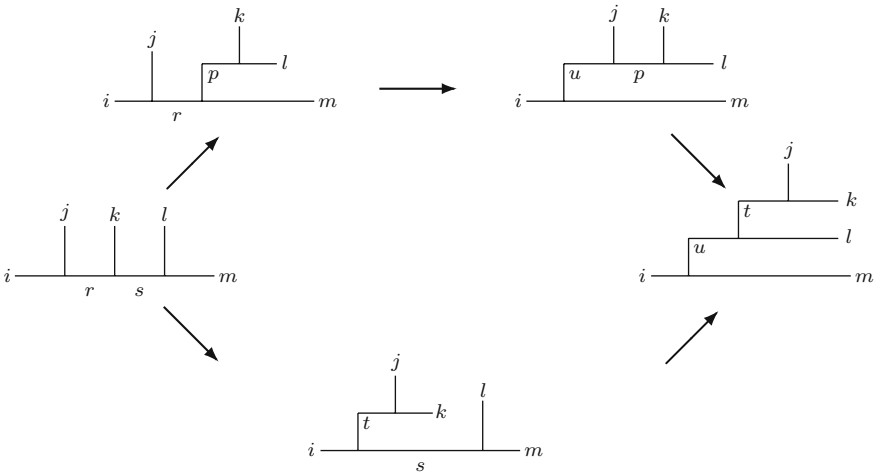

implies a pentagon identity for the fusing matrices

$$F \begin{bmatrix} j & k \\ i & s \end{bmatrix}_{rt} F \begin{bmatrix} t & l \\ i & m \end{bmatrix}_{su} = \sum_p F \begin{bmatrix} k & l \\ r & m \end{bmatrix}_{sp} F \begin{bmatrix} j & p \\ i & m \end{bmatrix}_{ru} F \begin{bmatrix} j & k \\ u & l \end{bmatrix}_{pt} .$$

We will see in Sect. 4.3 that the pentagon identity also plays a very important role in the proof of the so-called Verlinde formula.

Further Reading

1. A. A. Belavin, A. M. Polyakov, and A. B. Zamolodchikov, “Infinite conformal symmetry in two-dimensional quantum field theory,” *Nucl. Phys.* **B241** (1984) 333–380.
2. D. Friedan, E. J. Martinec, and S. H. Shenker, “Conformal invariance, supersymmetry and string theory,” *Nucl. Phys.* **B271** (1986) 93.
3. D. Friedan, Z.-a. Qiu, and S. H. Shenker, “Conformal invariance, unitarity and two-dimensional critical exponents,” *Phys. Rev. Lett.* **52** (1984) 1575–1578.
4. G. W. Moore and N. Seiberg, “Lectures on RCFT,” Presented at Trieste Spring School (1989).
5. G. W. Moore and N. Seiberg, “Polynomial equations for rational conformal field theories,” *Phys. Lett.* **B212** (1988) 451.

Chapter 3

Symmetries of Conformal Field Theories

In the last chapter, we have seen how conformal symmetry can be used as a tool for studying, and in some cases even “solving”, conformal field theories. In particular, we identified the chiral and the anti-chiral sector of a CFT whose structure is severely constrained by the conformal symmetry $\text{Vir} \oplus \overline{\text{Vir}}$. Most notably, for theories with central charges $0 < c < 1$, only a discrete series of unitary CFTs, the so-called unitary minimal models, can exist for which we determined the operator algebra in terms of fusion rules. Let us emphasise that for all these results, we *never* needed a concrete realisation of the CFT!

Therefore, conformal symmetry has far-reaching consequences for a Field Theory and it is worthwhile studying what other symmetries conformal field theories can have.

3.1 Kač–Moody Algebras

We already came across conformal field theories where not only the energy-momentum tensor generates the Virasoro algebra, but also other fields satisfy a symmetry algebra. Indeed, as we have seen on p. 37, currents form a closed algebra called a Kač–Moody algebra.

On general grounds, a Kač–Moody algebra $\hat{\mathfrak{g}}_k$ is defined via the commutation relations

$$[j_m^a, j_n^b] = i \sum_c f^{abc} j_{m+n}^c + k m \delta^{ab} \delta_{m+n,0}, \tag{3.1}$$

where f^{abc} are the structure constants of the Lie algebra \mathfrak{g} and k denotes its central extension called the level of the Kač–Moody algebra $\hat{\mathfrak{g}}_k$. Furthermore, from Eq. (3.1) we see that the zero modes j_0^a of the currents $j^a(z)$ form a finite subalgebra of $\hat{\mathfrak{g}}_k$ which precisely is the Lie algebra \mathfrak{g}

$$[j_0^a, j_0^b] = i \sum_c f^{abc} j_0^c.$$

For a concrete example, let us recall Sect. 2.9.1 where we considered the Kač–Moody algebra of currents expressed in terms of the free boson. In particular, we found a realisation of $\widehat{\mathfrak{su}}(2)_1$ via

$$j(z) = i \partial X(z), \quad j^\pm(z) =: e^{\pm i\sqrt{2}X(z)} : .$$

The usual $\mathfrak{su}(2)$ relations were then recovered via the linear combinations $j^1 = \frac{1}{\sqrt{2}}(j^+ + j^-)$, $j^2 = \frac{1}{\sqrt{2}i}(j^+ - j^-)$ and by $j^3 = j$.

As we have already seen several times, the algebra expressed in terms of the commutation relations of the Laurent modes is equivalent to the operator product expansion of the corresponding fields. Using the usual Laurent expansion of a chiral field with conformal dimension $h = 1$

$$j^a(z) = \sum_{n \in \mathbb{Z}} j_n^a z^{-n-1}, \quad j_n^a = \oint \frac{dz}{2\pi i} z^n j^a(z), \quad (3.2)$$

one finds that the commutation relations (3.1) of the Kač–Moody algebra $\widehat{\mathfrak{g}}_k$ are equivalent to the OPE

$$j^a(z) j^b(w) = \frac{k \delta^{ab}}{(z-w)^2} + \sum_c \frac{if^{abc}}{z-w} j^c(w) + \dots .$$

3.2 The Sugawara Construction

The symmetry algebra of the CFTs studied in the last chapter was the Virasoro algebra generated by the energy–momentum tensor. Now, we want to consider symmetry algebras realised by currents which of course have to be compatible with the Virasoro algebra. This implies there should exist an inherent definition of the energy–momentum tensor such that with respect to $T(z)$, the currents $j^a(z)$ have conformal dimension $h = 1$. This is the subject of the present section.

The Energy–Momentum Tensor

Guided by the example of the free boson, we make the following ansatz for the energy–momentum tensor $T(z)$ ¹:

$$T(z) = \gamma \sum_{a=1}^{\dim \mathfrak{g}} N(j^a j^a)(z),$$

¹ The expression for $T(z)$ can be derived from the action of the corresponding Wess–Zumino–Witten model. However, taking a different point of view, we can also define the CFT via the energy–momentum tensor and in principle also allow for a more general quadratic ansatz for $T(z)$ in terms of the currents.

where γ is some constant which we will determine in the following. By requiring that the j^a are primary fields of conformal dimension $h = 1$, we can write the ansatz above in terms of the Laurent modes as

$$L_m = \gamma \sum_{a=1}^{\dim \mathfrak{g}} \left(\sum_{l \leq -1} j_l^a j_{m-l}^a + \sum_{l > -1} j_{m-l}^a j_l^a \right). \quad (3.3)$$

In order to determine the conformal weight of a primary field, let us then recall Eq. (2.45) from the previous chapter

$$[L_m, \phi_n] = ((h-1)m - n) \phi_{m+n}, \quad (3.4)$$

with ϕ_m the Laurent modes of a chiral primary $\phi(z)$. In order to fix γ by demanding that j^a has conformal weight $h = 1$, we calculate

$$\begin{aligned} & [L_m, j_n^a] \\ &= \gamma \sum_b \left(\sum_{l \leq -1} [j_l^b j_{m-l}^b, j_n^a] + \sum_{l > -1} [j_{m-l}^b j_l^b, j_n^a] \right) \\ &= \gamma \sum_b \left(\sum_{l \leq -1} \left(j_l^b [j_{m-l}^b, j_n^a] + [j_l^b, j_n^a] j_{m-l}^b \right) + \sum_{l > -1} \left(j_{m-l}^b [j_l^b, j_n^a] + [j_{m-l}^b, j_n^a] j_l^b \right) \right) \\ &= -2\gamma n k j_{m+n}^a + \gamma \sum_{b,c} i f^{bac} \sum_{l \leq -1} (j_l^b j_{m+n-l}^c + j_{l+n}^c j_{m-l}^b) \\ &\quad + \gamma \sum_{b,c} i f^{bac} \sum_{l > -1} (j_{m+n-l}^c j_l^b + j_{m-l}^b j_{l+n}^c). \end{aligned}$$

Because of the anti-symmetry of the structure constants of a Lie algebra, i.e. $f^{bac} = -f^{cab}$, we have $\sum_{b,c} f^{bac} j_m^b j_n^c = -\sum_{b,c} f^{bac} j_m^c j_n^b$ and so we can write for the last two terms in the expression above

$$\begin{aligned} \sum_{l \leq -1} (j_l^b j_{m+n-l}^c - j_{l+n}^c j_{m-l}^b) &= \sum_{l \leq -1} j_l^b j_{m+n-l}^c - \sum_{l \leq -1+n} j_n^b j_{m+n-l}^c = -\sum_{l=0}^{n-1} j_l^b j_{m+n-l}^c, \\ \sum_{l > -1} (j_{m+n-l}^c j_l^b - j_{m-l}^c j_{l+n}^b) &= \sum_{l > -1} j_{m+n-l}^c j_l^b - \sum_{l > -1+n} j_{m+n-l}^c j_l^b = +\sum_{l=0}^{n-1} j_{m+n-l}^c j_l^b, \end{aligned}$$

where we assumed without loss of generality that $n > 0$. Using these expressions, the commutator $[L_m, j_n^a]$ above becomes

$$\begin{aligned}
[L_m, j_n^a] &= -2\gamma n k j_{m+n}^a - \gamma \sum_{b,c} i f^{bac} \sum_{l=0}^{n-1} [j_l^b, j_{m+n-l}^c] \\
&= -2\gamma n k j_{m+n}^a - \gamma \sum_{b,c} i f^{bac} \sum_{l=0}^{n-1} \sum_d i f^{bcd} j_{m+n}^d \\
&= -2\gamma n k j_{m+n}^a + \gamma n \sum_{b,c,d} f^{bac} f^{bcd} j_{m+n}^d .
\end{aligned}$$

For the structure constants f^{abc} , let us note the following relation:

$$\sum_{b,c} f^{bac} f^{bcd} = -2 C_{\mathfrak{g}} \delta^{ad} , \quad (3.5)$$

where $C_{\mathfrak{g}}$ is the dual Coxeter number of the Lie algebra \mathfrak{g} . For $\mathfrak{su}(N)$, which we will mostly consider, we have for instance $C_{\mathfrak{g}} = N$. Using Eq. (3.5), we can express the commutator above as

$$[L_m, j_n^a] = -2\gamma n (k + C_{\mathfrak{g}}) j_{m+n}^a .$$

Demanding that the current $j^a(z)$ has conformal weight $h = 1$ and comparing with Eq. (3.4), we find $\gamma^{-1} = 2(k + C_{\mathfrak{g}})$. We thus have obtained the following expression which is the so-called Sugawara energy–momentum tensor of a CFT given by the current algebra $\hat{\mathfrak{g}}_k$:

$$\boxed{T(z) = \frac{1}{2(k + C_{\mathfrak{g}})} \sum_{a=1}^{\dim \mathfrak{g}} N(j^a j^a)(z)} . \quad (3.6)$$

The Central Charge

Next, we will determine the central charge of the conformal field theory defined by the energy–momentum tensor (3.6). Let us start by recalling from Sect. 2.7 that

$$L_{-2} |0\rangle = \gamma \sum_a j_{-1}^a j_{-1}^a |0\rangle \quad \text{and} \quad j_0^a |0\rangle = 0 ,$$

where in favour of readability we have not written out the constant γ . Along the lines we have followed already several times, we calculate

$$\begin{aligned}
\frac{c}{2} &= \langle 0 | L_{+2} L_{-2} | 0 \rangle \\
&= \gamma^2 \sum_{a,b} \langle 0 | j_1^b j_1^b j_{-1}^a j_{-1}^a | 0 \rangle \\
&= \gamma^2 \sum_{a,b} \left(\langle 0 | j_1^b [j_1^b, j_{-1}^a] j_{-1}^a | 0 \rangle + \langle 0 | [j_1^b, j_{-1}^a] [j_1^b, j_{-1}^a] | 0 \rangle \right) \\
&= \gamma^2 \sum_{a,b} \left(i \sum_c f^{bac} \langle 0 | j_1^b [j_0^c, j_{-1}^a] | 0 \rangle + k \langle 0 | j_1^b j_{-1}^a | 0 \rangle \delta^{ba} + k^2 \delta^{ba} \right) \\
&= \gamma^2 \sum_{a,b} \left(- \sum_{c,d} f^{bac} f^{cad} \langle 0 | [j_1^b, j_{-1}^d] | 0 \rangle + 2k^2 \delta^{ba} \right) \\
&= \gamma^2 \sum_{a,b} \left(- \sum_{c,d} f^{bac} f^{cad} k \delta^{bd} + 2k^2 \delta^{ba} \right) \\
&= \gamma^2 \left(\sum_d 2C_{\mathfrak{g}} k + \sum_a 2k^2 \right) = \frac{k \dim \mathfrak{g}}{2(k + C_{\mathfrak{g}})},
\end{aligned}$$

where we employed Eq. (3.5). Therefore, we can conclude that

The central charge of the conformal field theory defined by the current algebra $\widehat{\mathfrak{g}}_k$ with respect to the Sugawara energy–momentum tensor is

$$c = \frac{k \dim \mathfrak{g}}{k + C_{\mathfrak{g}}}. \quad (3.7)$$

Remarks

- For $\widehat{\mathfrak{su}}(2)_k$, the dimension of the corresponding Lie algebra is $\dim \mathfrak{g} = 3$ and the dual Coxeter number reads $C_{\mathfrak{g}} = 2$ which leads to $c = \frac{3k}{k+2}$. The case $k = 1$ gives $c = 1$, which can be realised via the CFT of the free boson.
- For $\widehat{\mathfrak{su}}(3)_k$, we have $\dim \mathfrak{g} = 8$ and $C_{\mathfrak{g}} = 3$ leading to $c = \frac{8k}{k+3}$. The case $k = 1$ has central charge $c = 2$ which reflects the fact that $\widehat{\mathfrak{su}}(3)_1$ can be realised by two free bosons compactified on the root lattice of $\mathfrak{su}(3)$.²
- In general, for $\widehat{\mathfrak{su}}(N)_k$ we find $\dim \mathfrak{g} = N^2 - 1$ and $C_{\mathfrak{g}} = N$. Therefore, the central charge is given by $c = \frac{(N^2-1)k}{k+N}$. For the case $k = 1$, we have $c = N - 1$ which can be realised by $(N - 1)$ free bosons.

² The $(N - 1)$ -dimensional root lattice of $\mathfrak{su}(N)$ is spanned by the simple roots of the algebra. For the special case when the bosons are compactified on such root lattices, the symmetry among the currents is enhanced to $\widehat{\mathfrak{su}}(N)_1$.

- For the A-D-E Lie algebras $\mathfrak{su}(N)$, $\mathfrak{so}(2N)$, \mathfrak{e}_6 , \mathfrak{e}_7 and \mathfrak{e}_8 , the corresponding current algebra $\hat{\mathfrak{g}}_1$ at level one naturally appears in the heterotic string. Indeed, compactifying the heterotic string in the bosonic left-moving sector on the root lattice of the Lie algebra \mathfrak{g} gives the free-field realisation of $\hat{\mathfrak{g}}_1$ and leads to massless spin 1 string excitations transforming in the adjoint representation of the Lie algebra \mathfrak{g} . From the space–time point of view, these are nothing else than non-abelian gauge fields in the gauge group G .

3.3 Highest Weight Representations of $\widehat{\mathfrak{su}}(2)_k$

Analogously to the Virasoro algebra, let us now study the representation theory of Kač–Moody algebras. However, we will not present a rigorous analysis but only illustrate the main features at the example of the most common $\widehat{\mathfrak{su}}(2)_k$ algebra. Implementing more structure from the theory of Lie algebras, the generalisation to other simple Kač–Moody algebras is fairly straightforward.

Highest Weight Representations

Let us recall the current algebra (3.1) but use instead of f^{abc} the usual structure constants $\sqrt{2} \epsilon^{abc}$ of the Lie algebra $\mathfrak{su}(2)$ where ϵ^{abc} is the anti-symmetric tensor

$$[j_m^a, j_n^b] = i \sqrt{2} \sum_c \epsilon^{abc} j_{m+n}^c + k m \delta_{m+n,0} \delta^{ab}. \quad (3.8)$$

Next, we define the raising and lowering operators

$$\hat{j}_m^3 = \frac{1}{\sqrt{2}} j_m^3, \quad \hat{j}_m^\pm = \frac{1}{\sqrt{2}} (j_m^1 \pm i j_m^2)$$

to rewrite the commutation relations (3.8). The non-trivial commutators in the new basis read

$$[\hat{j}_m^3, \hat{j}_n^3] = \frac{m k}{2} \delta_{m+n,0}, \quad [\hat{j}_m^3, \hat{j}_n^\pm] = \pm \hat{j}_{m+n}^\pm, \quad [\hat{j}_m^+, \hat{j}_n^-] = k m \delta_{m+n,0} + 2 \hat{j}_{m+n}^3.$$

Similar to Sect. 2.10, we can now define a highest weight state $|h, q\rangle$ via the requirements

$$\begin{aligned} \hat{j}_n^3 |h, q\rangle &= \hat{j}_n^\pm |h, q\rangle = 0 \quad \text{for } n > 0, \\ \hat{j}_0^3 |h, q\rangle &= \frac{q}{2} |h, q\rangle, \\ \hat{j}_0^+ |h, q\rangle &= 0. \end{aligned} \quad (3.9)$$

In the following, we will study the properties of the highest weight representations in more detail.

1. For each primary field with conformal dimension h , the corresponding highest weight state $|h\rangle$ forms a finite-dimensional representation of the Lie algebra $\mathfrak{su}(2)$ which is the subalgebra of the zero modes. We thus define

$$|h, q_\alpha\rangle := (\hat{J}_0^-)^\alpha |h, q\rangle.$$

As is known from Quantum Mechanics, for a spin $\frac{l}{2}$ representation of $\mathfrak{su}(2)$ with $l = 0, 1, 2, \dots$ we have $\alpha = 0, 1, 2, \dots, l$ as well as $q = l$ and $q_\alpha = l - 2\alpha$. We therefore conclude that

The eigenvalues of $2\hat{J}_0^3$ are integer, that is, $q \in \mathbb{Z}$.

2. The zero modes \hat{J}_0^\pm and \hat{J}_0^3 form only one particular $\mathfrak{su}(2)$ subalgebra of $\widehat{\mathfrak{su}}(2)_k$. There exist other $\mathfrak{su}(2)$ subalgebras which can be used to further constrain highest weight representations of $\widehat{\mathfrak{su}}(2)_k$. To investigate this point, let us define

$$\tilde{j}^+ = \frac{1}{\sqrt{2}} (j_{-1}^1 + i j_{-1}^2), \quad \tilde{j}^- = \frac{1}{\sqrt{2}} (j_{+1}^1 - i j_{+1}^2), \quad \tilde{j}^3 = \frac{1}{\sqrt{2}} j_0^3 - \frac{k}{2},$$

which satisfy an $\widetilde{\mathfrak{su}}(2)$ algebra. Indeed, using Eq. (3.8) one observes that these operators obey the commutation relations

$$[\tilde{j}^3, \tilde{j}^3] = 0, \quad [\tilde{j}^3, \tilde{j}^\pm] = \pm \tilde{j}^\pm, \quad [\tilde{j}^+, \tilde{j}^-] = 2\tilde{j}^3.$$

Therefore, each unitary representation of $\widehat{\mathfrak{su}}(2)_k$ must be a (reducible) unitary representation not only of $\widehat{\mathfrak{su}}(2)$ but also of $\widetilde{\mathfrak{su}}(2)$. Similarly as above, $2\tilde{j}^3$ then has integer eigenvalues and since we know already that $2\hat{J}_0^3$ has integer eigenvalues, it follows from the definition of \tilde{j}^3 that $k \in \mathbb{Z}$.

To summarise, unitary highest weight representations of $\widehat{\mathfrak{su}}(2)_k$ can exist only for $k \in \mathbb{Z}$.

3. Let us now consider the L_0 eigenvalue of $|h, q_\alpha\rangle$ which is the conformal weight or the (chiral) ground state energy. Using for instance Eq. (3.3), the Laurent mode L_0 of the energy–momentum tensor (3.6) is determined to be of the form

$$L_0 = \frac{1}{2(k+2)} \sum_{a=1}^3 \left(\sum_{l \leq -1} j_{+l}^a j_{-l}^a + \sum_{l > -1} j_{-l}^a j_{+l}^a \right).$$

Here, we also employed that $C_{\mathfrak{g}} = 2$ and $\dim \mathfrak{g} = 3$ for $\mathfrak{su}(2)$. Computing the action of L_0 on a highest weight state $|h, q_\alpha\rangle$ we find

$$\begin{aligned}
L_0 |h, q_\alpha\rangle &= \frac{1}{2(k+2)} \sum_{a=1}^3 j_0^a j_0^a |h, q_\alpha\rangle \\
&= \frac{1}{k+2} \sum_{a=1}^3 \hat{j}_0^a \hat{j}_0^a |h, q_\alpha\rangle = \frac{l(l+2)}{4(k+2)} |h, q_\alpha\rangle
\end{aligned} \tag{3.10}$$

for $|h, q_\alpha\rangle$ a spin $\frac{l}{2}$ representation of $\widehat{\mathfrak{su}}(2)$. Here, we observed that $\sum_a \hat{j}_0^a \hat{j}_0^a$ is the Casimir operator of $\widehat{\mathfrak{su}}(2)$ with eigenvalue $\frac{l(l+2)}{4}$.

In conclusion, because $L_0 |h, q_\alpha\rangle = h |h, q_\alpha\rangle$, we have found that the conformal dimension of a highest weight state $|h, q_\alpha\rangle$ in the spin $\frac{l}{2}$ representation has to be

$$h = \frac{l(l+2)}{4(k+2)}. \tag{3.11}$$

4. Let us finally take the highest \hat{j}_0^3 state in $|h, q_\alpha\rangle$ which is $|h, l\rangle$. It is in a spin $\frac{l}{2}$ representation of the ground state and we have $\hat{j}_0^+ |h, l\rangle = 0$. Computing the norm of $\tilde{j}^+ |h, l\rangle$ we obtain

$$\begin{aligned}
\langle h, l | \tilde{j}^- \tilde{j}^+ |h, l\rangle &= \langle h, l | [\tilde{j}^-, \tilde{j}^+] |h, l\rangle \\
&= \langle h, l | -2 \tilde{j}^3 |h, l\rangle \\
&= -2 \langle h, l | \hat{j}_0^3 - \frac{k}{2} |h, l\rangle \\
&= -l + k,
\end{aligned}$$

where we employed Eq. (2.31) to observe that the hermitian conjugate of \tilde{j}^+ is \tilde{j}^- . Because in a unitary representation the norm of all states has to be non-negative, we have to require that $0 \leq l \leq k$.

To summarise, unitary highest weight representations of $\widehat{\mathfrak{su}}(2)_k$ are only allowed for $0 \leq l \leq k$ with $k \in \mathbb{Z}^+$.

Subalgebras of $\widehat{\mathfrak{su}}(2)_k$ and Generating Functions

In the last paragraph, we have studied two particular subalgebras of the $\widehat{\mathfrak{su}}(2)_k$ Kač–Moody algebra. However, one can even find an infinite set of $\tilde{\mathfrak{su}}(2)_{(n)} \subset \widehat{\mathfrak{su}}(2)_k$ subalgebras defined by the following operators:

$$\begin{aligned} \tilde{j}_{(n)}^+ &= \frac{1}{\sqrt{2}} (j_{-n}^1 + i j_{-n}^2), \\ \tilde{j}_{(n)}^- &= \frac{1}{\sqrt{2}} (j_{+n}^1 - i j_{+n}^2), \\ \tilde{j}_{(n)}^3 &= \frac{1}{\sqrt{2}} j_0^3 - \frac{nk}{2}, \end{aligned}$$

with $n \in \mathbb{Z}$. Using these, one can deduce a lot of information about highest weight representations of $\widehat{\mathfrak{su}}(2)_k$. We explain this at the example of $\widehat{\mathfrak{su}}(2)_1$ which is illustrated in Fig. 3.1.

- We start with the highest weight state $|h, q\rangle = |0, 0\rangle$ transforming in the singlet representation of the zero mode $\widehat{\mathfrak{su}}(2)$ algebra, i.e. $\hat{j}_0^3 |0, 0\rangle = 0$.
- Relative to the $\widehat{\mathfrak{su}}(2)_{(1)}$ algebra, this state has $\tilde{j}_{(1)}^3$ eigenvalue $-1/2$ which we infer from the definition of $\tilde{j}_{(1)}^3$. Therefore, $|0, 0\rangle$ must be in the spin $\frac{1}{2}$ representation of $\widehat{\mathfrak{su}}(2)_{(1)}$. Working out the definition of $\tilde{j}_{(1)}^-$, we see that $\tilde{j}_{(1)}^- |0, 0\rangle = 0$ and so

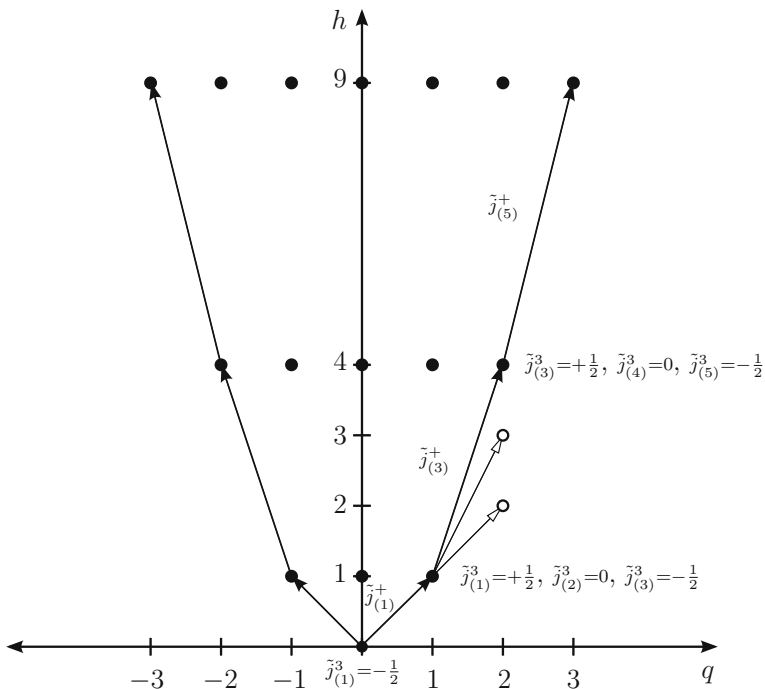

Fig. 3.1 Highest weight representations of $\widehat{\mathfrak{su}}(2)_1$. The *arrows* represent various raising operators, and for some representations the $\tilde{j}_{(n)}^3$ eigenvalues can be found. The *empty dots* indicate that the action of some $\tilde{j}_{(n)}^+$ vanishes

there is precisely one other state in this representation, namely $\tilde{j}_{(1)}^+|0, 0\rangle$, which has $(h, q) = (1, 1)$ in our notation from Eq. (3.9).

- We can continue with this type of arguments and observe that with respect to $\widehat{\mathfrak{su}}(2)_{(2)}$, the state $\tilde{j}_{(1)}^+|0, 0\rangle$ is a singlet representation and with respect to $\widehat{\mathfrak{su}}(2)_{(3)}$ it is in a spin $\frac{1}{2}$ representation. Therefore, there exists one other state in the $\widehat{\mathfrak{su}}(2)_{(3)}$ representation, namely $\tilde{j}_{(3)}^+ \tilde{j}_{(1)}^+|0, 0\rangle$, with $(h, q) = (4, 2)$.
- This structure continues in steps of two so that on the boundary of the diagram in the (h, q) -plane, there are states $(h, q) = (m^2, m)$ with $m \in \mathbb{Z}$.

In the case of $\widehat{\mathfrak{su}}(2)_1$, it turns out that knowing just the states on the boundary in the (h, q) -plane is sufficient for extracting the degeneracies of states on each level (h, q) . In particular, at the end of Sect. 2.9.1, we have seen that $\widehat{\mathfrak{su}}(2)_1$ can be realised in terms of a free boson $X(z, \bar{z})$ via the currents

$$\begin{aligned} j(z) &= i \partial X(z, \bar{z}) & (h, q) &= (1, 0) , \\ V_{\pm\sqrt{2}} &=: e^{\pm i\sqrt{2}X} : & (h, q) &= (1, \pm 1) , \end{aligned}$$

where we have also written down the conformal weight h and the $\hat{j}_0^3 = \frac{1}{\sqrt{2}} j_0$ eigenvalue obtained for instance from the commutator $[j_0, V_{\pm\sqrt{2}}]$. However, we can construct additional bosonic fields as

$$V_{\pm\sqrt{2}m} =: e^{\pm i\sqrt{2}mX} : \quad (h, q) = (m^2, \pm m) , \quad (3.12)$$

where $m \in \mathbb{Z}$. By comparing with Fig. 3.1, we observe that the values (h, q) of Eq. (3.12) describe the boundary of the diagram in the (h, q) -plane. In fact, this equivalence between the fields (3.12) and $\widehat{\mathfrak{su}}(2)_1$ states with $(h, q) = (m^2, m)$ can be proven. We will come back to the vertex operators (3.12) and explain their relation to the free boson compactified on a circle of radius $R = \sqrt{2}$ in Sect. 4.2.3.

Since we are familiar with the creation operators j_{-n} of the free boson theory, we know how to construct the Hilbert space on each state $|m^2, m\rangle$ with $m \in \mathbb{Z}$. As it turns out, the generating function for the degeneracy of states built upon the $l = q = 0$ highest weight representation of $\widehat{\mathfrak{su}}(2)_1$ can be written as

$$\mathcal{Z}_{0,1}(q) = \frac{1}{\prod_{n=1}^{\infty} (1 - q^n)} \sum_{m \in \mathbb{Z}} q^{m^2} , \quad (3.13)$$

where q keeps track of the L_0 eigenvalues h . Unfortunately, there is a clash between two common notations so let us emphasise that q in Eq. (3.13) is not to be confused with the $2\hat{j}_0^3$ eigenvalue q . The prefactor in Eq. (3.13) is the result for one free boson stated in Eq. (2.98), and the sum includes the states on the boundary $(h, q) = (m^2, m)$. For the $\frac{l}{2} = \frac{1}{2}$ highest weight representations, one finds similarly

$$\mathcal{Z}_{1,1}(q) = \frac{1}{\prod_{n=1}^{\infty} (1 - q^n)} \sum_{m \in \mathbb{Z}} q^{(m+\frac{1}{2})^2} . \tag{3.14}$$

We will come back to these expressions in Chap. 4 and explain their meaning and notation in more detail.

Remark

The structure of the highest weight representations of $\widehat{\mathfrak{su}}(2)_1$ generalises to higher levels k . For these cases, one does not have a simple realisation in terms of one free boson but using the infinite set of $\mathfrak{su}(2)_{(m)}$ subalgebras, one can deduce the states on the boundary of the HWRs in the (h, q) -plane. On top of each of these states, one finds only a finite set of different generating functions $C_{l,m}^{(k)}(q)$. It turns out that the complete generating function can be written as

$$\mathcal{Z}_{1,k}(q) = \sum_{\substack{m=-k+1 \\ l+m=0 \pmod{2}}}^k C_{l,m}^{(k)}(q) \Theta_{m,k}(q) ,$$

with

$$\Theta_{m,k}(q) = \sum_{n \in \mathbb{Z} + \frac{m}{2k}} q^{kn^2} .$$

We will discuss these expressions and in particular the so-called string functions $C_{l,m}^{(k)}(q)$ in more detail in Sect. 4.6.

3.4 The $\widehat{\mathfrak{so}}(N)_1$ Current Algebra

Due to their ubiquity in superstring models, let us briefly discuss the $\widehat{\mathfrak{so}}(N)_1$ current algebra. This algebra can be realised by N real free fermions ψ^i transforming in the vector representation of $SO(N)$, for which we have the usual operator product expansion

$$\psi^i(z) \psi^j(w) = \frac{\delta^{ij}}{z - w} + \dots . \tag{3.15}$$

In analogy to the example of two real fermions studied in Sect. 2.9.2, we construct the currents for the present theory as

$$j^a(z) = \frac{1}{2} N (\psi^i t_{ij}^a \psi^j) , \tag{3.16}$$

where $(t^a)_{ij}$ with $a = 1, \dots, \frac{N(N-1)}{2}$ are the representation matrices corresponding to the vector representation of $SO(N)$, and a sum over i, j is understood. Note that the prefactor has been fixed by demanding that the currents satisfy the Kač–Moody algebra (3.1).

We will now compute the level k of this current algebra. The Laurent modes of $j^a(z)$ can be determined with the help of Eq. (2.110) and read

$$j_m^a = \frac{1}{2} \left(- \sum_{s > -\frac{1}{2}} \psi_{m-s}^i t_{ij}^a \psi_s^j + \sum_{s \leq -\frac{1}{2}} \psi_s^j t_{ij}^a \psi_{m-s}^i \right),$$

from which we compute the action of j_{-1}^a and j_{+1}^a on the vacuum as

$$j_{-1}^a |0\rangle = \frac{1}{2} \psi_{-\frac{1}{2}}^j t_{ij}^a \psi_{-\frac{1}{2}}^i |0\rangle, \quad \langle 0| j_{+1}^a = -\frac{1}{2} \langle 0| \psi_{\frac{1}{2}}^i t_{ij}^a \psi_{\frac{1}{2}}^j.$$

Let us mention that the OPE (3.15) implies the usual anti-commutation relation $\{\psi_r^i, \psi_s^j\} = \delta^{ij} \delta_{r,-s}$ for the Laurent modes ψ_r^i and so we can calculate

$$\begin{aligned} \langle 0| j_{+1}^a j_{-1}^a |0\rangle &= -\frac{1}{4} \langle 0| \psi_{\frac{1}{2}}^i t_{ij}^a \psi_{\frac{1}{2}}^j \psi_{-\frac{1}{2}}^k t_{lk}^a \psi_{-\frac{1}{2}}^l |0\rangle \\ &= -\frac{1}{4} t_{ij}^a t_{lk}^a (\langle 0| \psi_{\frac{1}{2}}^i \delta^{jk} \psi_{-\frac{1}{2}}^l |0\rangle - \langle 0| \{\psi_{\frac{1}{2}}^i, \psi_{-\frac{1}{2}}^k\} \{\psi_{\frac{1}{2}}^j, \psi_{-\frac{1}{2}}^l\} |0\rangle) \\ &= -\frac{1}{4} t_{ij}^a t_{lk}^a (\delta^{jk} \delta^{il} - \delta^{ik} \delta^{jl}) = \frac{1}{2} \text{Tr} (t^a)^2 \\ &= +1, \end{aligned}$$

where we implicitly summed over repeated indices and used $\text{Tr} (t^a)^2 = 2$ for $SO(N)$ representation matrices. Recalling the Kač–Moody algebra (3.1), we see that the left-hand side of the expression above is equal to k which implies $k = 1$ for the level of the current algebra given by the OPE (3.15).

Using our formula (3.7) with $k = 1$, $\dim \mathfrak{g} = \frac{1}{2} N(N-1)$ and $C_{\mathfrak{g}} = N-2$, we find for the central charge that $c = \frac{N}{2}$. In summary,

The current algebra constructed out of N free real fermions transforming in the vector representation of $SO(N)$ satisfies the Kač–Moody algebra $\widehat{\mathfrak{so}}(N)_1$ with $c = \frac{N}{2}$.

Note that the representation theory of $\widehat{\mathfrak{so}}(N)_1$ can be traced back to the representation theory of N free fermions which we will discuss in more detail in Sect. 4.2.4.

3.5 The Knizhnik–Zamolodchikov Equation

Analogous to the differential equations to be satisfied for correlation functions of Virasoro primary fields due to null states, the correlation functions of Kač–Moody primaries have to satisfy a first-order differential equation. In this section, we will derive this so-called Knizhnik–Zamolodchikov equation.

Kaç–Moody Primary Fields

To start with, let us define Kač–Moody primary fields. In Chap. 2, we have studied the conformal symmetry generated by the energy–momentum tensor and we identified (Virasoro) primary fields transforming in a distinguished way under the conformal symmetry. Since now we are studying Kač–Moody symmetries generated by currents, we can define primary fields with respect to the Kač–Moody currents.

Definition 1. A Kač–Moody (chiral) primary field transforming in a representation R of a group G is characterised by the OPE

$$j^a(z) \phi_R^r(w) = \frac{1}{z-w} \sum_s (t_R^a)_s^r \phi_R^s(w) + \dots, \quad (3.17)$$

where $j^a(z)$ are currents generating the group G and t_R^a are the corresponding representation matrices.

Let us remark that here we have written out the components ϕ_R^r of the representation ϕ_R explicitly; however, we will also employ the notation $t_R^a \phi_R$ where a matrix product is understood. Furthermore, because the Sugawara energy–momentum tensor is constructed out of Kač–Moody currents, we expect a Kač–Moody primary field also to be a Virasoro primary, but the reverse is not true in general.

Ward Identity for Kač–Moody Symmetries

After having given the definition of a Kač–Moody primary field, we will now determine the Ward identities for the Kač–Moody symmetry. Similar to the conformal Ward identity (2.48) describing the behaviour of correlation functions under conformal symmetry transformations, the Kač–Moody Ward identity describes its behaviour under the Kač–Moody symmetry. In analogy to Eq. (2.35), we observe that under infinitesimal Kač–Moody transformations described by a function $\epsilon^a(z) \ll 1$, a field $\phi(w)$ changes as

$$\delta_\epsilon \phi(w) = \oint_{C(w)} \frac{dz}{2\pi i} \sum_a j^a(z) \epsilon^a(z) \phi(w). \quad (3.18)$$

Next, we compute the variation of a correlation function involving N primary fields. Using the formulas above, we find

$$\begin{aligned}
& \delta_\epsilon \langle \phi_{R_1}(w_1, \bar{w}_1) \dots \phi_{R_N}(w_N, \bar{w}_N) \rangle \\
&= \oint_{\mathcal{C}(w_1, \dots, w_N)} \frac{dz}{2\pi i} \sum_a \epsilon^a(z) \langle j^a(z) \phi_{R_1}(w_1, \bar{w}_1) \dots \phi_{R_N}(w_N, \bar{w}_N) \rangle \\
&= \sum_{i=1}^N \oint_{\mathcal{C}(w_i)} \frac{dz}{2\pi i} \sum_a \epsilon^a(z) \langle \phi_{R_1}(w_1, \bar{w}_1) \dots (j^a(z) \phi_{R_i}(w_i, \bar{w}_i)) \dots \phi_{R_N}(w_N, \bar{w}_N) \rangle \\
&= \sum_{i=1}^N \oint_{\mathcal{C}(w_i)} \frac{dz}{2\pi i} \sum_a \epsilon^a(z) \frac{t_{R_i}^a}{z - w_i} \langle \phi_{R_1}(w_1, \bar{w}_1) \dots \phi_{R_N}(w_N, \bar{w}_N) \rangle,
\end{aligned}$$

where we employed the deformation of contour integrals illustrated in Fig. 2.5 and it is understood that $t_{R_i}^a$ only acts on ϕ_{R_i} . Since the variations $\epsilon^a(z)$ are arbitrary, we obtain from the second and last line of this expression the Ward identity for the Kač–Moody symmetry

$$\boxed{
\begin{aligned}
& \langle j^a(z) \phi_{R_1}(w_1, \bar{w}_1) \dots \phi_{R_N}(w_N, \bar{w}_N) \rangle \\
&= \sum_{i=1}^N \frac{t_{R_i}^a}{z - w_i} \langle \phi_{R_1}(w_1, \bar{w}_1) \dots \phi_{R_N}(w_N, \bar{w}_N) \rangle.
\end{aligned}
}$$

Kaç–Moody Descendant Fields

In this paragraph, let us cover some structure needed for the following. First, we recall Eq. (2.123) for a Virasoro descendant field

$$\widehat{L}_{-n} \phi(w) = \oint \frac{dz}{2\pi i} \frac{1}{(z-w)^{n-1}} T(z) \phi(w),$$

together with our results from Chap. 2 for the relation between states and fields

$$L_{-1} |\phi\rangle \stackrel{(2.74)}{\longleftrightarrow} \partial\phi(w) \stackrel{(2.124)}{=} \widehat{L}_{-1} \phi(w). \quad (3.19)$$

In the same way as the Virasoro descendants are constructed, we define the descendant fields for the Kač–Moody symmetry as

$$\begin{aligned}
j^a(z) \phi_R(w) &= \sum_{n \geq 0} (z-w)^{n-1} (\widehat{j}_{-n}^a \phi_R)(w), \\
(\widehat{j}_{-n}^a \phi_R)(w) &= \oint \frac{dz}{2\pi i} \frac{1}{(z-w)^n} j^a(z) \phi_R(w).
\end{aligned} \quad (3.20)$$

Using the Laurent expansion (3.2), we can compute the following expression:

$$\lim_{w \rightarrow 0} (\widehat{j}_{-n}^a \phi_R)(w) |0\rangle = \oint \frac{dz}{2\pi i} \frac{1}{z^n} j^a(z) |\phi_R\rangle = j_{-n}^a |\phi_R\rangle, \quad (3.21)$$

where we employed the definition of asymptotic states (2.28). From Eq. (3.21) we can then identify

$$j_{-1}^a |\phi_R\rangle \longleftrightarrow \widehat{j}_{-1}^a \phi_R(z). \quad (3.22)$$

Finally, let us employ relation (3.21) and the OPE (3.18) to compute the action of j_0^a on a state $|\phi\rangle$ to be of the following form:

$$\begin{aligned} j_0^a |\phi_R\rangle &= \lim_{w \rightarrow 0} \oint \frac{dz}{2\pi i} j^a(z) \phi_R(w) |0\rangle \\ &= \lim_{w \rightarrow 0} \oint \frac{dz}{2\pi i} \left(\frac{1}{z-w} t_R^a \phi_R(w) + \dots \right) |0\rangle = t_R^a |\phi_R\rangle. \end{aligned} \quad (3.23)$$

Derivation of the Knizhnik–Zamolodchikov Equation

We will now derive the Knizhnik–Zamolodchikov equation. To do so, we determine the L_{-1} Laurent mode of the Sugawara energy–momentum tensor as

$$L_{-1} = \frac{1}{2(k + C_{\mathfrak{g}})} \sum_a \left(\sum_{l \leq -1} j_l^a j_{-1-l}^a + \sum_{l > -1} j_{-1-l}^a j_l^a \right),$$

and for its action on a highest weight state $|\phi_R^r\rangle$ in the representation R we compute

$$\begin{aligned} L_{-1} |\phi_R^r\rangle &= \frac{1}{2(k + C_{\mathfrak{g}})} \sum_a \left(\sum_{l \leq -1} j_l^a j_{-1-l}^a + \sum_{l > -1} j_{-1-l}^a j_l^a \right) |\phi_R^r\rangle \\ &= \frac{1}{2(k + C_{\mathfrak{g}})} \sum_a (j_{-1}^a j_0^a + j_{-1}^a j_0^a) |\phi_R^r\rangle \\ &= \frac{1}{k + C_{\mathfrak{g}}} \sum_a j_{-1}^a \sum_s (t_R^a)^r_s |\phi_R^s\rangle, \end{aligned}$$

where we employed Eq. (3.23). Writing this expressing using the correspondences (3.19) and (3.22) in terms of fields, we obtain

$$\left(\widehat{L}_{-1} - \frac{1}{k + C_{\mathfrak{g}}} \sum_a \widehat{j}_{-1}^a t_R^a \right) \phi_R(z) = 0.$$

Note that in order to make sense of this matrix equation, there is an identity matrix implied for \widehat{L}_{-1} . We can then insert this zero into a correlation function leading to the trivially satisfied equation

$$0 = \langle \phi_{R_1}(w_1) \dots \left(\widehat{L}_{-1} - \frac{1}{k + C_{\mathfrak{g}}} \sum_a \widehat{j}_{-1}^a t_{R_i}^a \right) \phi_{R_i}(w_i) \dots \phi_{R_N}(w_N) \rangle, \quad (3.24)$$

for each $i = 1, \dots, N$. From Eq. (3.19) we recall that \widehat{L}_{-1} acting on $\phi_{R_i}(w_i)$ gives $\widehat{L}_{-1} \phi_{R_i}(w_i) = \partial_{w_i} \phi_{R_i}(w_i)$, and for the second term in Eq. (3.24) we use Eq. (3.20) to calculate

$$\begin{aligned} & \langle \phi_{R_1}(w_1) \dots (\widehat{j}_{-1}^a \phi_{R_i})(w_i) \dots \phi_{R_N}(w_N) \rangle \\ &= \oint_{\mathcal{C}(w_i)} \frac{dz}{2\pi i} \frac{1}{z - w_i} \langle j^a(z) \phi_{R_1}(w_1) \dots \phi_{R_N}(w_N) \rangle \\ &= - \sum_{j \neq i} \oint_{\mathcal{C}(w_j)} \frac{dz}{2\pi i} \frac{1}{z - w_i} \frac{1}{z - w_j} t_{R_j}^a \langle \phi_{R_1}(w_1) \dots \phi_{R_N}(w_N) \rangle \\ &= - \sum_{j \neq i} \frac{1}{w_j - w_i} t_{R_j}^a \langle \phi_{R_1}(w_1) \dots \phi_{R_N}(w_N) \rangle. \end{aligned}$$

Note that here we employed the deformation of contour integrals shown in Fig. 2.7. Using these results in Eq. (3.24), we arrive at the celebrated Knizhnik–Zamolodchikov equation

$$\left(\partial_{w_i} - \frac{1}{k + C_{\mathfrak{g}}} \sum_{j \neq i} \frac{\sum_a t_{R_i}^a \otimes t_{R_j}^a}{w_i - w_j} \right) \langle \phi_{R_1}(w_1) \dots \phi_{R_N}(w_N) \rangle = 0,$$

for $i = 1, \dots, N$ where the tensor product again indicates that $t_{R_i}^a$ acts on ϕ_{R_i} and $t_{R_j}^a$ on ϕ_{R_j} .

The solutions to these equations are the correlation functions of Kač–Moody primary fields; however, they are difficult to solve in full generality. But for four-point correlators, solutions in a closed form in terms of hypergeometric functions are known.

3.6 Coset Construction

The conformal field theories based on Kač–Moody algebras contain currents, that is, fields of conformal dimension $h = 1$, which is in contrast to the minimal unitary models of $\text{Vir}_{(c,h)}$ with $0 < c < 1$ not containing any such fields. We will now present the so-called Coset construction, also known as the Goddard–Kent–Olive (GKO) construction, that provides many minimal model CFTs from Kač–Moody algebras. Again, we will discuss the $\mathfrak{su}(2)$ case as an illustrating example.

Quotient Theories

We start with the Kač–Moody algebra $\hat{\mathfrak{g}}_{k_{\mathfrak{g}}}$ originating from the Lie algebra \mathfrak{g} which contains a subalgebra $\mathfrak{h} \subset \mathfrak{g}$. As usual, we will denote the Kač–Moody algebra corresponding to \mathfrak{h} by $\hat{\mathfrak{h}}_{k_{\mathfrak{h}}}$. Referring to Eq. (3.6), the Sugawara energy–momentum tensors read

$$T_{\mathfrak{g}}(z) = \frac{1}{2(k_{\mathfrak{g}} + C_{\mathfrak{g}})} \sum_{a=1}^{\dim \mathfrak{g}} N(j_{\mathfrak{g}}^a j_{\mathfrak{g}}^a)(z),$$

$$T_{\mathfrak{h}}(z) = \frac{1}{2(k_{\mathfrak{h}} + C_{\mathfrak{h}})} \sum_{b=1}^{\dim \mathfrak{h}} N(j_{\mathfrak{h}}^b j_{\mathfrak{h}}^b)(z),$$

and since the current $j_{\mathfrak{h}}^b$ corresponding to $\hat{\mathfrak{h}}_{k_{\mathfrak{h}}}$ is a primary field of dimension $h = 1$ with respect to both $T_{\mathfrak{g}}$ and $T_{\mathfrak{h}}$, the OPEs with the energy–momentum tensors have the form

$$T_{\mathfrak{g}}(z) j_{\mathfrak{h}}^b(w) = \frac{j_{\mathfrak{h}}^b(w)}{(z-w)^2} + \frac{\partial_w j_{\mathfrak{h}}^b(w)}{z-w} + \dots,$$

$$T_{\mathfrak{h}}(z) j_{\mathfrak{h}}^b(w) = \frac{j_{\mathfrak{h}}^b(w)}{(z-w)^2} + \frac{\partial_w j_{\mathfrak{h}}^b(w)}{z-w} + \dots.$$

Taking the difference of these two equations and observing that $T_{\mathfrak{h}}$ is constructed only from $j_{\mathfrak{h}}^b$, we arrive at the OPEs

$$\begin{aligned} (T_{\mathfrak{g}} - T_{\mathfrak{h}})(z) j_{\mathfrak{h}}^b(w) &= \text{regular}, \\ (T_{\mathfrak{g}} - T_{\mathfrak{h}})(z) T_{\mathfrak{h}}(w) &= \text{regular}. \end{aligned} \quad (3.25)$$

Therefore, the splitting

$$T_{\mathfrak{g}} = (T_{\mathfrak{g}} - T_{\mathfrak{h}}) + T_{\mathfrak{h}} = T_{\mathfrak{g}/\mathfrak{h}} + T_{\mathfrak{h}} \quad \text{with} \quad T_{\mathfrak{g}/\mathfrak{h}} := T_{\mathfrak{g}} - T_{\mathfrak{h}}$$

gives a decomposition of the Virasoro algebra generated by $T_{\mathfrak{g}}$ into two mutually commuting Virasoro subalgebras since $(T_{\mathfrak{g}} - T_{\mathfrak{h}})(z)T_{\mathfrak{h}}(w)$ is regular. Employing then Eq. (3.25), we obtain the relations

$$T_{\mathfrak{g}/\mathfrak{h}} T_{\mathfrak{g}/\mathfrak{h}} = T_{\mathfrak{g}/\mathfrak{h}} T_{\mathfrak{g}} = T_{\mathfrak{g}} T_{\mathfrak{g}} - T_{\mathfrak{h}} T_{\mathfrak{g}} = T_{\mathfrak{g}} T_{\mathfrak{g}} - T_{\mathfrak{h}} T_{\mathfrak{h}}$$

up to regular terms. Therefore, the energy–momentum tensor $T_{\mathfrak{g}/\mathfrak{h}}$ satisfies the Virasoro algebra with central charge

$$c_{\mathfrak{g}/\mathfrak{h}} = c_{\mathfrak{g}} - c_{\mathfrak{h}} = \frac{k_{\mathfrak{g}} \dim \mathfrak{g}}{k_{\mathfrak{g}} + C_{\mathfrak{g}}} - \frac{k_{\mathfrak{h}} \dim \mathfrak{h}}{k_{\mathfrak{h}} + C_{\mathfrak{h}}}. \quad (3.26)$$

We finally state that the quotient (or coset) theory contains all operators of $\hat{\mathfrak{g}}_k$ which have a non-singular OPE with the operators of $\hat{\mathfrak{h}}_k$. In the present context, this property just means that the two algebras commute. Simple examples for such coset theories are the parafermions $\widehat{\mathfrak{su}}(2)_k/\widehat{\mathfrak{u}}(1)_1$. Since the central charge of any $\widehat{\mathfrak{u}}(1)_k$ theory is one, using the results from p. 91, the central charge for the parafermions is found as

$$c = \frac{3k}{k+2} - 1 = \frac{2(k-1)}{k+2}. \quad (3.27)$$

Special Coset Constructions

Another important class of coset construction is $(\hat{\mathfrak{g}}_{k_1} \times \hat{\mathfrak{g}}_{k_2})/\hat{\mathfrak{g}}_k$ where the algebras $\hat{\mathfrak{g}}_{k_i}$ are generated by $j_{(i)}^a$ and $\hat{\mathfrak{g}}_k$ is generated by $j^a = j_{(1)}^a + j_{(2)}^a$. Note that by definition, the Laurent modes of $j_{(1)}^a$ and $j_{(2)}^a$ commute, and so the commutation relations for the combined currents j^a are found as

$$[j_m^a, j_n^b] = i \sum_c f^{abc} j_{m+n}^c + (k_1 + k_2) m \delta^{ab} \delta_{m+n,0},$$

with $f^{abc} = f_{(1)}^{abc} + f_{(2)}^{abc}$ and so the level of the Kač–Moody algebra $\hat{\mathfrak{g}}_k$ is $k = k_1 + k_2$. Such cosets are also called diagonal cosets and their energy–momentum tensor has the form

$$T_{(\mathfrak{g}_{k_1} \times \mathfrak{g}_{k_2})/\mathfrak{g}_{k_1+k_2}} = T_{\mathfrak{g}_{k_1}} + T_{\mathfrak{g}_{k_2}} - T_{\mathfrak{g}_{k_1+k_2}}$$

analogously to the previous paragraph. One of the simplest example for a diagonal coset is

$$\frac{\widehat{\mathfrak{su}}(2)_k \times \widehat{\mathfrak{su}}(2)_1}{\widehat{\mathfrak{su}}(2)_{k+1}}, \quad (3.28)$$

with $k \geq 1$. Noting that by definition the OPE $T_{\mathfrak{g}_{k_1}} T_{\mathfrak{g}_{k_2}}$ is regular, the central charge is found using Eq. (3.26) as

$$c = \frac{3k}{k+2} + 1 - \frac{3(k+1)}{k+3} = 1 - \frac{6}{(k+2)(k+3)}. \quad (3.29)$$

Recalling our results from Sect. 2.10, we see that these are precisely the values $0 < c < 1$ from the unitary series of the Virasoro algebra. Since for unitary representations of just the Virasoro algebra there are no currents, we expect them to be absent also in the coset construction. And indeed, there is no subalgebra of currents $j_{(1)}^a + j_{(2)}^b$ commuting with all $j^c = j_{(1)}^c + j_{(2)}^c$ and so the coset theory does not contain any currents. In summary, although not proven rigorously here, the theories determined by the coset (3.28) are the unitary minimal models of the Virasoro algebra studied in Sect. 2.10.

Hilbert Space and Branching Rules

Let us now turn to the Hilbert space. Under the decomposition $T_{\mathfrak{g}} = T_{\mathfrak{h}} + T_{\mathfrak{g}/\mathfrak{h}}$, a highest weight representation $(\lambda_{\mathfrak{g}})$ of $\hat{\mathfrak{g}}$ must decompose into a direct sum of tensor products of highest weight representations of $\hat{\mathfrak{h}}$ and the coset theory $\hat{\mathfrak{g}}/\hat{\mathfrak{h}}$

$$(\lambda_{\mathfrak{g}}) = \bigoplus_{\lambda_{\mathfrak{h}}} (\lambda_{\mathfrak{h}}) \otimes (\lambda_{\mathfrak{g}/\mathfrak{h}}). \tag{3.30}$$

These relations are the so-called branching rules. In the case of the coset (3.28), one finds that a highest weight representation of $\hat{\mathfrak{g}} = \widehat{\mathfrak{su}}(2)_k \times \widehat{\mathfrak{su}}(2)_1$ decomposes into highest weights of $\hat{\mathfrak{h}} = \widehat{\mathfrak{su}}(2)_{k+1}$ and $\hat{\mathfrak{g}}/\hat{\mathfrak{h}} = (\widehat{\mathfrak{su}}(2)_k \times \widehat{\mathfrak{su}}(2)_1)/\widehat{\mathfrak{su}}(2)_{k+1}$ as

$$(p-1)_k \otimes (\epsilon)_1 = \bigoplus_{\substack{0 \leq (q-1) \leq k+1 \\ p-q+\epsilon \equiv 0 \pmod{2}}} (q-1)_{k+1} \otimes (h_{p,q}(m)), \tag{3.31}$$

with $\epsilon = 0, 1$, $m = k + 2$ and $0 \leq (p-1) \leq k$. Here, $(l)_k$ denotes a spin $\frac{l}{2}$ representation of $\widehat{\mathfrak{su}}(2)_k$ whose conformal dimension is determined using the relation below Eq. (3.10). Note furthermore that all highest weights $h_{p,q}(m)$ of the Virasoro unitary model appear and that $p - q$ is even for $\epsilon = 0$ and it is odd for $\epsilon = 1$.

Before we turn to more general examples, let us illustrate the decomposition (3.31) for the Ising model with $k = 1$ and thus $m = 3$. A highest weight representation of $\widehat{\mathfrak{su}}(2)_1 \times \widehat{\mathfrak{su}}(2)_1$ decomposes into HWRs of $\widehat{\mathfrak{su}}(2)_2$ and $\text{Vir}_{c=\frac{1}{2}}$ as

$$\begin{aligned} (0)_1 \otimes (0)_1 &= \left[(0)_2 \otimes (h_{1,1})^{(0)} \right] \oplus \left[(2)_2^{(\frac{1}{2})} \otimes (h_{(1,3)})^{(\frac{1}{2})} \right], \\ (0)_1 \otimes (1)_1^{(\frac{1}{4})} &= \left[(1)_2^{(\frac{3}{16})} \otimes (h_{1,2})^{(\frac{1}{16})} \right], \\ (1)_1^{(\frac{1}{4})} \otimes (0)_1 &= \left[(1)_2^{(\frac{3}{16})} \otimes (h_{2,2})^{(\frac{1}{16})} \right], \\ (1)_1^{(\frac{1}{4})} \otimes (1)_1^{(\frac{1}{4})} &= \left[(0)_2 \otimes (h_{2,1})^{(\frac{1}{2})} \right] \oplus \left[(2)_2^{(\frac{1}{2})} \oplus (h_{(2,3)})^{(0)} \right], \end{aligned}$$

where (0) , (1) and (2) , respectively, denote the singlet, spin 1/2 and spin 1 representation of $\widehat{\mathfrak{su}}(2)_1$ and $\widehat{\mathfrak{su}}(2)_2$. The superscript stands for the conformal weight of the particular highest weight representation.

Examples

The coset construction allows to define many rational CFTs. In closing this section, we will briefly consider two examples which will be important later.

- The first example is $(\widehat{\mathfrak{su}}(2)_k \times \widehat{\mathfrak{su}}(2)_2)/\widehat{\mathfrak{su}}(2)_{k+2}$ with central charge

$$c = \frac{3k}{k+2} + \frac{3}{2} - \frac{3(k+2)}{k+4} = \frac{3}{2} \left(1 - \frac{8}{(k+2)(k+4)} \right).$$

As we will see in Chap. 5, this is the unitary series of the $\mathcal{N} = 1$ supersymmetric extension of the Virasoro algebra.

- The second example is $(\widehat{\mathfrak{su}}(3)_k \times \widehat{\mathfrak{su}}(3)_1) / \widehat{\mathfrak{su}}(3)_{k+1}$ with central charge

$$c = \frac{8k}{k+3} + 2 - \frac{8(k+1)}{k+4} = 2 \left(1 - \frac{12}{(k+3)(k+4)} \right).$$

It is an interesting question whether these theories also arise as a unitary discrete series of rational CFTs for an extended symmetry algebra. In fact, it turns out that the vacuum representation in this case contains besides the energy–momentum tensor $T(z)$ another chiral primary field which has conformal dimension $h=3$. We will investigate such extensions of the Virasoro algebra in the following section.

3.7 \mathcal{W} Algebras

The symmetry algebras we have studied so far are the Virasoro algebra and Kač–Moody algebra generated by currents $j(z)$ of conformal dimension $h = 1$. However, in the last section we also considered coset constructions of CFTs where in particular the diagonal coset $(\widehat{\mathfrak{su}}(3)_k \times \widehat{\mathfrak{su}}(3)_1) / \widehat{\mathfrak{su}}(3)_{k+1}$ appeared. A detailed analysis shows that it does not contain any currents but of course the energy–momentum tensor $T(z)$. In addition, the coset contains a chiral primary with conformal dimension $h = 3$ which happens to be the order of the second Casimir operator of $\mathfrak{su}(3)$.

It is natural to ask the question if there exist extensions of the Virasoro algebra by chiral primary fields of conformal dimension $h > 2$, and if yes, what the structure of the algebra is. In Sect. 2.6, we have worked out in fair generality the structure of such operator algebras. In the present section, we will apply these techniques to the construction of extended chiral algebras \mathcal{A} .

The Minimal Extension

We start with extending the usual Virasoro algebra generated by $L(z)$ by including a chiral primary of conformal dimension $h = 3$ denoted as $W_3(z)$ ³. We then obtain the following commutation relations:

$$\begin{aligned} [L_m, L_n] &= (m-n) L_{m+n} + \frac{c}{12} (m^3 - m) \delta_{m+n,0}, \\ [L_m, W_n] &= (2m-n) W_{m+n}, \end{aligned} \tag{3.32}$$

³ In the present context, it is customary to write $L(z)$ instead of $T(z)$.

where the first line describes just the Virasoro algebra and W_m are the Laurent modes of $W_3(z)$. Recalling Eq. (2.45), the second line is the statement that W_3 is a primary field of conformal dimension $h = 3$. The commutator of the Laurent modes of $W_3(z)$ can be determined using the general expression (2.54)

$$\begin{aligned} [W_m, W_n] &= C_{WW}^L p_{332}(m, n) L_{m+n} + C_{WW}^W p_{333}(m, n) W_{m+n} \\ &\quad + C_{WW}^{\mathcal{N}(LL)} p_{334}(m, n) \mathcal{N}(LL)_{m+n} + d_{WW} \binom{m+2}{5} \delta_{m+n,0}. \end{aligned}$$

Let us have a closer look at the terms appearing on the right-hand side of this equation.

- Similar to the Virasoro algebra where we have chosen the normalisation of the two-point function to be $d_{LL} = \frac{c}{2}$, we will now choose the normalisation d_{WW} to be $d_{WW} = \frac{c}{3}$.
- From the explicit formulas (2.55), we find $p_{\Delta\Delta(2k+1)}(m, n) = p_{\Delta\Delta(2k+1)}(n, m)$, where Δ denotes some field of the theory. In order for the commutator to respect the (anti-)symmetry, it follows that $C_{\Delta\Delta}^{(2k+1)} = 0$ and thus only fields of even conformal dimension h can appear on the right-hand side of $[W_m, W_n]$. In particular, this means that $C_{WW}^W = 0$.
- From Eq. (2.55), we find that $p_{233}(m, n) = \frac{2m-n}{3}$ and by comparing with Eq. (3.32), we obtain $C_{LW}^W = 3$. We then recall from p. 34 that $C_{ijk} = C_{ij}^l d_{lk}$ which allows us to calculate

$$C_{WW}^L = C_{WWL} (d_{LL})^{-1} = C_{LW}^W d_{WW} (d_{LL})^{-1} = 3 \cdot \frac{c}{3} \cdot \frac{2}{c} = 2.$$

- Finally, above we have employed the quasi-primary projection of $\mathcal{N}(LL)$ defined in Eq. (2.72) which reads $\mathcal{N}(LL)(z) = N(LL)(z) - \frac{3}{10} \partial^2 L$.

Combining these results, we can become more concrete about the commutator of two $W_3(z)$ Laurent modes

$$\begin{aligned} [W_m, W_n] &= 2 p_{332}(m, n) L_{m+n} + C_{WW}^{\mathcal{N}(LL)} p_{334}(m, n) \mathcal{N}(LL)_{m+n} \\ &\quad + \frac{c}{3} \binom{m+2}{5} \delta_{m+n,0}. \end{aligned}$$

Determining the Constant $C_{WW}^{\mathcal{N}(LL)}$

We will now determine the constant $C_{WW}^{\mathcal{N}(LL)}$ via the relation $C_{ijk} = C_{ij}^l d_{lk}$. To do so, we have to compute $C_{WW\mathcal{N}(LL)}$ and $d_{\mathcal{N}(LL)\mathcal{N}(LL)}$ where the latter is essentially the two-point function of the field $\mathcal{N}(LL)$. From Sect. 2.8 we recall that

$$\mathcal{N}(LL)_{-4} |0\rangle = \left(L_{-2} L_{-2} - \frac{3}{10} \cdot 2 L_{-4} \right) |0\rangle,$$

and the norm of this state is evaluated by applying the commutation relations of the Virasoro algebra. Specifically, with the help of the usual techniques and Eq. (2.56) we find

$$\left. \begin{aligned} \langle 0 | L_2 L_2 L_{-2} L_{-2} | 0 \rangle &= \frac{c^2}{2} + 4c, \\ \langle 0 | L_4 L_{-4} | 0 \rangle &= 5c, \\ \langle 0 | L_4 L_{-2} L_{-2} | 0 \rangle &= 3c, \end{aligned} \right\} \Rightarrow d_{\mathcal{N}(LL)\mathcal{N}(LL)} = \frac{(5c + 22)c}{10}.$$

For the three-point function $\langle W W \mathcal{N}(LL) \rangle$, we note that the state corresponding to the field $W_3(z)$ is $W_{-3}|0\rangle$. Utilising Eqs. (2.56) and (2.57) and using the commutation relation (3.32), we calculate

$$\begin{aligned} C_{WW\mathcal{N}(LL)} &= \left\langle 0 \left| W_3 W_1 \left(L_{-2} L_{-2} - \frac{3}{5} L_{-4} \right) \right| 0 \right\rangle \\ &= \langle 0 | W_3 [W_1, L_{-2} L_{-2}] | 0 \rangle - \frac{3}{5} \langle 0 | W_3 [W_1, L_{-4}] | 0 \rangle \\ &= 5 \langle 0 | W_3 (L_{-2} W_{-1} + W_{-1} L_{-2}) | 0 \rangle - \frac{27}{5} \langle 0 | W_3 W_{-3} | 0 \rangle \\ &= 5 \langle 0 | W_3 [W_{-1}, L_{-2}] | 0 \rangle - \frac{27}{5} \langle 0 | W_3 W_{-3} | 0 \rangle \\ &= \frac{48}{5} \langle 0 | W_3 W_{-3} | 0 \rangle = \frac{48}{5} d_{WW} = \frac{16}{5} c. \end{aligned}$$

Employing the inverse of the relation $C_{ijk} = C_{ij}^l d_{lk}$ and our result for $d_{\mathcal{N}(LL)\mathcal{N}(LL)}$, we obtain

$$C_{WW}^{\mathcal{N}(LL)} = C_{WW\mathcal{N}(LL)} (d_{\mathcal{N}(LL)\mathcal{N}(LL)})^{-1} = \frac{32}{5c + 22}.$$

In passing we note that here we have computed nothing else than one of the coefficients $\beta_{WW}^{L,(k)}$ introduced in Sect. 2.12.

The Algebra $\mathcal{W}(2,3)$

We can now write down the full expression for the commutator of two $W_3(z)$ Laurent modes as

$$\begin{aligned} [W_m, W_n] &= 2 p_{332}(m, n) L_{m+n} + \frac{32}{5c + 22} p_{334}(m, n) \mathcal{N}(LL)_{m+n} \\ &\quad + \frac{c}{3} \binom{m+2}{5} \delta_{m+n,0}. \end{aligned}$$

However, one still needs to check whether the algebra defined by these relations satisfies the Jacobi identities, which at the level of OPEs are equivalent to the crossing symmetry. In particular, one has to check that

$$0 = [[W_m, W_n], W_q] + [[W_q, W_m], W_n] + [[W_n, W_q], W_m],$$

which in our present case is automatically satisfied for all values of the central charge. Thus, there are no further constraints and the so-called $\mathcal{W}(2, 3)$ algebra closes for all values of c .

The generators $L(z)$ and $W_3(z)$ form an algebra which is not linear in L and W_3 but involves normal ordered products in the commutation relation of the Laurent modes. This implies that in general the algebra closes only in the so-called enveloping algebra of L_m and W_m . Such algebras are called \mathcal{W} algebras and they naturally appear as extended chiral algebras of CFTs. The extension of the Virasoro algebra by chiral primaries of conformal dimensions $\{\Delta_1, \dots, \Delta_N\}$ is denoted as $\mathcal{W}(2, \Delta_1, \dots, \Delta_N)$.

In this section, we have constructed the $\mathcal{W}(2, 3)$ algebra. Computing the Kač-determinant for this theory, one finds a discrete series of unitary rational models with central charges

$$c = 2 \left(1 - \frac{12}{(k+3)(k+4)} \right) \quad (3.33)$$

for $k \geq 1$. However, it can be shown that the chiral algebra of the GKO coset

$$\frac{\widehat{\mathfrak{su}}(3)_k \times \widehat{\mathfrak{su}}(3)_1}{\widehat{\mathfrak{su}}(3)_{k+1}} \quad (3.34)$$

precisely is the $\mathcal{W}(2, 3)$ algebra. We will not prove this statement but only point out that the central charges for the $\mathfrak{su}(3)$ diagonal coset (3.34) agree with the central charges (3.33) of $\mathcal{W}(2, 3)$.

An example for theories with $\mathcal{W}(2, 3)$ symmetry is the three-state Potts model with $k = 1$ and $c = \frac{4}{5}$ also appearing in the unitary series of just the Virasoro algebra. We will see later how the relation between the $\mathcal{W}(2, 3)$ algebra and the Virasoro algebra can be made more precise.

Generalisations

Let us ask the question how to generalise these ideas. We note that $\mathfrak{su}(N)$ has independent Casimir operators of degree $\{2, 3, \dots, N\}$, which is in relation to the fact that the diagonal coset $(\widehat{\mathfrak{su}}(N)_k \times \widehat{\mathfrak{su}}(N)_1) / \widehat{\mathfrak{su}}(N)_{k+1}$ has an extended $\mathcal{W}(2, 3, \dots, N)$ symmetry. Up to $N = 5$, the corresponding algebras have been constructed explicitly using the methods above and the central charges for these models are given by the unitary minimal series

$$c = (N - 1) \left(1 - \frac{N(N + 1)}{(m + N)(m + N + 1)} \right) \quad \text{with } m \geq 1 .$$

Therefore, one might envision that the classification of \mathcal{W} algebras leads to a classification of rational models; however, such a programme has not been completed up to now. Here, let us give just one more example of which is the next natural candidate for an extended symmetry algebra, namely $\mathcal{W}(2, 4)$.

The Algebra $\mathcal{W}(2, 4)$

We note that the higher the degree Δ of $W_\Delta(z)$ is, the more the normal ordered products appear in the commutator $[W_m, W_n]$. If $W_4(z)$ is a chiral primary of conformal dimension $h = 4$, then the commutator of the Laurent modes with the energy-momentum modes reads

$$[L_m, W_n] = (3m - n) W_{m+n} .$$

For the commutator of the W_m modes, we use the general formula (2.54) from Sect. 2.6 to obtain

$$\begin{aligned} [W_m, W_n] &= C_{WW}^L p_{442}(m, n) L_{m+n} + C_{WW}^W p_{444}(m, n) W_{m+n} \\ &+ C_{WW}^{\mathcal{N}(LL)} p_{444}(m, n) \mathcal{N}(LL)_{m+n} \\ &+ C_{WW}^{\mathcal{N}(L\partial^2 L)} p_{446}(m, n) \mathcal{N}(L\partial^2 L)_{m+n} \\ &+ C_{WW}^{\mathcal{N}(\mathcal{N}(LL)L)} p_{446}(m, n) \mathcal{N}(\mathcal{N}(LL)L)_{m+n} \\ &+ C_{WW}^{\mathcal{N}(WL)} p_{446}(m, n) \mathcal{N}(WL)_{m+n} + \frac{c}{4} \binom{m+3}{7} \delta_{m+n,0} , \end{aligned}$$

where we normalised the two-point function in analogy to our previous cases as $d_{WW} = \frac{c}{4}$. The fields appearing on the right-hand side are restricted by the requirement from p. 35 that $h < 2 \cdot 4$ and by our previous observation that all fields on the right-hand side need to have even conformal dimensions.

The constants $p_{ijk}(m, n)$ can be calculated using Eq. (2.55) and the structure constants of the descendants are determined as

$$\begin{aligned} C_{WW}^L &= 2 , \\ C_{WW}^{\mathcal{N}(LL)} &= \frac{42}{5c + 22} , \\ C_{WW}^{\mathcal{N}(L\partial^2 L)} &= \frac{3(19c - 524)}{10(7c + 68)(2c - 1)} , \end{aligned}$$

$$C_{WW}^{\mathcal{N}(\mathcal{N}(LL)L)} = \frac{24(72c + 13)}{(5c + 22)(7c + 68)(2c - 1)},$$

$$C_{WW}^{\mathcal{N}(WL)} = \frac{28}{3(c + 24)} C_{WW}^W.$$

Here, the central charge c and the self-coupling of the primary field C_{WW}^W are still free parameters. However, they can be fixed by the Jacobi identity of three W_m modes giving one constraint

$$(C_{WW}^W)^2 = \frac{54(c + 24)(c^2 - 172c + 196)}{(5c + 22)(7c + 68)(2c - 1)}.$$

Remarks

- For higher \mathcal{W} algebras $\mathcal{W}(2, \Delta)$, the structure becomes more and more involved. For instance, $\mathcal{W}(2, 5)$ closes only for a finite number of values $c = \frac{6}{7}, -7, -\frac{350}{11}, 134 \pm 60\sqrt{5}$.
- The algebra $\mathcal{W}(2, 6)$ closes for all values of c .
- The Casimir operators of a Lie algebra form itself a closed algebra called the *Casimir algebra*. For instance, as we have seen in Sect. 3.3, the Casimir operators of $\mathfrak{su}(2)$ are the identity and the zero modes of the Sugawara energy–momentum tensor (3.6). We then note that the algebra $\mathcal{W}(2, 4)$ studied in the last paragraph is the Casimir algebra of $\mathfrak{so}(5)$, and $\mathcal{W}(2, 6)$ is the Casimir algebra of \mathfrak{g}_2 .

Further Reading

1. V. G. Kac, “Infinite dimensional Lie algebras,” Cambridge, UK: University Press (1990) 400p.
2. V. G. Kac and D. H. Peterson, “Infinite dimensional Lie algebras, theta functions and modular forms,” *Adv. Math.* **53** (1984) 125–264.
3. V. G. Knizhnik and A. B. Zamolodchikov, “Current algebra and Wess-Zumino model in two dimensions,” *Nucl. Phys.* **B247** (1984) 83–103.
4. P. Goddard, A. Kent, and D. I. Olive, “Virasoro algebras and coset space models,” *Phys. Lett.* **B152** (1985) 88.
5. P. Goddard, A. Kent, and D. I. Olive, “Unitary representations of the Virasoro and Supervirasoro algebras,” *Commun. Math. Phys.* **103** (1986) 105–119.
6. A. B. Zamolodchikov, “Infinite additional symmetries in two-dimensional conformal quantum field theory,” *Theor. Math. Phys.* **65** (1985) 1205–1213.
7. P. Bouwknegt and K. Schoutens, “W symmetry,” *Adv. Ser. Math. Phys.* **22** (1995) 1–875.
8. R. Blumenhagen, A. Flohr, M. Kliem, W. Nahm, A. Recknagel, and R. Varnhagen, “W algebras with two and three generators,” *Nucl. Phys.* **B361** (1991) 255–289.

Chapter 4

Conformal Field Theory on the Torus

So far, we have been discussing conformal field theories defined on the complex plane respectively the Riemann sphere. In string theory, such theories correspond to the tree-level in perturbation theory which is illustrated in Fig. 4.1(a). As a characteristic feature of CFTs on the complex plane, we observed that the chiral and anti-chiral sectors decouple; in particular, in many cases we were able to treat both sectors independent of each other. We also saw that the chiral and anti-chiral CFTs can have extended symmetry algebras \mathcal{A} and $\overline{\mathcal{A}}$, and we studied the allowed highest weight representations $[\phi_{h_i}]$ respectively $[\overline{\phi}_{\overline{h}_i}]$ as well as their fusion rules.

Except the computationally quite involved boot-strap method, we did not encounter any consistency condition restricting how the chiral and anti-chiral fields are combined into fields $\phi_{h_i, \overline{h}_j}(z, \overline{z})$. However, as is known for quantum field theories, a natural way to see which fields are actually present in a theory is to consider loop diagrams where all possible states can propagate in the loops. For conformal field theories, the equivalent is to study CFTs on higher genus Riemannian surfaces. The one-loop diagram corresponds to a torus, and we will see that indeed a new consistency condition, namely the so-called modular invariance, arises already for the vacuum diagram severely constraining the appearing non-chiral fields $\phi_{h_i, \overline{h}_j}(z, \overline{z})$. Note that here and in the following, we employ the jargon customary in string theory where the higher genus Riemannian surfaces correspond to string-loop diagrams as is illustrated in Fig. 4.1(b). In the present chapter, we will not consider arbitrary surfaces but focus on conformal field theories defined on the torus which is a Riemann surface of genus $g = 1$.

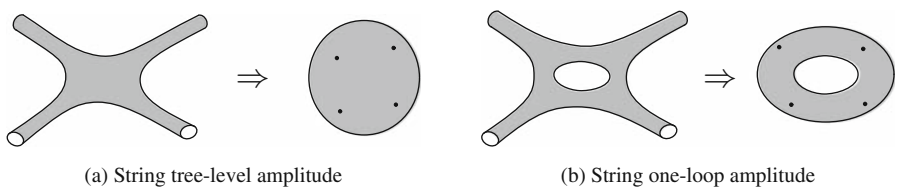

Fig. 4.1 A tree-level and a one-loop amplitude in string theory. The string diagrams with four closed strings stretching to infinity correspond, respectively, to a sphere and a torus with four vertex operators inserted

4.1 The Modular Group of the Torus and the Partition Function

To start with, let us recall that in Chap. 2 we considered conformal field theories defined on the complex plane \mathbb{C} respectively the Riemann sphere $S^2 = \mathbb{C} \cup \infty$. As we explained in Sect. 2.4, the theory on \mathbb{C} can be obtained from the theory defined on a cylinder via the mapping (2.23)

$$z = e^w = e^{x^0} \cdot e^{ix^1},$$

where z is the coordinate on \mathbb{C} and $w = x^0 + ix^1$ is the coordinate on the cylinder. In this way, we motivated the concept of radial quantisation and we introduced radial ordering for the evaluation of correlation functions as well as for operator product expansions. Let us emphasise that by studying the CFT on the complex plane, we were able to employ the power of complex analysis allowing us to deduce many features of two-dimensional CFTs.

In this chapter, we are going to study CFTs defined on a torus. The easiest way to obtain such a theory while using our previous results is to cut out a finite piece of the infinite cylinder described by $w = x^0 + ix^1$ and to identify the boundaries.

From the Complex Plane to the Cylinder

More precisely, the transition from the complex plane with coordinate z to the cylinder with coordinate w is achieved as follows. Recalling the definition (2.17), a primary field $\phi(z, \bar{z})$ defined on \mathbb{C} transforms under the conformal mapping $z = e^w$ as

$$\phi_{\text{cyl.}}(w, \bar{w}) = \left(\frac{\partial z}{\partial w} \right)^h \left(\frac{\partial \bar{z}}{\partial \bar{w}} \right)^{\bar{h}} \phi(z, \bar{z}) = z^h \bar{z}^{\bar{h}} \phi(z, \bar{z}). \quad (4.1)$$

Concentrating on the chiral sector, the mode expansion of a chiral field on the cylinder can then be inferred from the result on the complex plane using $z = e^w$. Concretely, we find

$$\phi_{\text{cyl.}}(w) = \left(\frac{\partial z}{\partial w} \right)^h \phi(z) = z^h \sum_n \phi_n z^{-n-h} = \sum_n \phi_n e^{-n w}. \quad (4.2)$$

Furthermore, from Eq. (4.1) we see that fields invariant under $z \mapsto e^{2\pi i} z$ on the complex plane pick up a phase $e^{2\pi i(h-\bar{h})}$ on the cylinder. If $(h - \bar{h})$ is not an integer, the type of boundary condition of a field is changed. Indeed, using Eq. (4.1), the Laurent expansion of a chiral fermion with $(h, \bar{h}) = (\frac{1}{2}, 0)$ on the cylinder reads

$$\psi_{\text{cyl.}}(w) = \sum_r \psi_r e^{-r w},$$

so that the Neveu–Schwarz sector with $r \in \mathbb{Z} + \frac{1}{2}$ is anti-invariant under $w \mapsto w + 2\pi i$ while the Ramond sector with $r \in \mathbb{Z}$ is invariant. This is just opposite to the boundary conditions on the complex plane given in Eq. (2.104).

Focus on the Energy–Momentum Tensor

Let us next consider the chiral part of the energy–momentum tensor. Since $T(z)$ is not a primary field, we cannot employ Eq. (4.1) to map it from the sphere to the cylinder. However, we have seen in Sect. 2.5 that under transformations $z \mapsto f(z)$ the energy–momentum tensor behaves as

$$T'(z) = \left(\frac{\partial f}{\partial z} \right)^2 T(f(z)) + \frac{c}{12} S(f(z), z), \quad (4.3)$$

with the Schwarzian derivative defined as

$$S(w, z) = \frac{1}{(\partial_z w)^2} \left((\partial_z w)(\partial_z^3 w) - \frac{3}{2} (\partial_z^2 w)^2 \right).$$

Using Eq. (4.3) with $z = f(w) = e^w$, we obtain

$$T_{\text{cyl.}}(w) = \left(\frac{\partial f(w)}{\partial w} \right)^2 T(f(w)) + \frac{c}{12} S(f(w), w) = z^2 T(z) - \frac{c}{24}, \quad (4.4)$$

where we employed that $S(z, w) = -\frac{1}{2}$. The Laurent mode expansion of the energy–momentum tensor on the cylinder therefore reads

$$T_{\text{cyl.}}(w) = \sum_{n \in \mathbb{Z}} L_n z^{-n} - \frac{c}{24} = \sum_{n \in \mathbb{Z}} \left(L_n - \frac{c}{24} \delta_{n,0} \right) e^{-n w},$$

so that in particular the zero mode gets shifted as

$$(L_{\text{cyl.}})_0 = L_0 - \frac{c}{24}. \quad (4.5)$$

Modular Group of the Torus

After having arrived on the cylinder, we will now perform the compactification to the torus. The torus \mathbb{T}^2 is obtained by cutting out a finite piece from the infinite cylinder and identifying the ends so that not only the space coordinate but also the time coordinate becomes periodic. However, before gluing together, there is the possibility to twist the ends of the cylinder.

As it turns out, it is useful to formalise this compactification from the plane to the torus in the following way. We note that a torus can be defined by identifying points w in the complex plane \mathbb{C} as

Fig. 4.2 Lattice of a torus generated by (α_1, α_2) conveniently chosen as $(1, \tau)$. The shaded region indicates the fundamental domain of the torus, and the torus itself is obtained by identifying opposite edges thereof

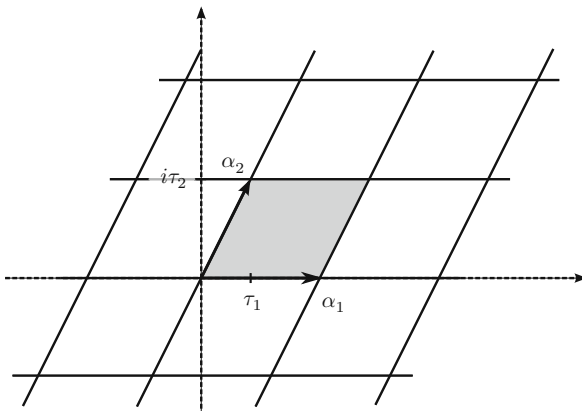

$$w \sim w + m \alpha_1 + n \alpha_2, \quad m, n \in \mathbb{Z},$$

where (α_1, α_2) is a pair of complex numbers. As illustrated in Fig. 4.2, this pair spans a lattice whose smallest cell is called the fundamental domain of the torus. From a geometrical point of view, the torus is then obtained by identifying opposite edges of the fundamental domain. The quantity describing the shape of the torus is called the complex structure or the modular parameter which is defined as

$$\tau = \frac{\alpha_2}{\alpha_1} = \tau_1 + i \tau_2. \tag{4.6}$$

However, there are different choices of (α_1, α_2) giving the same lattice and thus the same torus. To investigate this point further, let us assume that (α_1, α_2) and (β_1, β_2) both describe the same lattice. This means we can write the pair (β_1, β_2) in the following way:

$$\begin{pmatrix} \beta_1 \\ \beta_2 \end{pmatrix} = \begin{pmatrix} a & b \\ c & d \end{pmatrix} \begin{pmatrix} \alpha_1 \\ \alpha_2 \end{pmatrix}, \quad a, b, c, d \in \mathbb{Z}. \tag{4.7}$$

Clearly, in a similar fashion (α_1, α_2) should also be expressible in terms of (β_1, β_2) which amounts to the computation of the inverse relation

$$\begin{pmatrix} \alpha_1 \\ \alpha_2 \end{pmatrix} = \frac{1}{ad - bc} \begin{pmatrix} d & -b \\ -c & a \end{pmatrix} \begin{pmatrix} \beta_1 \\ \beta_2 \end{pmatrix}.$$

In general, for the inverse matrix to also have integer entries, we have to require that $ad - bc = \pm 1$ which just means that the unit cells in each basis should have the same volume (up to a sign). Furthermore, the lattice spanned by (α_1, α_2) is equal to the one spanned by $(-\alpha_1, -\alpha_2)$ and so we can divide out a \mathbb{Z}_2 action. Matrices with these properties are elements of $SL(2, \mathbb{Z})/\mathbb{Z}_2$ which implies that two pairs (α_1, α_2) and

(β_1, β_2) are related by $SL(2, \mathbb{Z})/\mathbb{Z}_2$ transformations. Finally, by choosing $(\alpha_1, \alpha_2) = (1, \tau)$ we can simplify Eq. (4.7) and summarise:

The modular group of the torus is an isometry group acting on the modular parameter τ as

$$\tau \mapsto \frac{a\tau + b}{c\tau + d} \quad \text{with} \quad \begin{pmatrix} a & b \\ c & d \end{pmatrix} \in SL(2, \mathbb{Z})/\mathbb{Z}_2 .$$

Let us now take a closer look at some particular modular transformations which will be important in the following.

- First, we consider a transformation from the torus lattice $(\alpha_1, \alpha_2) = (1, \tau)$ to $(1, \tau + 1)$ as illustrated in Fig. 4.3(a). Under this change the lattice is invariant, but the modular parameters are related by a so-called modular T -transformation

$$T : \tau \mapsto \tau + 1 .$$

- Second, as illustrated in Fig. 4.3(b), two lattices given by $(\alpha_1, \alpha_2) = (1, \tau)$ and $(\alpha_1, \alpha_2) = (1 + \tau, \tau)$ also define the same torus. They are related by a so-called U -transformation acting on the modular parameter τ as

$$U : \tau \mapsto \frac{\tau}{\tau + 1} .$$

- However, it turns out to be more convenient not to work with U but with S defined in the following way:

$$S : \tau \mapsto -\frac{1}{\tau} .$$

Note that this operation interchanges $(\alpha_1, \alpha_2) \leftrightarrow (-\alpha_2, \alpha_1)$.

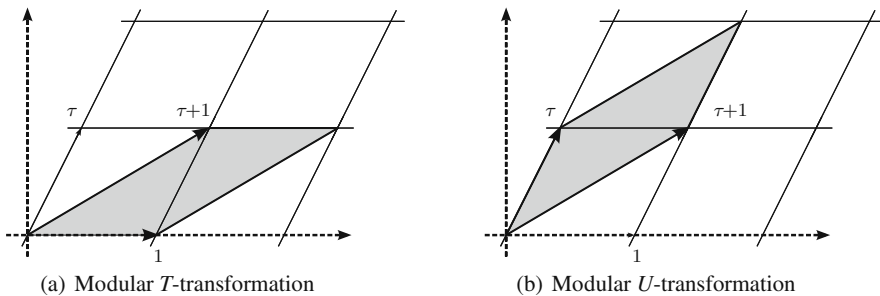

Fig. 4.3 Modular transformations of the torus generating the modular group $SL(2, \mathbb{Z})/\mathbb{Z}_2$

Next, writing the modular transformations in terms of $SL(2, \mathbb{Z})/\mathbb{Z}_2$ matrices acting on two vectors similarly as in Eq. (4.7), one can easily show that

$$S = U T^{-1} U, \quad S^2 = \mathbb{1}, \quad (ST)^3 = \mathbb{1}. \quad (4.8)$$

In the following, we will mainly consider T - and S -transformations which is sufficient for studying the behaviour under modular transformations since T and S are the generators of the modular group $SL(2, \mathbb{Z})/\mathbb{Z}_2$. However, this statement is non-trivial to prove.

Partition Function

Let us now define the partition function. For conformal field theories this is essentially the same object as in statistical mechanics where it is defined as a sum over all possible configurations weighted with the Boltzmann factor $\exp(-\beta H)$. Similarly, it corresponds to the generating functional in quantum field theory which is expected since the thermodynamic expression can be deduced from an Euclidean quantum field theory with time compactified on a circle of radius $R = \beta = 1/T$.

For the present situation on the torus, we slightly change our convention and choose $\text{Re } w$ to be the space direction and $\text{Im } w$ to be the time direction. This is no severe modification since an S -transformation exchanges both directions. Referring to Fig. 4.2, on a torus with non-trivial modular parameter $\tau = \tau_1 + i\tau_2$, we see that a time translation of length τ_2 does not end up at the starting point but is displaced in space by a τ_1 . Therefore, a ‘‘closed loop in time’’ on the torus involves also a space translation. This observation motivates the following definition of the CFT partition function¹:

$$\mathcal{Z}(\tau_1, \tau_2) = \text{Tr}_{\mathcal{H}} \left(e^{-2\pi\tau_2 H} e^{+2\pi\tau_1 P} \right), \quad (4.9)$$

where H is the Hamiltonian generating time translations and P denotes the momentum operator generating translations in space. The trace is taken over all states in the Hilbert space \mathcal{H} of the theory.

Next, let us determine the Hamiltonian for the CFT on the torus from the theory on the cylinder. The ground state energy is calculated from the zero–zero component of the energy–momentum tensor in the following way:

$$E_0 = \langle (T_{\text{cyl.}})_{00} \rangle \stackrel{(2.21)}{=} \langle T_{\text{cyl.}} \rangle + \langle \bar{T}_{\text{cyl.}} \rangle \stackrel{(4.4)}{=} -\frac{c + \bar{c}}{24},$$

where c and \bar{c} denote the central charges. Since H is the generator for time translations, it is plausible to write

¹ Note that we are working in Euclidian space–time which results in an unusual form of the time and space translation operators.

$$H_{\text{cyl.}} \simeq -\frac{\partial}{\partial t} + E_0 = -(\partial_w + \partial_{\bar{w}}) - \frac{c + \bar{c}}{24} = (L_{\text{cyl.}})_0 + (\bar{L}_{\text{cyl.}})_0 ,$$

where we used that $L_0 = -z\partial_z = -\partial_w$ together with Eq. (4.5). Performing the same steps for the momentum operator, we arrive at

$$P_{\text{cyl.}} = i \left((L_{\text{cyl.}})_0 - (\bar{L}_{\text{cyl.}})_0 \right) .$$

Employing these observations, we can express the partition function (4.9) in the following way:

$$\begin{aligned} \mathcal{Z}(\tau_1, \tau_2) &= \text{Tr}_{\mathcal{H}} \left(e^{-2\pi\tau_2((L_{\text{cyl.}})_0 + (\bar{L}_{\text{cyl.}})_0)} e^{+2\pi\tau_1 i((L_{\text{cyl.}})_0 - (\bar{L}_{\text{cyl.}})_0)} \right) \\ &= \text{Tr}_{\mathcal{H}} \left(e^{2\pi i\tau(L_{\text{cyl.}})_0} e^{-2\pi i\bar{\tau}(\bar{L}_{\text{cyl.}})_0} \right) . \end{aligned}$$

Utilising finally the relation between $(L_{\text{cyl.}})_0$ and L_0 given in Eq. (4.5), we can conclude the following:

The partition function for a conformal field theory defined on a torus with modular parameter τ is given by

$$\mathcal{Z}(\tau, \bar{\tau}) = \text{Tr}_{\mathcal{H}} \left(q^{L_0 - \frac{c}{24}} \bar{q}^{\bar{L}_0 - \frac{\bar{c}}{24}} \right) \quad \text{where } q = e^{2\pi i\tau} . \quad (4.10)$$

Note that since $SL(2, \mathbb{Z})/\mathbb{Z}_2$ transformations of the modular parameter τ do not change the torus, the CFT and in particular the partition function $\mathcal{Z}(\tau, \bar{\tau})$ have to be invariant under the action of the modular group. It is the main goal of this chapter to study this question which imposes strong constraints on the combination of chiral and anti-chiral fields. In order to get accustomed to this concept, in the following we will discuss some important examples in detail.

Remark

Let us finish this section with one remark. By using the Coleman–Weinberg formula for an effective action, it can be shown that the one-loop cosmological constant in string theory is given by

$$\Lambda \sim \int \frac{d^2\tau}{\text{Im}(\tau)} \mathcal{Z}(\tau, \bar{\tau}) . \quad (4.11)$$

This indicates that in string theory, the product of the partition function and the measure factor has to be modular invariant. Furthermore, in string theory physical states $|\phi_{\text{phys.}}\rangle$ have to satisfy

$$L_0 |\phi_{\text{phys.}}\rangle = \bar{L}_0 |\phi_{\text{phys.}}\rangle ,$$

which is ensured by the integration measure in Eq. (4.11) since $\int d\tau_1 \exp(2\pi \tau_1 P)$ leads to a δ -function for $L_0 - \bar{L}_0$.

4.2 Examples for Partition Functions

In the following subsections, we are going to discuss and construct modular invariant partition functions for some important examples. By doing so, we will illustrate the main concepts and techniques necessary to understand also more involved conformal field theories. A summary of all partition functions considered in this chapter can be found in Table 4.2 on p. 155.

4.2.1 The Free Boson

Partition Function

We start with the partition function of a single free boson. Since Eq. (4.10) is formulated in terms of L_0 and \bar{L}_0 defined on the complex plane, we can employ our results from Sect. 2.9.1. We thus recall some expressions needed in the following.

For the free boson, the Laurent modes of the energy–momentum tensor are written using the modes of the current $j(z) = i \partial X(z)$. In particular, we have

$$L_0 = \frac{1}{2} j_0 j_0 + \sum_{k \geq 1} j_{-k} j_k .$$

Since the current $j(z)$ is a field of conformal dimension one, we find that $j_n |0\rangle = 0$ for $n > -1$ and that states in the Hilbert space have the following form:

$$|n_1, n_2, n_3, \dots\rangle = j_{-1}^{n_1} j_{-2}^{n_2} j_{-3}^{n_3} \dots |0\rangle \quad \text{with } n_i \geq 0 \quad (4.12)$$

and $n_i \in \mathbb{Z}$. The current algebra for the Laurent modes reads

$$[j_m, j_n] = m \delta_{m, -n} .$$

Next, let us compute the action of L_0 on a state (4.12). Clearly, j_0 commutes with all j_{-k} and annihilates the vacuum. For the other terms we calculate

$$[j_{-k} j_k, j_{-k}^{n_k}] = n_k k j_{-k}^{n_k} , \quad (4.13)$$

and so we find for the zero Laurent mode of the energy–momentum tensor that

$$L_0 |n_1, n_2, n_3, \dots\rangle = \sum_{k \geq 1} j_{-1}^{n_1} j_{-2}^{n_2} \dots (j_{-k} j_k) j_{-k}^{n_k} \dots |0\rangle = \sum_{k \geq 1} k n_k |n_1, n_2, n_3, \dots\rangle .$$

We will utilise this last result in the calculation of the partition function where for simplicity we only focus on the holomorphic part. We compute

$$\begin{aligned}
 & \text{Tr} \left(q^{L_0 - \frac{c}{24}} \right) \\
 &= q^{-\frac{1}{24}} \sum_{n_1=0}^{\infty} \sum_{n_2=0}^{\infty} \sum_{n_3=0}^{\infty} \dots \left\langle n_1, n_2, n_3, \dots \left| \sum_{p=0}^{\infty} \frac{1}{p!} (2\pi\tau)^p (L_0)^p \right| n_1, n_2, n_3, \dots \right\rangle \\
 &= q^{-\frac{1}{24}} \sum_{n_1=0}^{\infty} \sum_{n_2=0}^{\infty} \sum_{n_3=0}^{\infty} \dots \left\langle n_1, n_2, n_3, \dots \left| \sum_{p=0}^{\infty} \frac{1}{p!} (2\pi\tau)^p \left(\sum_{k=1}^{\infty} k n_k \right)^p \right| n_1, n_2, n_3, \dots \right\rangle \\
 &= q^{-\frac{1}{24}} \sum_{n_1=0}^{\infty} \sum_{n_2=0}^{\infty} \sum_{n_3=0}^{\infty} \dots \left(q^{1 \cdot n_1} \cdot q^{2 \cdot n_2} \cdot q^{3 \cdot n_3} \cdot \dots \right) \\
 &= q^{-\frac{1}{24}} \left(\sum_{n_1=0}^{\infty} q^{1 n_1} \right) \cdot \left(\sum_{n_2=0}^{\infty} q^{2 n_2} \right) \cdot \left(\sum_{n_3=0}^{\infty} q^{3 n_3} \right) \cdot \dots \\
 &= q^{-\frac{1}{24}} \prod_{k=1}^{\infty} \sum_{n_k=0}^{\infty} q^{k n_k} = q^{-\frac{1}{24}} \prod_{k=1}^{\infty} \frac{1}{1 - q^k},
 \end{aligned}$$

where in the last step we employed the result for the infinite geometric series and the ellipses indicate that the structure extends to infinity. We then define the Dedekind η -function as

$$\boxed{\eta(\tau) = q^{\frac{1}{24}} \prod_{n=1}^{\infty} (1 - q^n)},$$

so that, including also the anti-holomorphic part, the partition function of a single free boson reads

$$\mathcal{Z}'_{\text{bos.}}(\tau, \bar{\tau}) = \frac{1}{|\eta(\tau)|^2}. \tag{4.14}$$

Modular Forms I: Modular Transformations of the η -Function

As we have mentioned above, the partition function has to be invariant under modular transformations. Since T and S generate the modular group, it is sufficient to require that $\mathcal{Z}(\tau, \bar{\tau})$ is invariant under T - and S -transformations. Let us therefore first check the invariance of Eq. (4.14) under modular T -transformations for which we find $T : q \mapsto e^{2\pi i} q$ leading to

$$\eta(\tau + 1) = e^{\frac{2\pi i}{24}} q^{\frac{1}{24}} \prod_{n=1}^{\infty} (1 - e^{2\pi i n} q^n) = e^{\frac{2\pi i}{24}} \eta(\tau).$$

Since the partition function (4.14) involves the absolute value squared of $\eta(\tau)$, we see that it is invariant under T -transformations. The modular S -transformation of the Dedekind η -function is more difficult to derive and we postpone the calculation until the end of Sect. 4.2.4. Let us, however, state that

The Dedekind η -function behaves under modular T - and S -transformations as

$$\eta(\tau + 1) = e^{\frac{\pi}{12}i} \eta(\tau), \quad \eta\left(-\frac{1}{\tau}\right) = \sqrt{-i\tau} \eta(\tau). \quad (4.15)$$

Modular Invariance of the Partition Function

Using Eq. (4.15), we observe that the partition function (4.14) is invariant under T -transformations but not under S -transformations, in particular, we find that $S : \mathcal{Z}'_{\text{bos.}}(\tau, \bar{\tau}) \mapsto |\tau|^{-1} \mathcal{Z}'_{\text{bos.}}(\tau, \bar{\tau})$. However, one can easily check that

$$\mathcal{Z}_{\text{bos.}}(\tau, \bar{\tau}) = \frac{1}{\sqrt{\tau_2}} \frac{1}{|\eta(\tau)|^2},$$

with τ_2 defined in Eq. (4.6) is indeed modular invariant. In string theory, the additional factor of $\tau_2^{-1/2}$ has a natural origin, as it stems from the integral over the unbounded centre of mass momentum of the string. We will become more concrete about this point in Sect. 6.7.

4.2.2 The Free Boson on a Circle

As a second example, let us now consider a free boson $X(z, \bar{z})$ compactified on a circle of radius R . This means, we identify the field $X(z, \bar{z})$ in the following way:

$$X(z, \bar{z}) \sim X(z, \bar{z}) + 2\pi Rn, \quad n \in \mathbb{Z}, \quad (4.16)$$

and so we can interpret $X(z, \bar{z})$ as an angular variable. However, let us emphasise that the field $X(z, \bar{z})$ in Eq. (4.16) characterising a circle has no direct relation with the manifold described by the variables z, \bar{z} . The latter is the space the theory is defined on, which in our case is the Riemann sphere respectively a torus. The calculation of the partition function in the present case is similar to the previous section. But, as we will see in a moment, the Hilbert space has changed slightly compared to the original theory due to new properties for the modes j_0 and \bar{j}_0 .

Partition Function

Our starting point is again the theory in the complex plane where also for the case that $X(z, \bar{z})$ is defined on a circle, the currents $j(z)$ and $\bar{j}(\bar{z})$ have the mode expansion

$$j(z) = i \partial X(z, \bar{z}) = \sum_{n \in \mathbb{Z}} j_n z^{-n-1}, \quad \bar{j}(\bar{z}) = i \bar{\partial} X(z, \bar{z}) = \sum_{n \in \mathbb{Z}} \bar{j}_n \bar{z}^{-n-1}.$$

As we have already done in Eq. (2.89), we can integrate these two equations to find an expression for the free boson $X(z, \bar{z})$ which reads

$$X(z, \bar{z}) = x_0 - i \left(j_0 \ln z + \bar{j}_0 \ln \bar{z} \right) + i \sum_{n \neq 0} \frac{1}{n} \left(j_n z^{-n} + \bar{j}_n \bar{z}^{-n} \right). \quad (4.17)$$

Next, we require that under rotations $z \mapsto e^{2\pi i} z$ in the complex plane the field $X(z, \bar{z})$ is invariant, but now, up to the identifications (4.16) on the circle

$$X(e^{2\pi i} z, e^{-2\pi i} \bar{z}) = X(z, \bar{z}) + 2\pi R n.$$

Evaluating this relation for Eq. (4.17), we find that

$$j_0 - \bar{j}_0 = R n, \quad n \in \mathbb{Z},$$

which is in contrast to our result (2.90) for the original free boson. Thus, from this equation we infer that in general the ground state is non-trivially charged under j_0 and \bar{j}_0 which we write as

$$j_0 |\Delta, n\rangle = \Delta |\Delta, n\rangle, \quad \bar{j}_0 |\Delta, n\rangle = (\Delta - R n) |\Delta, n\rangle,$$

where Δ denotes the j_0 charge to be determined in the following. Because only the action of j_0 and \bar{j}_0 is changed, we can use our results from the previous section to calculate the partition function. We find

$$\begin{aligned} \mathcal{Z}_{\text{circ.}}(\tau, \bar{\tau}) &= \mathcal{Z}'_{\text{bos.}}(\tau, \bar{\tau}) \cdot \sum_{\Delta, n} \langle \Delta, n | q^{\frac{1}{2}j_0^2} \bar{q}^{\frac{1}{2}\bar{j}_0^2} | \Delta, n \rangle \\ &= \frac{1}{|\eta(\tau)|^2} \sum_{\Delta, n} q^{\frac{1}{2}\Delta^2} \bar{q}^{\frac{1}{2}(\Delta - R n)^2}, \end{aligned}$$

where it is understood that a sum is performed for discrete values of Δ whereas for continuous values one has to perform an integral.

However, as mentioned before, the partition function has to be invariant under modular transformations. In particular, for the modular T -transformation $T : \tau \mapsto \tau + 1$ we compute

$$\mathcal{Z}_{\text{circ.}}(\tau + 1, \bar{\tau} + 1) = \frac{1}{|\eta(\tau)|^2} \sum_{\Delta, n} q^{\frac{1}{2}\Delta^2} \bar{q}^{\frac{1}{2}(\Delta - Rn)^2} \cdot e^{2\pi i n \left(\Delta R - \frac{R^2 n}{2}\right)},$$

and by demanding modular invariance it follows that $\Delta = \frac{m}{R} + \frac{Rn}{2}$ where $m \in \mathbb{Z}$. We can then become more concrete about the action of j_0 and \bar{j}_0 on the ground state which now reads

$$j_0 |m, n\rangle = \left(\frac{m}{R} + \frac{Rn}{2}\right) |m, n\rangle, \quad \bar{j}_0 |m, n\rangle = \left(\frac{m}{R} - \frac{Rn}{2}\right) |m, n\rangle. \quad (4.18)$$

In string theory, states with $n \neq 0$ are called winding states because they correspond to strings winding n times around the circle given by $X(z, \bar{z})$. States with $m \neq 0$ are called momentum or Kaluza–Klein states because, as seen in Eq. (2.91), $\frac{j_0 + \bar{j}_0}{2}$ is the centre of mass momentum of the string which is quantised in a compact space. Finally,

The partition function of a single free boson compactified on a circle of radius R reads

$$\mathcal{Z}_{\text{circ.}}(\tau, \bar{\tau}) = \frac{1}{|\eta(\tau)|^2} \sum_{m, n} q^{\frac{1}{2}\left(\frac{m}{R} + \frac{Rn}{2}\right)^2} \bar{q}^{\frac{1}{2}\left(\frac{m}{R} - \frac{Rn}{2}\right)^2}. \quad (4.19)$$

Modular Forms II: Poisson Resummation Formula

We have already seen that the invariance of the partition function (4.19) under modular T -transformations is ensured by the transformation properties of $\eta(\tau)$ and by the requirement that $\frac{1}{2}(j_0 + \bar{j}_0) = \frac{m}{R}$ with $m \in \mathbb{Z}$. Proving the invariance under modular S -transformation is more involved and requires the following expression known as the Poisson resummation formula:

$$\sum_{n \in \mathbb{Z}} \exp(-\pi a n^2 + bn) = \frac{1}{\sqrt{a}} \sum_{k \in \mathbb{Z}} \exp\left(-\frac{\pi}{a} \left(k + \frac{b}{2\pi i}\right)^2\right). \quad (4.20)$$

This relation can be derived by using the discrete Fourier transform of the periodic function $\sum_n \delta(x - n)$

$$\sum_{n \in \mathbb{Z}} \delta(x - n) = \sum_{k \in \mathbb{Z}} e^{2\pi i k x}.$$

Employing this expression for the left-hand side of Eq. (4.20), we can write

$$\begin{aligned} \sum_{n \in \mathbb{Z}} \int_{-\infty}^{\infty} dx e^{-\pi a x^2 + bx} \delta(x - n) &= \sum_{k \in \mathbb{Z}} \int_{-\infty}^{\infty} dx e^{-\pi a x^2 + bx} e^{2\pi i k x} \\ &= \sum_{k \in \mathbb{Z}} \int_{-\infty}^{\infty} dx e^{-\frac{\pi}{a} \left(k + \frac{b}{2\pi i}\right)^2} e^{-\pi a \left(x - \frac{b}{2\pi a} - \frac{ik}{a}\right)^2} \\ &= \sum_{k \in \mathbb{Z}} e^{-\frac{\pi}{a} \left(k + \frac{b}{2\pi i}\right)^2} \frac{1}{\sqrt{a}}, \end{aligned}$$

where from the first to the second line we completed a perfect square in the exponent and from the second to the third line we performed a Gaussian integration². This proves the Poisson resummation formula (4.20).

In order to show that the partition function is invariant under a modular S -transformation

$$\mathcal{Z}_{\text{circ.}}\left(-\frac{1}{\tau}, -\frac{1}{\bar{\tau}}\right) = \mathcal{Z}_{\text{circ.}}(\tau, \bar{\tau}),$$

one has to employ the Poisson resummation formula twice. Since the calculation is straightforward, we will not present it here and leave it as an exercise.

Remarks

- Let us mention that the partition function (4.19) has an interesting property known as T-duality

$$\mathcal{Z}_{\text{circ.}}\left(\tau, \bar{\tau}, \frac{2}{R}\right) = \mathcal{Z}_{\text{circ.}}\left(\tau, \bar{\tau}, R\right). \tag{4.21}$$

For string theory, T-duality implies that a closed string propagating in a background space which is a circle cannot distinguish whether the size of the circle is R or $2/R$. Since $R = \sqrt{2}$ is a fixed point of Eq. (4.21), this self-dual radius can be interpreted as a minimal length scale a string can resolve.

- We can also investigate what are the allowed vertex operators for the theory of the free boson compactified on a circle of radius R . For a vertex operator to respect the symmetry of the theory, using Eq. (4.16) we have to demand

$$V_{\alpha} = : e^{i\alpha X(z, \bar{z})} : \stackrel{!}{=} : e^{i\alpha \left(X(z, \bar{z}) + 2\pi R n\right)} : = V_{\alpha} e^{2\pi i \alpha R n},$$

where $n \in \mathbb{Z}$. It therefore follows that

$$\alpha = \frac{m}{R} \quad \text{with } m \in \mathbb{Z}. \tag{4.22}$$

² The Gaussian integral $\int dx e^{-a(x+ib)}$ with imaginary offset can be evaluated using $\oint dz e^{-a(z+ib)} = 0, z \in \mathbb{C}$ with rectangular contour specified by $(-\infty, +\infty, +\infty + ib, -\infty + ib)$.

4.2.3 The Free Boson on a Circle of Radius $R = \sqrt{2k}$

In this section, we consider the theory of the free boson compactified on a circle with special values for the radius.

Partition Function

Let us study the partition function (4.19) for $R = \sqrt{2k}$ with $k \in \mathbb{Z}^+$. To do so, we start with chiral states which by definition have to satisfy

$$\bar{L}_0 |m, n\rangle = \bar{h} |m, n\rangle = \frac{1}{2} \left(\frac{m}{\sqrt{2k}} - \frac{\sqrt{2k}n}{2} \right)^2 |m, n\rangle = 0,$$

where we employed Eq. (4.18). A chiral state $|m, n\rangle$ is thus specified by $m = kn$. For the sum in the partition function (4.19), we then define

$$\sum_{m, n \in \mathbb{Z}} q^{\frac{1}{2} \left(\frac{m}{R} + \frac{Rn}{2} \right)^2} \bar{q}^{\frac{1}{2} \left(\frac{m}{R} - \frac{Rn}{2} \right)^2} \Big|_{\substack{m=kn \\ R=\sqrt{2k}}} = \sum_{n \in \mathbb{Z}} q^{kn^2} =: \Theta_{0,k}(\tau). \quad (4.23)$$

As we will see below, under a modular S -transformation the chiral part $\Theta_{0,k}(\tau)$ of the partition function transforms into a finite sum of more general $\Theta_{m,k}$ -functions defined as

$$\Theta_{m,k}(\tau) := \sum_{n \in \mathbb{Z} + \frac{m}{2k}} q^{kn^2}, \quad -k + 1 \leq m \leq k. \quad (4.24)$$

It thus directly follows from modular invariance that the partition function for one free boson on a circle of radius $R = \sqrt{2k}$ is expressed in terms of the finite set of $\Theta_{m,k}$ -functions. Indeed, referring to Eq. (4.19), it turns out that the partition function is written as

$$\mathcal{Z}_{\hat{u}(1)_k}(\tau, \bar{\tau}) = \frac{1}{|\eta(\tau)|^2} \sum_{m=-k+1}^k \left| \Theta_{m,k}(q) \right|^2, \quad (4.25)$$

which can be verified by using $R = \sqrt{2k}$ and rearranging the summation in Eq. (4.19). The conformal field theories corresponding to these partition functions are commonly denoted as $\hat{u}(1)_k$. Note, however, in view of our notation from Chap. 3, the level of an abelian Kač–Moody algebra does not have any invariant meaning as it can be changed by rescaling the generators. Therefore, the notation $\hat{u}(1)_k$ by definition denotes the CFT of one free boson compactified on circle of radius $R = \sqrt{2k}$.

In Sect. 3.3, we have studied the Kač–Moody algebra $\widehat{\mathfrak{su}}(2)_1$ which can be realised in terms of a free boson using the vertex operators $V_{\pm\sqrt{2}}$. Recalling Eq. (4.22), we see that such vertex operators are consistent with $X(z, \bar{z})$ compactified on a circle of radius $R = \frac{1}{\sqrt{2}}$. Employing then the T-duality relation stated in Eq. (4.21), we see that (the partition function of) $\widehat{\mathfrak{su}}(2)_1$ can be realised by one free boson compactified on a circle of radius $R = \sqrt{2}$. And indeed, using $k = 1$ in Eq. (4.25) we find

$$\mathcal{Z}_{\widehat{\mathfrak{su}}(2)_1}(\tau, \bar{\tau}) = \frac{1}{|\eta(\tau)|^2} \left(|\Theta_{0,1}|^2 + |\Theta_{1,1}|^2 \right), \tag{4.26}$$

which contains the two generating functions shown in Eqs. (3.13) and (3.14) for the two irreducible representations of $\widehat{\mathfrak{su}}(2)_1$.

Definition of Characters

The example above illustrates the fact that the partition function of a Rational conformal field theory can be expressed in terms of the generating functions of the highest weight representations of the underlying chiral algebra. This motivates the following definition which will be important for studying modular invariant partition functions:

Definition 1. *The character of an irreducible representation $|h_i\rangle$ with highest weight h_i is defined as*

$$\chi_i(\tau) := \text{Tr}_{\mathcal{H}_i} \left(q^{L_0 - \frac{c}{24}} \right), \tag{4.27}$$

where \mathcal{H}_i denotes the Hilbert space built upon the (irreducible) highest weight state $|h_i\rangle$.

This definition, together with our observation in Eq. (4.23), allows us to write Eq. (4.26) as

$$\mathcal{Z}_{\widehat{\mathfrak{su}}(2)_1}(\tau, \bar{\tau}) = |\chi_0^{(1)}|^2 + |\chi_1^{(1)}|^2 \quad \text{where} \quad \chi_m^{(1)} = \frac{\Theta_{m,1}(\tau)}{\eta(\tau)}. \tag{4.28}$$

Modular Forms III: Modular Transformations of the Θ -Functions

As we have seen for instance in Eq. (4.26) and used in Eq. (4.25), partition functions are expressed in terms of Θ -functions. Therefore, it is important to know their behaviour under modular transformations which we will study now.

For the T -transformation $T : \tau \mapsto \tau + 1$, using the definition (4.24) it is straightforward to compute

$$\Theta_{m,k}(\tau + 1) = e^{\pi i \frac{m^2}{2k}} \Theta_{m,k}(\tau) .$$

However, the modular S -transformation $S : \tau \mapsto -\frac{1}{\tau}$ is more involved. To determine its form, we write out the expression for the transformed $\Theta_{m,k}$ -function and employ (the opposite direction of) the Poisson resummation formula (4.20) with $a = \frac{\tau}{2ki}$ and $b = 2\pi i \frac{m}{2k}$

$$\begin{aligned} \Theta_{m,k}\left(-\frac{1}{\tau}\right) &= \sum_{n \in \mathbb{Z}} \exp\left(-\frac{2\pi i k}{\tau} \left(n + \frac{m}{2k}\right)^2\right) \\ &= \sqrt{\frac{-i\tau}{2k}} \sum_{n' \in \mathbb{Z}} \exp\left(2\pi i \tau k \left(\frac{n'}{2k}\right)^2 + \pi i \frac{n' m}{k}\right). \end{aligned}$$

Substituting then $n' = -(2kn + m')$ and summing over $n \in \mathbb{Z}$ and $m' = -k + 1, \dots, k$, we find for the expression above

$$\Theta_{m,k}\left(-\frac{1}{\tau}\right) = \sqrt{\frac{-i\tau}{2k}} \sum_{n \in \mathbb{Z}} \sum_{m' = -k+1}^k \exp\left(2\pi i \tau k \left(n + \frac{m'}{2k}\right)^2 - \pi i \frac{m' m}{k}\right).$$

Introducing a new notation, we can summarise that

The modular S -transformation of the Θ -functions takes the following form:

$$\Theta_{m,k}\left(-\frac{1}{\tau}\right) = \sqrt{-i\tau} \sum_{m' = -k+1}^k S_{m,m'} \Theta_{m',k}(\tau), \quad (4.29)$$

with the definition of the modular S -matrix

$$S_{m,m'} = \frac{1}{\sqrt{2k}} \exp\left(-\pi i \frac{m m'}{k}\right). \quad (4.30)$$

Note that in general, the matrix S does not square to the identity matrix but

$$S^2 = C \quad \text{with} \quad C^2 = 1. \quad (4.31)$$

This is not in conflict with Eq. (4.8) since here we are considering characters and not modular parameters. The matrix C is called the charge conjugation matrix and maps representations i to the charge conjugate representation i^+ denoted by $+$ in the following.

Modular Invariance of the Partition Function Revisited

Let us now study the modular invariance of Eq. (4.28) respectively Eq. (4.26) from a different perspective. Of course, as shown in the beginning of the previous sub-

section, a partition function of the form (4.19) is always invariant under modular T - and S -transformations. However, Eq. (4.28) serves as an example for more general theories.

The modular S -transformation of the characters defined in Eq. (4.28) can be inferred from the transformation properties of the Θ - and η -functions to be of the form

$$\chi_m^{(1)} = \sum_{m'=0}^1 S_{m,m'} \chi_{m'}^{(1)} \quad \text{with} \quad S_{m,m'} = \frac{1}{\sqrt{2}} \begin{pmatrix} 1 & 1 \\ 1 & -1 \end{pmatrix} .$$

Furthermore, we observe that the partition function (4.28) can be written as

$$\mathcal{Z}_{\widehat{u}(1)_1}(\tau, \bar{\tau}) = (\chi_0^{(1)}, \chi_1^{(1)}) \begin{pmatrix} 1 & 0 \\ 0 & 1 \end{pmatrix} \begin{pmatrix} \bar{\chi}_0^{(1)} \\ \bar{\chi}_1^{(1)} \end{pmatrix} = \vec{\chi}^T M \vec{\bar{\chi}} ,$$

where M in the present case is the identity matrix. Writing the modular S -transformation as a matrix multiplication, we find

$$\mathcal{Z}_{\widehat{u}(1)_1} \left(-\frac{1}{\tau}, -\frac{1}{\bar{\tau}} \right) = \vec{\chi}^T S^T M S^* \vec{\bar{\chi}} ,$$

where S^* denotes the complex conjugate of S . Since S is symmetric, that is, $S^T = S$ (see the definition (4.30)), the condition for invariance under modular S -transformations for the partition function above reads

$$S M S^\dagger = M , \tag{4.32}$$

which is of course satisfied in our present example. Because under T -transformations the characters $\chi_m^{(1)}$ only acquire a phase, we have shown in a somewhat more abstract way that the partition function $\mathcal{Z}_{\widehat{u}(1)_1}(\tau, \bar{\tau})$ is modular invariant.

By the same arguments as for the case $k = 1$, a modular invariant partition function for arbitrary k can be written as

$$\boxed{\mathcal{Z}_{\widehat{u}(1)_k}(\tau, \bar{\tau}) = \sum_{m=-k+1}^k |\chi_m^{(k)}|^2 \quad \text{with} \quad \chi_m^{(k)} = \frac{\Theta_{m,k}(\tau)}{\eta(\tau)} .} \tag{4.33}$$

However, in more general situations where M is not the identity matrix, clearly not all choices of M satisfy Eq. (4.32). Thus, modular invariance imposes strong conditions on the couplings of the left- and right-moving sector in a partition function.

Remark

Let us take a closer look at the characters of $\widehat{u}(1)_k$ and employ the definitions of $\eta(\tau)$ and $\Theta_{m,k}(\tau)$ to expand $\chi_m^{(k)}$ in the following way:

$$\begin{aligned}\chi_m^{(k)} &= \frac{\Theta_{m,k}(\tau)}{\eta(\tau)} = q^{-\frac{1}{24}} \prod_{l=0}^{\infty} \sum_{N_l=0}^{\infty} q^{l N_l} \sum_{n \in \mathbb{Z} + \frac{m}{2k}} q^{k n^2} \\ &= q^{-\frac{1}{24}} \left(q^{\frac{m^2}{4k}} + q^{\frac{m^2}{4k} + 1} + \dots \right).\end{aligned}$$

By comparing with the definition (4.27) of a character and keeping in mind that for the free boson the central charge is $c = 1$, we see that the lowest L_0 eigenvalue is $\frac{m^2}{4k}$. Therefore, the highest weight state corresponding to the $\widehat{u}(1)_k$ character $\chi_m^{(k)}$ has conformal dimension

$$h = \frac{m^2}{4k}. \quad (4.34)$$

4.2.4 The Free Fermion

Besides the free boson, the CFT of a free fermion is the other main building block for most string theory applications of conformal field theory. Therefore, let us also quite explicitly work out the corresponding partition function. Here, modular invariance will be our main guiding principle from which the necessity of the GSO projection and the introduction of various boundary conditions (Neveu–Schwarz and Ramond) directly follow.

Computation of the Character

We first consider a free fermion $\psi(z)$ in the Neveu–Schwarz sector with mode expansion

$$\psi(z) = \sum_{r \in \mathbb{Z} + \frac{1}{2}} \psi_r z^{-r - \frac{1}{2}}.$$

Note that on the torus with variable w , this corresponds to anti-periodic boundary conditions. States in the Fock space \mathcal{F} of this theory are obtained by acting with creation operators ψ_{-s} on the vacuum $|0\rangle$

$$|n_{\frac{1}{2}}, n_{\frac{3}{2}}, n_{\frac{5}{2}}, \dots\rangle = (\psi_{-\frac{1}{2}})^{n_{\frac{1}{2}}} (\psi_{-\frac{3}{2}})^{n_{\frac{3}{2}}} (\psi_{-\frac{5}{2}})^{n_{\frac{5}{2}}} \dots |0\rangle, \quad n_s = 0, 1.$$

Next, from Eq. (2.111) in Sect. 2.9.2, we recall the form of the energy–momentum tensor and write it in the present case as

$$L_0 = \sum_{s=\frac{1}{2}}^{\infty} s \psi_{-s} \psi_s ,$$

where the sum is over half-integer $s = \frac{1}{2}, \frac{3}{2}, \dots$. The action of L_0 on a general state in the Fock space \mathcal{F} is then computed using the anti-commutation relation $\{\psi_r, \psi_s\} = \delta_{r,-s}$ for fermions

$$\begin{aligned} L_0 |n_{\frac{1}{2}}, n_{\frac{3}{2}}, \dots\rangle &= L_0 (\psi_{-\frac{1}{2}})^{n_{\frac{1}{2}}} (\psi_{-\frac{3}{2}})^{n_{\frac{3}{2}}} \dots |0\rangle \\ &= \sum_{s=\frac{1}{2}}^{\infty} s (\psi_{-\frac{1}{2}})^{n_{\frac{1}{2}}} \dots n_s (\psi_{-s} \psi_s \psi_{-s}) \dots |0\rangle \\ &= \sum_{s=\frac{1}{2}}^{\infty} s n_s |n_{\frac{1}{2}}, n_{\frac{3}{2}}, \dots\rangle . \end{aligned}$$

Using this expression, it is easy to compute the following character:

$$\begin{aligned} \chi_{\text{NS},+}(\tau) &= \text{Tr}_{\mathcal{F}} \left(q^{L_0 - \frac{c}{24}} \right) \\ &= q^{-\frac{1}{48}} \sum_{n_{\frac{1}{2}}=0}^1 \sum_{n_{\frac{3}{2}}=0}^1 \sum_{n_{\frac{5}{2}}=0}^1 \dots \langle n_{\frac{1}{2}}, n_{\frac{3}{2}}, n_{\frac{5}{2}}, \dots | q^{L_0} | n_{\frac{1}{2}}, n_{\frac{3}{2}}, n_{\frac{5}{2}}, \dots \rangle \\ &= q^{-\frac{1}{48}} \sum_{n_{\frac{1}{2}}=0}^1 \sum_{n_{\frac{3}{2}}=0}^1 \sum_{n_{\frac{5}{2}}=0}^1 \dots \left(q^{\frac{1}{2} \cdot n_{\frac{1}{2}}} \cdot q^{\frac{3}{2} \cdot n_{\frac{3}{2}}} \cdot q^{\frac{5}{2} \cdot n_{\frac{5}{2}}} \cdot \dots \right) \\ &= q^{-\frac{1}{48}} \left(1 + q^{\frac{1}{2}} \right) \cdot \left(1 + q^{\frac{3}{2}} \right) \cdot \left(1 + q^{\frac{5}{2}} \right) \cdot \dots \tag{4.35} \\ &= q^{-\frac{1}{48}} \prod_{r=0}^{\infty} \left(1 + q^{r+\frac{1}{2}} \right) =: \sqrt{\frac{\vartheta_3(\tau)}{\eta(\tau)}} , \end{aligned}$$

where the ellipses again indicate that there are infinitely many sums respectively infinitely many factors in the products. Furthermore, we introduced a new modular function denoted as $\vartheta_3(\tau)$ which takes the form

$$\vartheta_3(\tau) = \eta(\tau) q^{-\frac{1}{24}} \prod_{r=0}^{\infty} \left(1 + q^{r+\frac{1}{2}} \right) \left(1 + q^{r+\frac{1}{2}} \right) = \sum_{n \in \mathbb{Z}} q^{\frac{n^2}{2}} . \tag{4.36}$$

The first part in Eq. (4.36) is the representation of ϑ_3 as an infinite product while the second part gives a representation as an infinite sum. This equality is not obvious but we will prove it in the following.

Modular Forms IV: Jacobi Triple Product Identity

To do so, let us recall our discussion about complex fermions and bosonisation from p. 63. In particular, we have seen that the algebra generated by two fermions $\Psi(z)$ and $\bar{\Psi}(z)$ in the NS sector with j_0 eigenvalues ± 1 is equivalent to the algebra generated by

$$j(z) = i \partial X(z, \bar{z}), \quad j^\pm(z) = V_{\pm 1}(z) = : e^{\pm iX} : . \quad (4.37)$$

Using Eq. (4.22), we observe that the vertex operators in Eq. (4.37) correspond to a free boson compactified on a circle of radius $R = 1$. Therefore, besides the fields in Eq. (4.37) the remaining primary fields for such a theory are given by the vertex operators

$$V_{\pm N}(z) = : e^{\pm i N X} : \quad \text{with} \quad (h, \alpha) = \left(\frac{N^2}{2}, N \right), \quad N \in \mathbb{Z},$$

where h is the conformal weight of V_α and α denotes the j_0 charge of the vertex operator.

Let us next consider a charged character $\chi(\tau, z)$ which contains the information not only about the conformal weight h but also about the j_0 charge. The definition reads as follows:

$$\chi(\tau, z) = \text{Tr}_{\mathcal{H}_i} \left(q^{L_0 - \frac{c}{24}} w^{j_0} \right) \quad \text{with} \quad w = \exp(2\pi i z). \quad (4.38)$$

For the two complex fermions $\Psi(z)$ and $\bar{\Psi}(z)$, the charged character is computed following the same steps as in Eq. (4.35) with the (anti-)commutation relations (2.114) taken into account. Since the Hilbert spaces of $\Psi(z)$ and $\bar{\Psi}(z)$ are independent of each other, one finds

$$\chi_{(\Psi, \bar{\Psi})}(\tau, z) = q^{-\frac{1}{24}} \prod_{r \geq 0} (1 + q^{r+\frac{1}{2}} w) (1 + q^{r+\frac{1}{2}} w^{-1}). \quad (4.39)$$

For the theory of the boson compactified on a circle of radius $R = 1$, we have the character corresponding to the primary field $j(z)$ leading to the familiar result

$$\chi_{(0)}(\tau, z) = \frac{1}{\eta(\tau)} .$$

Here, there is no dependence on z since j_0 commutes with all j_n and annihilates the vacuum. For the characters corresponding to the primary fields V_α with $(h, \alpha) = (\frac{N^2}{2}, N)$, let us note that the states in the Hilbert space can be written as

$$|\alpha, n_1, n_2, n_3, \dots\rangle = \lim_{z, \bar{z} \rightarrow 0} j_{-1}^{n_1} j_{-2}^{n_2} j_{-3}^{n_3} \dots V_\alpha(z, \bar{z}) |0\rangle ,$$

with $n_i \geq 0$. Using our results from Sect. 2.9.1, the action of L_0 and j_0 on such states is determined to be of the following form:

$$\begin{aligned}
 L_0 |\alpha, n_1, n_2, n_3, \dots\rangle &= \lim_{z, \bar{z} \rightarrow 0} \left(\sum_{k \geq 1} k n_k j_{-1}^{n_1} j_{-2}^{n_2} j_{-3}^{n_3} \dots + L_0 \right) V_\alpha(z, \bar{z}) |0\rangle \\
 &= \left(\sum_{k \geq 1} k n_k + \frac{\alpha^2}{2} \right) |\alpha, n_1, n_2, n_3, \dots\rangle. \\
 j_0 |\alpha, n_1, n_2, n_3, \dots\rangle &= \lim_{z, \bar{z} \rightarrow 0} j_{-1}^{n_1} j_{-2}^{n_2} j_{-3}^{n_3} \dots j_0 V_\alpha(z, \bar{z}) |0\rangle \\
 &= \alpha |\alpha, n_1, n_2, n_3, \dots\rangle.
 \end{aligned}$$

Using these results and following the same steps as in the calculation on p. 121, one arrives at

$$\chi_{(\alpha)}(\tau, z) = \text{Tr}_{\mathcal{H}_\alpha} \left(q^{L_0 - \frac{c}{24}} w^{j_0} \right) = \frac{1}{\eta(\tau)} q^{\frac{\alpha^2}{2}} w^\alpha.$$

Employing again Eq. (4.22), the sum of all characters for the theory of the free boson compactified on a circle of radius R then reads

$$\chi(\tau, z) = \sum_\alpha \chi_{(\alpha)}(\tau, z) = \frac{1}{\eta(\tau)} \sum_{N \in \mathbb{Z}} q^{\frac{N^2}{2R^2}} w^{\frac{N}{R}}.$$

Due to bosonisation described above, for $R = 1$ this expression has to be equal to Eq. (4.39). We have therefore established the relation

$$\boxed{q^{-\frac{1}{24}} \prod_{r \geq 0} (1 + q^{r+\frac{1}{2}} w) (1 + q^{r+\frac{1}{2}} w^{-1}) = \frac{1}{\eta(\tau)} \sum_{N \in \mathbb{Z}} q^{\frac{N^2}{2}} w^N}, \quad (4.40)$$

which is called the Jacobi triple product identity. Using finally Eq. (4.40) with $w = 1$ yields exactly Eq. (4.36).

Turning our argument of this paragraph around, the mathematically well-known Jacobi triple product identity in conformal field theory reflects nothing else than the Bose–Fermi correspondence.

Modular Transformations of the Character

The character $\chi_{\text{NS},+}(\tau)$ we have computed in Eq. (4.35) is part of the partition function of a free fermion in the Neveu–Schwarz sector. Since we want to construct a modular invariant partition function, we have to study the modular properties of

$\chi_{\text{NS},+}(\tau)$. In particular, the character is not invariant under modular transformations but new terms are generated.

1. As we have observed previously, the modular T -transformation is achieved simply by replacing $q \mapsto e^{2\pi i} q$ which leads to

$$T(\chi_{\text{NS},+}(\tau)) = e^{-\frac{i\pi}{24}} q^{-\frac{1}{48}} \prod_{r \geq 0} (1 - q^{r+\frac{1}{2}}) =: e^{-\frac{i\pi}{24}} \sqrt{\frac{\vartheta_4(\tau)}{\eta(\tau)}}, \quad (4.41)$$

where we have defined a new modular function denoted as ϑ_4 . Writing out this definition and using the Jacobi triple product identity (4.40) with $w = -1$, we find

$$\vartheta_4(\tau) = \eta(\tau) q^{-\frac{1}{24}} \prod_{r=0}^{\infty} (1 - q^{r+\frac{1}{2}}) (1 - q^{r+\frac{1}{2}}) = \sum_{n \in \mathbb{Z}} (-1)^n q^{\frac{n^2}{2}}.$$

Next, we introduce the fermion number operator f via the anti-commutation relation $\{(-1)^f, \psi_r\} = 0$ and define a new character $\chi_{\text{NS},-}(\tau)$ as

$$\chi_{\text{NS},-}(\tau) = \text{Tr}_{\mathcal{F}} \left((-1)^f q^{L_0 - \frac{c}{24}} \right) = \sqrt{\frac{\vartheta_4(\tau)}{\eta(\tau)}}, \quad (4.42)$$

where the final result is obtained by performing a computation along the same lines as in Eq. (4.35). Note that the new character is (up to a phase) the T -transform of $\chi_{\text{NS},+}(\tau)$.

2. For the modular S -transformation of our first character $\chi_{\text{NS},+}(\tau)$, let us focus first only on $\vartheta_3(\tau)$ for which we find

$$\vartheta_3\left(-\frac{1}{\tau}\right) = \sum_{n \in \mathbb{Z}} e^{-\frac{2\pi i}{\tau} \frac{n^2}{2}} \stackrel{(4.20)}{=} \sqrt{-i\tau} \sum_{m \in \mathbb{Z}} e^{i\pi\tau m^2} = \sqrt{-i\tau} \vartheta_3(\tau),$$

where we employed the Poisson resummation formula (4.20) with $a = \frac{i}{\tau}$ and $b = 0$. Since the η -function transforms as $S : \eta(\tau) \mapsto \sqrt{-i\tau} \eta(\tau)$, we see that $\chi_{\text{NS},+}(\tau)$ is invariant under modular S -transformations

$$S(\chi_{\text{NS},+}(\tau)) = \chi_{\text{NS},+}(\tau).$$

3. So far, we have determined how the character $\chi_{\text{NS},+}(\tau)$ transforms under S and T . However, in order to construct a modular invariant partition function, we also need to know the modular transformations of $\chi_{\text{NS},-}(\tau)$ displayed in Eq. (4.42). To this end, we calculate for the S -transformation

$$\vartheta_4\left(-\frac{1}{\tau}\right) = \sum_{n \in \mathbb{Z}} e^{-\frac{\pi i}{\tau} n^2 + \pi i n} \stackrel{(4.40)}{=} \sqrt{-i\tau} \sum_{m \in \mathbb{Z}} e^{i\pi\tau(m+\frac{1}{2})^2} = \sqrt{-i\tau} \vartheta_2(\tau),$$

where we used again the Poisson resummation formula with $a = \frac{i}{\tau}$ and $b = \pi i$. Furthermore, we have yet defined another modular function as

$$\vartheta_2(\tau) = \sum_{m \in \mathbb{Z}} q^{\frac{1}{2}(m+\frac{1}{2})^2}.$$

Since for the other ϑ -functions we found a product representation, we expect a similar expression also for ϑ_2 . And indeed, choosing $w = q^{\frac{1}{2}}$ in Eq. (4.40) leads to

$$\begin{aligned} q^{-\frac{1}{24}} \prod_{r \geq 0} (1 + q^{r+1})(1 + q^r) &= \frac{1}{\eta(\tau)} \sum_{n \in \mathbb{Z}} q^{\frac{n^2}{2} + \frac{n}{2}} \\ 2q^{-\frac{1}{24}} \prod_{r \geq 1} (1 + q^r)^2 &= \frac{1}{\eta(\tau)} \sum_{n \in \mathbb{Z}} q^{\frac{1}{2}(n+\frac{1}{2})^2 - \frac{1}{8}}, \end{aligned}$$

from which we conclude that

$$\vartheta_2(\tau) = \eta(\tau) 2q^{\frac{1}{12}} \prod_{r \geq 1} (1 + q^r)^2 = \sum_{n \in \mathbb{Z}} q^{\frac{1}{2}(n+\frac{1}{2})^2}.$$

We summarise the modular S -transformation of the character (4.42) and define a new character as

$$\chi_{R,+}(\tau) = S(\chi_{NS,-}(\tau)) = \sqrt{2} q^{\frac{1}{24}} \prod_{r \geq 1} (1 + q^r) = \sqrt{\frac{\vartheta_2(\tau)}{\eta(\tau)}}. \quad (4.43)$$

Note that here the exponent of q takes integer values r which indicates that this is a partition function for fermions ψ_r with $r \in \mathbb{Z}$, that is, for fermions in the Ramond sector.

- Finally, we still have to perform a modular T -transformation on the character (4.42) and a T - and S -transformation on Eq. (4.43). Without going into detail, we just state the results which are easily verified

$$\begin{aligned} T(\chi_{NS,-}(\tau)) &= e^{-\frac{i\pi}{24}} \chi_{NS,+}(\tau), \quad T(\chi_{R,+}(\tau)) = e^{\frac{i\pi}{12}} (\chi_{R,+}(\tau)), \\ S(\chi_{R,+}(\tau)) &= \chi_{NS,-}(\tau). \end{aligned}$$

The Partition Function

In the last paragraph we have computed the various modular transformations of the character (4.35) from which we now can construct a modular invariant partition

function. In particular, starting from a free fermion in the Neveu–Schwarz sector, we have seen that modular invariance requires us to also take the Ramond sector into account as well as the operator $(-1)^f$. Concretely, the partition function is written as

$$\mathcal{Z}_{\text{ferm.}}(\tau, \bar{\tau}) = \frac{1}{2} \left(\left| \frac{\vartheta_3}{\eta} \right| + \left| \frac{\vartheta_4}{\eta} \right| + \left| \frac{\vartheta_2}{\eta} \right| \right), \quad (4.44)$$

where we have indicated how the modular T - and S -transformations interchange the various terms. The overall factor of $1/2$ is necessary to ensure that the non-degenerate Neveu–Schwarz ground state only appears once. This factor cancels against the $\sqrt{2}$ factor appearing in $\sqrt{\vartheta_2/\eta}$, so that the Ramond ground state (for a single free fermion) is also non-degenerate.

However, we have seen that it is convenient to express partition functions in terms of characters. Although not explicitly needed in the following, to this end we define

$$\begin{aligned} \chi_0 &= \frac{1}{2} \left(\sqrt{\frac{\vartheta_3}{\eta}} + \sqrt{\frac{\vartheta_4}{\eta}} \right) = \text{Tr}_{\text{NS}} \left(\frac{1 + (-1)^f}{2} q^{L_0 - \frac{c}{24}} \right), \\ \chi_{\frac{1}{2}} &= \frac{1}{2} \left(\sqrt{\frac{\vartheta_3}{\eta}} - \sqrt{\frac{\vartheta_4}{\eta}} \right) = \text{Tr}_{\text{NS}} \left(\frac{1 - (-1)^f}{2} q^{L_0 - \frac{c}{24}} \right), \\ \chi_{\frac{1}{16}} &= \frac{1}{\sqrt{2}} \sqrt{\frac{\vartheta_2}{\eta}} = \text{Tr}_{\text{R}} \left(q^{L_0 - \frac{c}{24}} \right), \end{aligned} \quad (4.45)$$

where the subscripts indicate the conformal weight of the highest weight representations and the traces are over states in the Neveu–Schwarz respectively Ramond sector. Using these expressions, we can write the partition function (4.44) for a single free fermion as

$$\mathcal{Z}_{\text{ferm.}}(\tau, \bar{\tau}) = \chi_0 \bar{\chi}_0 + \chi_{\frac{1}{2}} \bar{\chi}_{\frac{1}{2}} + \chi_{\frac{1}{16}} \bar{\chi}_{\frac{1}{16}}. \quad (4.46)$$

Remarks

- Note that Eq. (4.46) is the partition function of the Ising model introduced in Sect. 2.10.
- The structure of the free fermion partition function also appears when studying the superstring in flat backgrounds. There, the projection given by the operator $\frac{1}{2}(1 + (-1)^f)$ is known as the Gliozzi–Scherk–Olive (GSO) projection.

Modular Forms V: The ϑ -Functions

In this paragraph, let us briefly summarise and extend our findings about the ϑ -functions introduced previously. For this purpose, we define

$$\vartheta \left[\begin{smallmatrix} \alpha \\ \beta \end{smallmatrix} \right] (\tau, z) = \sum_{n \in \mathbb{Z}} q^{\frac{1}{2}(n+\alpha)^2} e^{2\pi i(n+\alpha)(z+\beta)},$$

which can be shown to also have a representation as an infinite product

$$\frac{\vartheta \left[\begin{smallmatrix} \alpha \\ \beta \end{smallmatrix} \right] (\tau, z)}{\eta(\tau)} = e^{2\pi i\alpha(z+\beta)} q^{\frac{\alpha^2}{2} - \frac{1}{24}} \prod_{n=1}^{\infty} \left(1 + q^{n+\alpha-\frac{1}{2}} e^{2\pi i(z+\beta)} \right) \left(1 + q^{n-\alpha-\frac{1}{2}} e^{-2\pi i(z+\beta)} \right).$$

The ϑ_2 -, ϑ_3 - and ϑ_4 -functions can then be expressed as

$$\begin{aligned} \vartheta_1(\tau) &= \vartheta \left[\begin{smallmatrix} 1/2 \\ 1/2 \end{smallmatrix} \right] (\tau, 0) \equiv 0, \\ \vartheta_2(\tau) &= \vartheta \left[\begin{smallmatrix} 1/2 \\ 0 \end{smallmatrix} \right] (\tau, 0) = \sum_{n \in \mathbb{Z}} q^{\frac{1}{2}(n+\frac{1}{2})^2} = \eta(\tau) 2 q^{\frac{1}{24}} \prod_{r=1}^{\infty} (1 + q^r)^2, \\ \vartheta_3(\tau) &= \vartheta \left[\begin{smallmatrix} 0 \\ 0 \end{smallmatrix} \right] (\tau, 0) = \sum_{n \in \mathbb{Z}} q^{\frac{n^2}{2}} = \eta(\tau) q^{-\frac{1}{24}} \prod_{r=0}^{\infty} (1 + q^{r+\frac{1}{2}})^2, \\ \vartheta_4(\tau) &= \vartheta \left[\begin{smallmatrix} 0 \\ 1/2 \end{smallmatrix} \right] (\tau, 0) = \sum_{n \in \mathbb{Z}} (-1)^n q^{\frac{n^2}{2}} = \eta(\tau) q^{-\frac{1}{24}} \prod_{r=0}^{\infty} (1 - q^{r+\frac{1}{2}})^2, \end{aligned}$$

where for completeness we introduced ϑ_1 which, however, vanishes identically. For the modular transformations, we simply state that

$$\begin{aligned} \vartheta \left[\begin{smallmatrix} \alpha \\ \beta \end{smallmatrix} \right] (\tau + 1, z) &= e^{-i\pi\alpha(\alpha-1)} \vartheta \left[\begin{smallmatrix} \alpha \\ \alpha+\beta-1/2 \end{smallmatrix} \right] (\tau, z), \\ \vartheta \left[\begin{smallmatrix} \alpha \\ \beta \end{smallmatrix} \right] \left(-\frac{1}{\tau}, \frac{z}{\tau} \right) &= \sqrt{-i\tau} e^{2\pi i\alpha\beta+i\pi\frac{z^2}{\tau}} \vartheta \left[\begin{smallmatrix} \beta \\ -\alpha \end{smallmatrix} \right] (\tau, z), \end{aligned}$$

from which we find

$$\begin{array}{ll}
 \vartheta_1(\tau + 1) = e^{\frac{\pi i}{4}} \vartheta_1(\tau) , & \vartheta_1\left(-\frac{1}{\tau}\right) = e^{\frac{\pi i}{2}} \sqrt{-i\tau} \vartheta_1(\tau) , \\
 \vartheta_2(\tau + 1) = e^{\frac{\pi i}{4}} \vartheta_2(\tau) , & \vartheta_2\left(-\frac{1}{\tau}\right) = \sqrt{-i\tau} \vartheta_4(\tau) , \\
 \vartheta_3(\tau + 1) = \vartheta_4(\tau) , & \vartheta_3\left(-\frac{1}{\tau}\right) = \sqrt{-i\tau} \vartheta_3(\tau) , \\
 \vartheta_4(\tau + 1) = \vartheta_3(\tau) , & \vartheta_4\left(-\frac{1}{\tau}\right) = \sqrt{-i\tau} \vartheta_2(\tau) .
 \end{array}$$

Modular Forms VI: S-Transformation of the η -function

Finally, using the ϑ -functions it is a simple exercise to determine the behaviour of the Dedekind η -function under modular transformations. Let us compute

$$\begin{aligned}
 \sqrt{\frac{\vartheta_3 \vartheta_4 \vartheta_2}{2 \eta^3}} &= \prod_{n=1}^{\infty} (1 + q^{n-\frac{1}{2}})(1 - q^{n-\frac{1}{2}})(1 + q^n) \\
 &= \prod_{n=1}^{\infty} (1 - q^{2n-1})(1 + q^n) \\
 &= \prod_{n=1}^{\infty} \frac{(1 - q^n)}{(1 - q^{2n})} (1 + q^n) \\
 &= 1 ,
 \end{aligned}$$

from which we can infer the modular properties of $\eta(\tau)$ using the transformations of the ϑ -functions. In particular, we find

$$\eta(\tau + 1) = e^{\frac{\pi i}{12}} \eta(\tau) , \quad \eta\left(-\frac{1}{\tau}\right) = \sqrt{-i\tau} \eta(\tau) ,$$

which proves Eq. (4.15).

4.2.5 The Free Boson Orbifold

In string theory, one is interested in describing strings moving in a compact background manifold. One of the simplest example is the free boson on a circle studied in Sect. 4.2.2, however, usually more involved constructions are needed. In general, an exact CFT description of curved backgrounds is very complicated, but there exists a

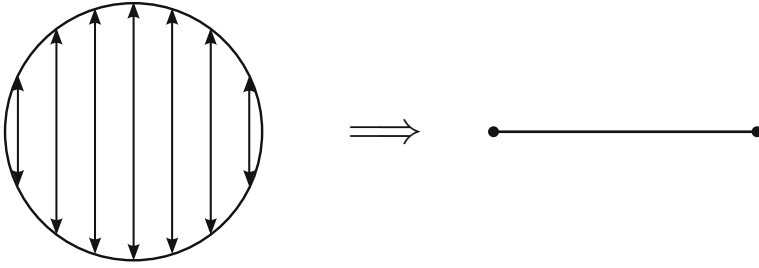

Fig. 4.4 Illustration of the \mathbb{Z}_2 -orbifold of the circle. Effectively, the circle becomes a line with a fixed point at each end

construction which, though being a quotient of a torus, nevertheless captures some of the features of genuine compactifications on highly curved background geometries. These are the so-called orbifold models which we are going to study in this section.

Concretely, we consider the \mathbb{Z}_2 -orbifold of the free boson on the circle. Here, we not only perform the identification of the circle $X \sim X + 2\pi R$, but we also impose a \mathbb{Z}_2 symmetry \mathcal{R} acting as

$$\mathcal{R} : X(z, \bar{z}) \mapsto -X(z, \bar{z}) .$$

As illustrated in Fig. 4.4, this amounts to identifying the fields $X(z, \bar{z})$ and $-X(z, \bar{z})$ which means that effectively the circle becomes a line with a fixed point at each end.

Calculation of the Partition Function

For conformal field theories on orbifolds, in general the Hilbert space will be changed compared to the original theory. In particular, the Hilbert space contains only states which are invariant under the orbifold action and for the calculation of the partition function, one therefore projects onto invariant states. In the present case, the orbifold action is \mathcal{R} and the projector reads $\frac{1}{2}(1 + \mathcal{R})$ for which we find

$$\begin{aligned} \mathcal{Z}(\tau, \bar{\tau}) &= \text{Tr}_{\mathcal{H}} \left(\frac{1 + \mathcal{R}}{2} q^{L_0 - \frac{c}{24}} \bar{q}^{\bar{L}_0 - \frac{c}{24}} \right) \\ &= \frac{1}{2} \mathcal{Z}_{\text{circ.}}(\tau, \bar{\tau}) + \frac{1}{2} \text{Tr}_{\mathcal{H}} \left(\mathcal{R} q^{L_0 - \frac{c}{24}} \bar{q}^{\bar{L}_0 - \frac{c}{24}} \right) . \end{aligned} \tag{4.47}$$

The first term contains the partition function of the free boson on the circle which we already computed in Eq. (4.19). Let us therefore focus on the second term. The action of \mathcal{R} on the Laurent modes j_n of the current $j(z) = i \partial X(z, \bar{z})$ is easily found to be $\mathcal{R} j_n \mathcal{R} = -j_n$ and similarly for the anti-holomorphic part. From this we can infer the action on a general state defined in Eq. (4.12) as

$$\begin{aligned} \mathcal{R} |n_1, n_2, n_3, \dots\rangle &= (\mathcal{R} j_{-1} \mathcal{R})^{n_1} (\mathcal{R} j_{-2} \mathcal{R})^{n_2} \dots \mathcal{R} |0\rangle \\ &= (-1)^{n_1+n_2+n_3+\dots} |n_1, n_2, n_3, \dots\rangle, \end{aligned} \quad (4.48)$$

where we have chosen the action of \mathcal{R} such that $|0\rangle$ is left invariant. For the momentum and winding states $|m, n\rangle$ introduced in Eq. (4.18), we calculate

$$j_0 \mathcal{R} |m, n\rangle = \mathcal{R} (\mathcal{R} j_0 \mathcal{R}) |m, n\rangle = \mathcal{R} (-j_0) |m, n\rangle = -\left(\frac{m}{R} + \frac{Rn}{2}\right) \mathcal{R} |m, n\rangle,$$

and similarly for \bar{j}_0 from which we find that

$$\mathcal{R} |m, n\rangle = |-m, -n\rangle.$$

Therefore, in the calculation of the partition function only states with $|m = 0, n = 0\rangle$ will contribute and we are left with a computation similar to the one in Sect. 4.2.1. Taking into account the action (4.48) and following the same steps as on p. 121, we find that we can replace the result of the free boson as

$$q^{-\frac{1}{24}} \prod_n \frac{1}{1 - q^n} \quad \longrightarrow \quad q^{-\frac{1}{24}} \prod_n \frac{1}{1 - (-q^n)} = \sqrt{2} \sqrt{\frac{\eta(\tau)}{\vartheta_2(\tau)}},$$

where we employed the definition of ϑ_2 from p. 137. We thus express Eq. (4.47) in the following way:

$$\mathcal{Z}(\tau, \bar{\tau}) = \frac{1}{2} \mathcal{Z}_{\text{circ.}}(\tau, \bar{\tau}) + \left| \frac{\eta(\tau)}{\vartheta_2(\tau)} \right|. \quad (4.49)$$

Modular Invariance and Twisted Sectors

However, Eq. (4.49) cannot be the full partition function because the second term is not invariant under modular transformations. In particular, recalling our results from Sect. 4.2.4, we have

$$T \circ \left| \frac{\eta}{\vartheta_2} \right| \xleftrightarrow{S} \left| \frac{\eta}{\vartheta_4} \right| \xleftrightarrow{T} \left| \frac{\eta}{\vartheta_3} \right| \circ S,$$

so that a so-called twisted sector has to be added

$$\mathcal{Z}_{\text{tw}}(\tau, \bar{\tau}) = \left| \frac{\eta(\tau)}{\vartheta_4(\tau)} \right| + \left| \frac{\eta(\tau)}{\vartheta_3(\tau)} \right|. \quad (4.50)$$

In order to explain this terminology, let us note the following explicit form of $\sqrt{\eta/\vartheta_4}$:

$$\sqrt{\frac{\eta(\tau)}{\vartheta_4(\tau)}} = q^{\frac{1}{16} - \frac{1}{24}} \prod_{n=0}^{\infty} \frac{1}{1 - q^{n+\frac{1}{2}}}.$$

We can interpret this expression as the partition function in a sector with ground state energy $L_0|0\rangle = \frac{1}{16}|0\rangle$ and half-integer modes $j_{n+\frac{1}{2}}$ in a Laurent expansion, that is,

$$j(z) = i \partial X(z, \bar{z}) = \sum_{n \in \mathbb{Z}} j_{n+\frac{1}{2}} z^{-(n+\frac{1}{2})-1}.$$

Next, we observe that this mode expansion respects the symmetry

$$j(e^{2\pi i} z) = -j(z) = \mathcal{R} j(z) \mathcal{R},$$

and therefore the free boson $X(z, \bar{z})$ is invariant under rotations in the complex plane up to the action of the discrete symmetry \mathcal{R} . In general, if a field in a CFT is invariant only up to an action of the orbifold, it is said to be in a twisted sector. The partition function in the twisted sector can be defined as

$$\mathcal{Z}_{\text{tw}}(\tau, \bar{\tau}) = \text{Tr}_{\mathcal{H}_{\text{tw}}} \left(\frac{1 + \mathcal{R}}{2} q^{L_0 - \frac{c}{24}} \bar{q}^{\bar{L}_0 - \frac{c}{24}} \right) = \left| \frac{\eta(\tau)}{\vartheta_4(\tau)} \right| + \left| \frac{\eta(\tau)}{\vartheta_3(\tau)} \right|, \quad (4.51)$$

which also makes the meaning of the second term in Eq. (4.50) evident. Let us emphasise that modular invariance again forced us to introduce this new sector into the theory.

To summarise, the modular invariant partition function of the \mathbb{Z}_2 -orbifold of the free boson on the circle reads

$$\boxed{\mathcal{Z}_{\text{orb.}}(\tau, \bar{\tau}) = \frac{1}{2} \mathcal{Z}_{\text{circ.}}(\tau, \bar{\tau}) + \left| \frac{\eta(\tau)}{\vartheta_2(\tau)} \right| + \left| \frac{\eta(\tau)}{\vartheta_4(\tau)} \right| + \left| \frac{\eta(\tau)}{\vartheta_3(\tau)} \right|},$$

and we note that the states in the twisted sector have an overall two-fold degeneracy. This can be understood from the fact that the twisted sectors are localised at the fixed point of the orbifold action, which in our case are the two fixed points at the ends of the line segment shown in Fig. 4.4.

Remarks

- This example demonstrates the beautiful stringy relationship between the CFT on the world-sheet and the background geometry it is moving in. Just following the consistency condition for the two-dimensional CFT, we were able to extract geometric information about the background space the free boson took values in. Here we discussed an almost trivial example; however, more involved configurations can be understood along the same lines.

- In general, for an orbifold with abelian symmetry group G the partition function takes the form

$$\mathcal{Z}(\tau, \bar{\tau}) = \frac{1}{|G|} \sum_{g, h \in G} \text{Tr}_h \left(g q^{L_0 - \frac{c}{24}} \bar{q}^{\bar{L}_0 - \frac{c}{24}} \right), \quad (4.52)$$

where $|G|$ denotes the order of the group G and the trace is over all twisted sectors for which the fields $\phi_{\text{tw.}}(z, \bar{z})$ obey

$$\phi_{\text{tw.}}(e^{2\pi i} z, e^{-2\pi i} \bar{z}) = h \phi_{\text{tw.}}(z, \bar{z}) h^{-1}.$$

- Note that in the \mathbb{Z}_2 -orbifold partition function, only $\mathcal{Z}_{\text{circ.}}$ depends on the radius R of the circle. Therefore, the orbifold partition function is also invariant under T-duality, i.e. $\mathcal{Z}_{\text{orb.}}(R) = \mathcal{Z}_{\text{orb.}}(2/R)$. Moreover, one can show that $\mathcal{Z}_{\text{orb.}}(R = \sqrt{2}) = \mathcal{Z}_{\text{circ.}}(R = 2\sqrt{2})$, so that the moduli spaces of the circle and orbifold partition function intersect, that is, they agree in one point. In fact, the moduli space of conformal field theories with central charge $c = 1$ has been classified which shows an A-D-E-type structure. For more details we refer to the literature.

4.3 The Verlinde Formula

In this section, we are going to study an intricate relationship between the modular properties of a conformal field theory and its fusion rules. In particular, for Rational conformal field theories the behaviour of the theory under modular transformations is much easier to extract than the fusion rules. The latter are determined via the methods shown in Sect. 2.11 which can become quite involved. However, the so-called Verlinde formula allows to compute the fusion rule coefficients in terms of the modular S -matrix elements.

S-Matrix and Fusion Algebra

Let us consider a Rational conformal field theory (RCFT) with central charge c and a finite number of HWRs ϕ_i with characters χ_i where $i = 0, \dots, N - 1$. Then, as we have seen previously, there exists a representation of $SL(2, \mathbb{Z})/\mathbb{Z}_2$ on that space of characters, in particular, there is a matrix S_{ij} such that

$$\chi_i \left(-\frac{1}{\tau} \right) = \sum_{j=0}^{N-1} S_{ij} \chi_j(\tau). \quad (4.53)$$

As encountered in Sect. 4.2.2, for the Θ -functions generically $S^2 \neq \mathbb{1}$ but $S^2 = C$ with the charge conjugation matrix C satisfying $C^2 = \mathbb{1}$. Furthermore (in all known cases), the S -matrix is unitary and symmetric

$$SS^\dagger = S^\dagger S = \mathbb{1} , \quad S = S^T . \tag{4.54}$$

One of the deepest results in CFT is that there exists an intricate relation between the modular S -matrix (torus partition function) and the fusion algebra for the OPE on the sphere (tree-level). Namely, the fusion coefficients $N_{ij}^k \in \mathbb{Z}_0^+$ can be computed from the S -matrix via the Verlinde formula

$$N_{ij}^k = \sum_{m=0}^{N-1} \frac{S_{im} S_{jm} S_{mk}^*}{S_{0m}} , \tag{4.55}$$

where S^* denotes the complex conjugate of S and the subindex 0 labels the identity representation. It is quite remarkable that the above combination of $S_{ij} \in \mathbb{C}$ always gives non-negative integers.

Another way of stating the Verlinde formula is as follows. We have seen in Eq. (2.131) that the fusion matrices $(\bar{N}_i)_{jk} = N_{ij}^k$ commute among each other. Therefore, they can be diagonalised simultaneously, that is, there exists a matrix S such that

$$\bar{N}_i = S D_i S^{-1} ,$$

where D_i is a diagonal matrix. Using the unitarity and symmetry of the modular S -matrix, the Verlinde formula (4.55) states that $S = S$ with the entries of the diagonalised fusion matrices given by $(D_i)_{mm} = S_{im}/S_{0m}$.

Remark

Similar to Eq. (4.53), on the space of characters of an RCFT there exists also a matrix T_{ij} such that a modular T -transformation can be written as

$$\chi_i(\tau + 1) = \sum_{j=0}^{N-1} T_{ij} \chi_j(\tau) .$$

Without detailed derivation, we note furthermore that one can choose a basis such that the matrix T_{ij} takes the following form:

$$T_{ij} = \delta_{ij} e^{2\pi i(h_i - \frac{c}{24})} , \tag{4.56}$$

where h_i denotes the conformal weight of the highest weight representation corresponding to the character $\chi_i(\tau)$.

Fusion Rules for $\hat{\mathfrak{u}}(1)_k$

Before we present a rough sketch of the proof of the Verlinde formula, we will discuss the rational CFTs $\hat{\mathfrak{u}}(1)_k$ from Sect. 4.2.2 as a simple example. Recalling the corresponding modular S -matrix (4.30)

$$S_{pq} = \frac{1}{\sqrt{2k}} \exp\left(-\pi i \frac{pq}{k}\right), \quad p, q = -k + 1, \dots, k,$$

and using the Verlinde formula (4.55), we can write for the fusion coefficients

$$N_{ab}^c = \sum_{m=-k+1}^k \frac{1}{2k} e^{-\frac{\pi i}{k}(ma+mb-mc)} = \frac{1}{2k} \sum_{m=-k+1}^k e^{-\frac{2\pi im}{2k}(a+b-c)} = \delta^{(2k)}(a+b-c),$$

where we defined $\delta^{(N)}(x) = 1$ if $x = 0 \pmod N$ and zero otherwise. For the fusion algebra $[\phi_i] \times [\phi_j] = \sum_k N_{ij}^k [\phi_k]$, we then have

$$[\phi_m] \times [\phi_n] = [\phi_{m+n \bmod 2k}].$$

Finally, recalling that the partition function of $\widehat{\mathfrak{u}}(1)_1$ is the same as for $\widehat{\mathfrak{su}}(2)_1$, we have also found the fusion rules for the two highest weight representations of the $\widehat{\mathfrak{su}}(2)_1$ Kač–Moody algebra

$$[\phi_0] \times [\phi_0] = [\phi_0], \quad [\phi_0] \times [\phi_1] = [\phi_1], \quad [\phi_1] \times [\phi_1] = [\phi_0],$$

where the subscripts $l = 0, 1$ label the spin $\frac{l}{2}$ highest weight representation of $\widehat{\mathfrak{su}}(2)_1$.

Sketch of the Proof of the Verlinde Formula³

We do not intend to give a full proof of the Verlinde formula but only want to present the main idea. For further details we refer to the original literature.

The proof of the Verlinde formula includes monodromy transformations on the space of conformal blocks introduced in Sect. 2.12, which shows that indeed the modular S -transformation diagonalises the fusion rules. Moreover, the pentagon identity for the fusing matrices from Sect. 2.13 is at the heart of the proof.

- The characters χ_j can be viewed as the conformal blocks for the zero-point amplitude on the torus, which is identical to the one-point amplitude of the identity operator. Writing the identity as the result of the fusion of $\phi_i \times \phi_i^*$, where ϕ_i^* denotes the conjugate operator of ϕ_i , the character can also be written as a certain scaling limit of the conformal block of the two-point function $\langle \phi_i(z) \phi_i^*(z) \rangle_{\mathbb{T}^2}$ on the torus

³ This paragraph can be omitted in a first reading.

$$\chi_j = \lim_{z \rightarrow w} (z - w)^{2h_i} \mathcal{F}_j^{i,i^*}(z - w) .$$

- Next, one defines a monodromy operator $\Phi_i(\mathbf{C})$ acting on the characters in the following way:

$$\Phi_i(\mathbf{C}) \chi_j = \lim_{z \rightarrow w} (z - w)^{2h_i} M_{\phi_i, \mathbf{C}} \left(\mathcal{F}_j^{i,i^*}(z - w) \right) .$$

Here $M_{\phi_i, \mathbf{C}}$ is defined by taking ϕ_i , moving it around the one-cycle \mathbf{C} on the torus \mathbb{T}^2 and computing the effect of that monodromy on the conformal block. A basis of homological one-cycles is given by the fundamental cycles on \mathbb{T}^2 , denoted as \mathbf{A} and \mathbf{B} (see Fig. 4.5). Note that \mathbf{A} is the space-like cycle $0 \leq \text{Re } w \leq 2\pi$ and that \mathbf{B} is the time-like cycle in the τ direction. Moreover, we recall from Sect. 4.1 that the modular S -transformation exchanges \mathbf{A} and \mathbf{B} .

- Moving ϕ_i around the \mathbf{A} -cycle does not change the conformal family ϕ_j circulating along the time-like direction. Therefore, $\Phi_i(\mathbf{A})$ acts diagonally on the characters

$$\Phi_i(\mathbf{A}) \chi_j = \lambda_i^j \chi_j .$$

- The action $\Phi_i(\mathbf{B})$ is more involved as ϕ_i is moved around the one-cycle where ϕ_j is circulating. We thus do expect a non-trivial monodromy action. However, this action can be separated into essentially two transformations on the conformal blocks, and after employing the pentagon identity from Sect. 2.13, one arrives at the result that

$$\Phi_i(\mathbf{B}) \chi_j = N_{ij}^k \chi_k .$$

- Since the S -transformation exchanges the \mathbf{A} with the \mathbf{B} cycle, it also acts as $\Phi_i(\mathbf{B}) = S \Phi_i(\mathbf{A}) S^{-1}$, which means it diagonalises the fusion rules. We can therefore write

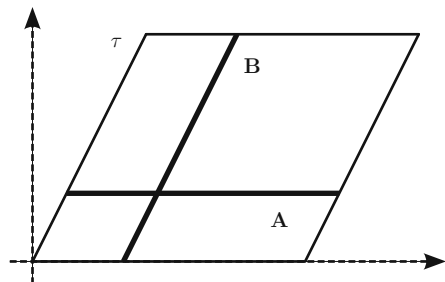

Fig. 4.5 Basis of homological one-cycles on the torus \mathbb{T}^2

$$N_{ij}^k = \sum_m S_{jm} \lambda_i^m \bar{S}_{mk}.$$

Choosing $j = 0$ and using $N_{i0}^k = \delta_{i,k}$, we can determine $\lambda_i^m = S_{im}/S_{0m}$ which eventually gives the Verlinde formula.

4.4 The $\widehat{\mathfrak{su}}(2)_k$ Partition Functions

In Sect. 3.3, we have considered unitary highest weight representations of conformal field theories with $\widehat{\mathfrak{su}}(2)_k$ symmetry which can only exist for $k \in \mathbb{Z}^+$ and $0 \leq l \leq k$ where l determines the $\mathfrak{su}(2)$ spin as $s = \frac{l}{2}$. In the present section, we will study the corresponding one-loop partition functions.

Character and S-Matrix for $\widehat{\mathfrak{su}}(2)_k$

In order to determine the partition function, let us consider the charged characters of $\widehat{\mathfrak{su}}(2)_k$ whose general form we defined in Eq. (4.38). These characters contain not only the degeneracies for a particular conformal weight, but also the information about the \hat{j}_0^3 charge. Without derivation, we note that the $\widehat{\mathfrak{su}}(2)_k$ characters can be determined from the so-called Weyl–Kač character formula to be of the following form:

$$\chi_l^{(k)}(\tau, z) = \frac{\Theta_{l+1,k+2}(\tau, z) - \Theta_{-l-1,k+2}(\tau, z)}{\Theta_{1,2}(\tau, z) - \Theta_{-1,2}(\tau, z)}, \tag{4.57}$$

with $0 \leq l \leq k$. This expression involves the generalised Θ -functions

$$\Theta_{l,k}(\tau, z) = \sum_{n \in \mathbb{Z} + \frac{l}{2k}} q^{kn^2} e^{-2\pi inkz}, \tag{4.58}$$

which for $z = 0$ reduce to the usual Θ -functions introduced in Eq. (4.24).

Note that in Eq. (4.57), the differences in the numerator and denominator vanish for $z \rightarrow 0$. However, to derive the modular properties of $\chi_l^{(k)}(\tau, z)$ this form is very appropriate. In particular, for the modular S -transformation of $\chi_l^{(k)}(\tau, z)$, we can use the results for $\Theta_{l,k}(\tau, z = 0)$ from Sect. 4.2.2. Let us calculate

$$\begin{aligned}
& \Theta_{l+1,k+2}\left(-\frac{1}{\tau}, 0\right) - \Theta_{-l-1,k+2}\left(-\frac{1}{\tau}, 0\right) \\
&= \sqrt{-i\tau} \sum_{l'=-k-1}^{k+2} (S_{l+1,l'} - S_{-l-1,l'}) \Theta_{l',k+2}(\tau) \\
&= \sqrt{-i\tau} \left(\sum_{l'=0}^k (S_{l+1,-l'-1} - S_{-l-1,-l'-1}) \Theta_{-l'-1,k+2}(\tau) \right. \\
&\quad + (S_{l+1,0} - S_{-l-1,0}) \Theta_{0,k+2}(\tau) \\
&\quad + \sum_{l'=0}^k (S_{l+1,l'+1} - S_{-l-1,l'+1}) \Theta_{l'+1,k+2}(\tau) \\
&\quad \left. + (S_{l+1,k+2} - S_{-l-1,k+2}) \Theta_{k+2,k+2}(\tau) \right),
\end{aligned}$$

where from the second to the last line we performed a particular rewriting of the sum. Next, we recall from Eq. (4.30) the S -matrix of the Θ -functions which in the present case reads

$$S_{l,l'} = \frac{1}{\sqrt{2(k+2)}} \exp\left(-\pi i \frac{ll'}{k+2}\right).$$

Using Eq. (4.29), we see that in the calculation above the terms involving $\Theta_{0,k+2}(\tau)$ and $\Theta_{k+2,k+2}(\tau)$ vanish while the other terms can be simplified to

$$\begin{aligned}
& \Theta_{l+1,k+2}\left(-\frac{1}{\tau}, 0\right) - \Theta_{-l-1,k+2}\left(-\frac{1}{\tau}, 0\right) \\
&= \frac{-2i\sqrt{-i\tau}}{\sqrt{2(k+2)}} \sum_{l'=0}^k \sin\left(\frac{\pi}{k+2} (l+1)(l'+1)\right) \left(\Theta_{l'+1,k+2}(\tau, 0) - \Theta_{-l'-1,k+2}(\tau, 0)\right).
\end{aligned}$$

For the denominator in Eq. (4.57), we use this expression with $k = 0$ and $l = 0$ to find

$$\Theta_{1,2}\left(-\frac{1}{\tau}, 0\right) - \Theta_{-1,2}\left(-\frac{1}{\tau}, 0\right) = \frac{-2i\sqrt{-i\tau}}{2} \sin\left(\frac{\pi}{2}\right) \left(\Theta_{1,2}(\tau, 0) - \Theta_{-1,2}(\tau, 0)\right),$$

from which we infer the modular S -matrix for the character (4.57) as

$$\boxed{S_{l,l'}^{(k)} = \sqrt{\frac{2}{k+2}} \sin\left(\frac{\pi}{k+2} (l+1)(l'+1)\right) \quad \text{with } l, l' = 0, \dots, k.} \quad (4.59)$$

Fusion Coefficients for $\widehat{\mathfrak{su}}(2)_k$

Having determined the explicit form of the S -matrix, we can now apply the Verlinde formula (4.55) to compute the fusion coefficients of $\widehat{\mathfrak{su}}(2)_k$ appearing in the algebra

$$[\phi_{l_1}] \times [\phi_{l_2}] = \sum_{l_3=0}^k N_{l_1 l_2}^{l_3} [\phi_{l_3}] .$$

We expect the fusion coefficients to be consistent with the tensor product of spins $(\frac{l_1}{2}, \frac{l_2}{2})$, and indeed, one finds

$$N_{l_1 l_2}^{l_3} = \begin{cases} 1 & \text{if } |l_1 - l_2| \leq l_3 \leq \min(l_1 + l_2, 2k - l_1 - l_2) \\ & \text{and } l_1 + l_2 + l_3 = 0 \pmod 2 , \\ 0 & \text{otherwise .} \end{cases} \tag{4.60}$$

Partition Functions

Out of the characters (4.57), we can now construct modular invariant partition functions. As we have already indicated around Eq. (4.32), this amounts to determining all matrices $M_{l'}$ such that

$$\mathcal{Z}^{(k)}(\tau, \bar{\tau}) = \sum_{l, l'} \chi_l^{(k)}(\tau) M_{l' l}^{(k)} \bar{\chi}_{l'}^{(k)}(\bar{\tau}) \tag{4.61}$$

is modular invariant, that is, $S^{(k)T} M^{(k)} S^{(k)*} = M^{(k)}$. Since the entries $M_{l' l}^{(k)}$ have the interpretation as the number of degeneracies of states in the Hilbert space, they must be non-negative integers. In addition, for the vacuum to only appear once, we have to require $M_{00}^{(k)} = 1$. Since in the present case $S^{(k)}$ shown in Eq. (4.59) is symmetric and real, we find the condition $S^{(k)} M^{(k)} S^{(k)} = M^{(k)}$ which can be written as

$$[M^{(k)}, S^{(k)}] = 0 .$$

Furthermore, it turns out that in order for Eq. (4.61) to be invariant under T -transformations, one has to satisfy the level-matching condition $h_l - \bar{h}_{l'} \in \mathbb{Z}$.

Clearly, the identity matrix $M = \mathbb{1}$ gives rise to a modular invariant partition function, but Cappelli, Itzykson and Zuber found the complete classification of *all* matrices M with the properties above. The corresponding partition functions are listed in Table 4.1 which is known as the A-D-E classification. Note that the subscripts of the characters label again the highest weight representation. Furthermore, the name of each class corresponds to a Lie group to which the partition function can be associated, and the dual Coxeter number of each algebra is $k + 2$.

Table 4.1 All $\widehat{\mathfrak{su}}(2)_k$ modular invariant partition functions. For ease of notation, the (k) -labels on the characters and partition functions have been omitted

Level	Partition function	Name
$k = n$	$\mathcal{Z} = \sum_{l=0}^n \chi_l ^2$	$A_{n+1}, n \geq 1$
$k = 4n$	$\mathcal{Z} = \sum_{l=0}^{n-1} \chi_{2l} + \chi_{k-2l} ^2 + 2 \chi_{\frac{k}{2}} ^2$	$D_{2n+2}, n \geq 1$
$k = 4n - 2$	$\mathcal{Z} = \sum_{l=0}^{\frac{k}{2}} \chi_{2l} ^2 + \sum_{l=0}^{2n-2} \chi_{2l+1} \bar{\chi}_{k-2l-1}$	$D_{2n+1}, n \geq 2$
$k = 10$	$\mathcal{Z} = \chi_0 + \chi_6 ^2 + \chi_3 + \chi_7 ^2 + \chi_4 + \chi_{10} ^2$	E_6
$k = 16$	$\mathcal{Z} = \chi_0 + \chi_{16} ^2 + \chi_4 + \chi_{12} ^2 + \chi_6 + \chi_{10} ^2 + (\chi_2 + \chi_{14}) \bar{\chi}_8 + \chi_8 (\bar{\chi}_2 + \bar{\chi}_{14}) + \chi_8 ^2$	E_7
$k = 28$	$\mathcal{Z} = \chi_0 + \chi_{10} + \chi_{18} + \chi_{28} ^2 + \chi_6 + \chi_{12} + \chi_{16} + \chi_{22} ^2$	E_8

Remarks

- Note that only for $\widehat{\mathfrak{su}}(3)_k$ a similar classification has been achieved. There one finds the A_{n+1} and D_n series and, in addition, five exceptional invariants at levels $k = 5_1, 5_2, 9_1, 9_2, 21$.
- Note also that the A-D-E classification of $\widehat{\mathfrak{su}}(2)_k$ invariants is via string theory compactifications related to the A-D-E classifications of singularities. The latter are via Type IIA–heterotic string duality related to the A-D-E classification of simple Lie algebras.

4.5 Modular Invariants of $\text{Vir}_{c < 1}$

In this section, we will construct modular invariant partition functions for the unitary models of the Virasoro algebra with central charges $c < 1$.

Branching Functions and S-Matrix

We start by recalling from p. 105 that the GKO coset $(\widehat{\mathfrak{su}}(2)_k \times \widehat{\mathfrak{su}}(2)_1) / \widehat{\mathfrak{su}}(2)_{k+1}$ allows to determine the following decomposition of $\widehat{\mathfrak{su}}(2)_k \times \widehat{\mathfrak{su}}(2)_1$ HWRs into highest weight representations of $\widehat{\mathfrak{su}}(2)_{k+1}$ and Vir_c :

$$(p-1)_k \otimes (\epsilon)_1 = \bigoplus_{\substack{0 \leq (q-1) \leq k+1 \\ p-q+\epsilon \equiv 0 \pmod{2}}} (q-1)_{k+1} \otimes (h_{p,q}(m)), \quad (4.62)$$

where $\epsilon = 0, 1$, $m = k + 2$ and $0 \leq (p-1) \leq k$. Next, we deduce the characters which are given by a trace over the corresponding Hilbert space. Noting the relation $\text{Tr}_{A \otimes B}(\dots) = \text{Tr}_A(\dots) \cdot \text{Tr}_B(\dots)$, that is, the trace over $A \otimes B$ is equal to the trace over A times the trace over B , we find

$$\chi_{(p-1)}^{(k)}(\tau) \chi_{(\epsilon)}^{(1)}(\tau) = \sum_{\substack{0 \leq (q-1) \leq k+1 \\ p-q+\epsilon \equiv 0 \pmod{2}}} \chi_{(q-1)}^{(k+1)}(\tau) \chi_{(p,q)}^{\text{Vir}}(\tau), \quad (4.63)$$

where $\chi_{(p,q)}^{\text{Vir}}(\tau)$ are the so-called branching functions we are interested in.

Let us now apply a modular S -transformation to both sides of Eq. (4.63) in order to extract the modular S -transformation of the branching function $\chi_{(p,q)}^{\text{Vir}}(\tau)$. We then find

$$S_{p-1, p'-1}^{(k)} S_{\epsilon, \epsilon'}^{(1)} = S_{q-1, q'-1}^{(k+1)} S_{(p,q), (p', q')}^{\text{Vir}},$$

with the restrictions $p - q + \epsilon = 0 \pmod{2}$ as well as $p, p' = 1, \dots, k + 1$, $q, q' = 1, \dots, k + 2$ and $\epsilon, \epsilon' = 0, 1$. Since the S -matrix for $\widehat{\mathfrak{su}}(2)_k$ is real and symmetric, using Eq. (4.54) we find $(S^{(k)})^{-1} = S^{(k)}$. Utilising the explicit form of $S^{(k)}$ from Eq. (4.59), we then obtain

$$S_{(p,q), (p', q')}^{\text{Vir}} = S_{p-1, p'-1}^{(k)} S_{\epsilon, \epsilon'}^{(1)} S_{q-1, q'-1}^{(k+1)} \quad (4.64)$$

$$S_{(p,q), (p', q')}^{\text{Vir}} = \sqrt{\frac{2}{(k+2)(k+3)}} (-1)^{(p-q)(p'-q')} \sin\left(\frac{\pi}{k+2} p p'\right) \sin\left(\frac{\pi}{k+3} q q'\right).$$

Let us remark that equating the Verlinde formula (4.55) for the present case gives precisely the fusion coefficients from Sect. 2.11 with all non-vanishing coefficients taking values $N_{ij}^k = 1$.

Modular Invariant Partition Functions

As we can see from Eq. (4.64), the S -matrix for the branching functions is essentially the product of an $\widehat{\mathfrak{su}}(2)_k$ and an $\widehat{\mathfrak{su}}(2)_{k+1}$ S -matrix. Therefore, the classification of modular invariant partition functions boils down to combining modular invariants of $\widehat{\mathfrak{su}}(2)_k$ and $\widehat{\mathfrak{su}}(2)_{k+1}$. Looking at Table 4.1, we see that the D and E invariants all have even level k . But since one of the $\widehat{\mathfrak{su}}(2)_k$ factors in Eq. (4.62) has necessarily odd level, the partition function has to involve precisely one odd A invariant. The only possible combinations are therefore (AA) , (AD) , (DA) , (AE) and (EA) .

In order to illustrate the construction, let us now quickly state some examples for modular invariant partition functions of unitary models without a precise derivation. One finds for instance

$$\begin{aligned}
\mathcal{Z}_{A_{k+1}, A_{k+2}} &= \frac{1}{2} \sum_{p=1}^{k+1} \sum_{q=1}^{k+2} |\chi_{p,q}|^2, \\
\mathcal{Z}_{D_{\frac{k}{2}+2}, A_{k+2}} &= \frac{1}{2} \sum_{q=1}^{k+2} \left(\sum_{p=0}^{\frac{k-4}{4}} |\chi_{2p+1,q} + \chi_{k-2p+1,q}|^2 + 2|\chi_{\frac{k}{2}+1,q}|^2 \right)_{k=4n}, \\
\mathcal{Z}_{A_{k+1}, D_{\frac{k+1}{2}+2}} &= \frac{1}{2} \sum_{p=1}^{k+1} \left(\sum_{q=0}^{\frac{k-3}{4}} |\chi_{p,2q+1} + \chi_{p,k-2q+2}|^2 + 2|\chi_{p, \frac{k+1}{2}+1}|^2 \right)_{k=4n-1}, \\
\mathcal{Z}_{E_6, A_{12}} &= \frac{1}{2} \sum_{q=1}^{12} \left(|\chi_{1,q} + \chi_{7,q}|^2 + |\chi_{4,q} + \chi_{8,q}|^2 + |\chi_{5,q} + \chi_{11,q}|^2 \right).
\end{aligned}$$

Example with \mathcal{W} Symmetry

Let us now take a closer look at the three-state Potts model. This is a unitary minimal model of the Virasoro algebra with central charge $c = \frac{4}{5}$ which, using Eq. (3.29), implies that $k = 3$. In this case, we see from above that besides the diagonal \mathcal{Z}_{A_4, A_5} modular invariant partition function, there is also \mathcal{Z}_{A_4, D_4} with the following explicit form:

$$\begin{aligned}
\mathcal{Z}_{A_4, D_4} &= \frac{1}{2} \sum_{p=1}^4 \sum_{q=0}^0 \left(|\chi_{p,2q+1} + \chi_{p,5-2q}|^2 + 2|\chi_{p,3}|^2 \right) \\
&= \frac{1}{2} \left(|\chi_{1,1} + \chi_{1,5}|^2 + 2|\chi_{1,3}|^2 + |\chi_{2,1} + \chi_{2,5}|^2 + 2|\chi_{2,3}|^2 \right. \\
&\quad \left. + |\chi_{3,1} + \chi_{3,5}|^2 + 2|\chi_{3,3}|^2 + |\chi_{4,1} + \chi_{4,5}|^2 + 2|\chi_{4,3}|^2 \right) \\
&= |\chi_{1,1} + \chi_{1,5}|^2 + |\chi_{2,1} + \chi_{2,5}|^2 + 2|\chi_{1,3}|^2 + 2|\chi_{2,3}|^2.
\end{aligned}$$

The conformal weights of the primary fields in the characters of the first term are computed using Eq. (2.119) with $m = 5$ as

$$h_{1,1} = \frac{(6 \cdot 1 - 5 \cdot 1)^2 - 1}{4 \cdot 5 \cdot 6} = 0, \quad h_{1,5} = \frac{(6 \cdot 1 - 5 \cdot 5)^2 - 1}{4 \cdot 5 \cdot 6} = 3.$$

Therefore, $\chi_{1,1}$ corresponds to the vacuum representation $\phi_{1,1}$ and the character $\chi_{1,5}$ is built upon a primary field $\phi_{1,5}$ of conformal dimension $h = 3$. Since the primary $\phi_{1,5}$ appears together with the vacuum, it has to be a chiral primary. Thus, besides the Virasoro generator, there exists a further generator of the chiral symmetry algebra and, following our discussion from Sect. 3.7, this symmetry algebra should be a $\mathcal{W}(2, 3)$ algebra with central charge $c = \frac{4}{5}$. With respect to the $\mathcal{W}(2, 3)$ algebra, that is, using L_m as well as W_m modes to construct states, the partition function \mathcal{Z}_{A_4, D_4} is then expected to be the diagonal partition function

$$\mathcal{Z}_{\mathcal{W}(2,3)} = |\bar{\chi}_0|^2 + |\bar{\chi}_{\frac{2}{5}}|^2 + 2|\bar{\chi}_{\frac{2}{3}}|^2 + 2|\bar{\chi}_{\frac{1}{15}}|^2.$$

In fact, the additional chiral fields in the general $\mathcal{Z}_{A_{k+1}, D_{(k+1)/2+2}}$ partition function have conformal weights $h_{1,k+2} = n(4n-1)$ with $k = 4n-1$, so that an off-diagonal partition function with respect to the Virasoro algebra can be interpreted as a diagonal partition function with respect to an $\mathcal{W}(2, n(4n-1))$ algebra.

4.6 The Parafermions

In this section, we will study in more detail the parafermionic models already encountered in Sect. 3.6. These theories are given by the coset construction

$$\frac{\widehat{\mathfrak{su}}(2)_k}{\widehat{\mathfrak{u}}(1)_k} \quad \text{with} \quad c = \frac{2(k-1)}{k+2}, \quad (4.65)$$

where for the calculation of the central charge, we refer to Eq. (3.27). Note also that for $k=2$, we have $c = \frac{1}{2}$ which is the Ising model, for $k=3$ we get $c = \frac{4}{5}$ being the three-state Potts model, and for $k=4$ we find $c=1$.

Characters for Parafermionic Theories

Analogous to the previous section, the characters for the parafermionic theories can be determined from the branching rules of highest weight representations given in Eq. (3.30). In particular, from the decomposition of HWRs

$$(\lambda_{\widehat{\mathfrak{su}}(2)_k}) = \bigoplus_{\lambda_{\widehat{\mathfrak{u}}(1)_k}} (\lambda_{\widehat{\mathfrak{u}}(1)_k}) \otimes (\lambda_{\widehat{\mathfrak{su}}(2)_k/\widehat{\mathfrak{u}}(1)_k}),$$

we find the following decomposition of $\widehat{\mathfrak{su}}(2)_k$ characters into $\widehat{\mathfrak{u}}(1)_k$ characters studied in Sect. 4.2.3 and branching functions $\widetilde{C}_{l,m}^{(k)}(\tau)$:

$$\chi_l^{(k)}(\tau) = \sum_{m=-k+1}^k \frac{\Theta_{m,k}(\tau)}{\eta(\tau)} \widetilde{C}_{l,m}^{(k)}(\tau), \quad l = 0, \dots, k. \quad (4.66)$$

From Sect. 4.2.3, we also know that in the case $k=1$ the characters of $\widehat{\mathfrak{su}}(2)_1$ are equal to the characters of $\widehat{\mathfrak{u}}(1)_1$

$$\chi_0^{(1)}(\tau) = \frac{\Theta_{0,1}(\tau)}{\eta(\tau)}, \quad \chi_1^{(1)}(\tau) = \frac{\Theta_{1,1}(\tau)}{\eta(\tau)}.$$

Comparing with Eq. (4.66), we then see that for the branching functions $\widetilde{C}_{l,m}^{(1)}(\tau)$, we have

$$\tilde{C}_{0,0}^{(1)} = 1, \quad \tilde{C}_{0,1}^{(1)} = 0, \quad \tilde{C}_{1,0}^{(1)} = 0, \quad \tilde{C}_{1,1}^{(1)} = 1.$$

These relations for the case $k = 1$ suggest a more general selection rule for the sum in Eq. (4.66). And indeed, in the spirit of our analysis in Sect. 3.3, let us decompose an irreducible spin $\frac{1}{2}$ representation of $\mathfrak{su}(2)$ into its individual components in the following way:

$$\begin{aligned} (l)_{\mathfrak{su}(2)} &= (l)_{\mathfrak{u}(1)} \oplus (l-2)_{\mathfrak{u}(1)} \oplus \cdots \oplus (-l+2)_{\mathfrak{u}(1)} \oplus (-l)_{\mathfrak{u}(1)} \\ &= \bigoplus_{\substack{m=-l \\ m+l=0 \pmod{2}}}^l (m)_{\mathfrak{u}(1)}. \end{aligned} \quad (4.67)$$

The individual components are by itself representations of $\mathfrak{u}(1)$ factors which explains the subscript in the formula above. Also, we observe that the branching functions $\tilde{C}_{l,m}^{(k)}(\tau)$ should not carry any $\mathfrak{u}(1)$ charge since they correspond to the coset (4.65) in which, roughly speaking, the $\mathfrak{u}(1)$ part has been divided out. Therefore, including the branching rule of Eq. (4.67) in Eq. (4.66), we arrive at

$$\chi_l^{(k)}(\tau) = \sum_{\substack{m=-k+1 \\ l+m=0 \pmod{2}}}^k \frac{\Theta_{m,k}(\tau)}{\eta(\tau)} \tilde{C}_{l,m}^{(k)}(\tau). \quad (4.68)$$

The coefficients $C_{l,m}^{(k)}(\tau) = \tilde{C}_{l,m}^{(k)}(\tau)/\eta(\tau)$ are called the string functions of $\widehat{\mathfrak{su}}(2)_k$, whereas $\tilde{C}_{l,m}^{(k)}(\tau)$ with $l+m=0 \pmod{2}$ are the characters of the parafermions $\widehat{\mathfrak{su}}(2)_k/\widehat{\mathfrak{u}}(1)_k$.

Note finally that from the decomposition (4.68) we can read off the conformal weights of the branching functions $\tilde{C}_{l,m}^{(k)}(\tau)$ as

$$h_{(l,m)} = \frac{l(l+2)}{4(k+2)} - \frac{m^2}{4k}, \quad \begin{aligned} l &= 0, \dots, k, \\ m &= -k+1, \dots, k, \end{aligned}$$

where we employed Eqs. (3.11) and (4.34).

Modular Transformation of the Parafermionic Representations

Let us now determine the modular S -transformation of the parafermionic representations $\tilde{C}_{l,m}^{(k)}(\tau)$. Similar to the previous section, we are going to infer them from the modular properties of the $\widehat{\mathfrak{su}}(2)_k$ and $\widehat{\mathfrak{u}}(1)_k$ characters. In particular, performing an S -transformation on Eq. (4.68), we find

$$S_{l,l'}^{(k)} = S_{m,m'} \tilde{S}_{(l,m),(l',m')}^{(k)},$$

where $S^{(k)}$ is the S -matrix (4.59) and $S_{m,m'}$ denotes the S -matrix corresponding to $\Theta_{m,k}$. Using their explicit expressions and noting that $S^{-1} = S^*$, we obtain for the S -matrix of the parafermionic representations $\widetilde{C}_{l,m}^{(k)}(\tau)$ that

$$\begin{aligned} \widetilde{S}_{(l,m),(l',m')}^{(k)} &= S_{m,m'}^* S_{l,l'}^{(k)} \\ \widetilde{S}_{(l,m),(l',m')}^{(k)} &= \sqrt{\frac{1}{k(k+2)}} \sin\left(\frac{\pi}{k+2} (l+1)(l'+1)\right) e^{\pi i \frac{mm'}{k}}, \end{aligned} \quad (4.69)$$

where $l, l' = 0, \dots, k$ and $m, m' = -k+1, \dots, k$.

Remarks

- Let us note that we can write the $\widehat{\mathfrak{su}}(2)_k$ Kač–Moody algebra in the following way:

$$\widehat{\mathfrak{su}}(2)_k = \frac{\widehat{\mathfrak{su}}(2)_k}{\widehat{\mathfrak{u}}(1)_k} \times \widehat{\mathfrak{u}}(1)_k.$$

We can therefore express the $\widehat{\mathfrak{su}}(2)$ currents as a combination of a so-called parafermion $\psi_{\text{par}}(z)$ and a free boson $X(z, \bar{z})$ on a circle of radius $R = \sqrt{2k}$

$$\begin{aligned} j^+(z) &= \sqrt{k} \psi_{\text{par}}(z) e^{+i\sqrt{\frac{2}{k}} X(z)}, \\ j^-(z) &= \sqrt{k} \psi_{\text{par}}^\dagger(z) e^{-i\sqrt{\frac{2}{k}} X(z)}, \\ j^3(z) &= i\sqrt{2k} \partial_z X(z). \end{aligned}$$

For these currents to have conformal weight $h = 1$, the parafermionic fields have to have conformal dimension $h_{\text{par}} = 1 - \frac{1}{k} = \frac{k-1}{k}$, since the dimension of the vertex operator of the free boson is $h = \frac{\alpha^2}{2} = \frac{1}{k}$. This explains also the name *parafermion* since ψ_{par} is neither a boson nor a fermion.

- The parafermions feature a so-called level rank duality given by the relation

$$\frac{\widehat{\mathfrak{su}}(2)_k}{\widehat{\mathfrak{u}}(1)_k} = \frac{\widehat{\mathfrak{su}}(k)_1 \times \widehat{\mathfrak{su}}(k)_1}{\widehat{\mathfrak{su}}(k)_2}.$$

The unitary models of the parafermions are thus equivalent to the first unitary models of the GKO $\widehat{\mathfrak{su}}(k)$ coset. This could lead one to the conclusion that the \mathcal{W} algebra with $k \rightarrow \infty$ of $\widehat{\mathfrak{su}}(2)/\widehat{\mathfrak{u}}(1)$ has infinitely many generators of conformal dimension $\mathcal{W}(2, 3, 4, 5, 6, \dots)$. However, this is not the case as for the first unitary models of \mathcal{W}_{A_k} , the \mathcal{W} algebra truncates to a $\mathcal{W}(2, 3, 4, 5)$ algebra, which is different from the $\mathfrak{su}(5)$ Casimir algebra.

Table 4.2 Summary of partition functions, characters and S -matrices studied in this chapter

CFT	Partition function	Characters and S -Matrix
Boson	$Z_{\text{bos.}}(\tau, \bar{\tau}) = \frac{1}{\sqrt{2\tau_2}} \frac{1}{ \eta(\tau) ^2}$	
Boson on circle	$Z_{\text{circ.}}(\tau, \bar{\tau}) = \frac{1}{ \eta(\tau) ^2} \sum_{m,n} q^{\frac{1}{2}(\frac{m}{R} + \frac{n\theta}{2})^2} \bar{q}^{\frac{1}{2}(\frac{m}{R} - \frac{n\theta}{2})^2}$	
Boson on circle with $R = \sqrt{2k}$	$Z_{\widehat{\mathfrak{u}}(1)_k}(\tau, \bar{\tau}) = \sum_{m=-k+1}^k X_m^{(k)} ^2$	$X_m^{(k)} = \frac{\Theta_{m,k}(\tau)}{\eta(\tau)}$ $S_{m,m'} = \frac{1}{\sqrt{2k}} \exp(-\pi i \frac{m m'}{k})$
Boson \mathbb{Z}_2 -orbifold	$Z_{\text{orb.}}(\tau, \bar{\tau}) = \frac{Z_{\text{circ.}}(\tau, \bar{\tau})}{2} + \left \frac{\eta(\tau)}{\vartheta_2(\tau)} \right + \left \frac{\eta(\tau)}{\vartheta_4(\tau)} \right + \left \frac{\eta(\tau)}{\vartheta_3(\tau)} \right $	
Fermion	$Z_{\text{ferm.}}(\tau, \bar{\tau}) = \frac{1}{2} \left(\left \frac{\vartheta_3}{\eta} \right + \left \frac{\vartheta_4}{\eta} \right + \left \frac{\vartheta_2}{\eta} \right \right)$ $= \chi_0 \bar{\chi}_0 + \chi_{\frac{1}{2}} \bar{\chi}_{\frac{1}{2}} + \chi_{\frac{1}{16}} \bar{\chi}_{\frac{1}{16}}$	χ : Eq. (4.45)
$\widehat{\mathfrak{su}}(2)_k$	$Z^{(k)}(\tau, \bar{\tau}) = \sum_{l,l'} X_l^{(k)}(\tau) M_{l,l'}^{(k)} \bar{X}_{l'}(\bar{\tau})$	$\chi_l^{(k)}(\tau, z) = \frac{\Theta_{l,+1,k+2}(\tau, z) - \Theta_{l,-1,k+2}(\tau, z)}{\Theta_{1,2}(\tau, z) - \Theta_{-1,2}(\tau, z)}$ $S_{l,l'}^{(k)} = \sqrt{\frac{2}{k+2}} \sin\left(\frac{\pi}{k+2} (l+1)(l'+1)\right)$
Unitary models of $\text{Vir}_{c < 1}$	The combinations (AA), (AD), (DA), (AE), (EA) of $(\widehat{\mathfrak{su}}(2)_k, \widehat{\mathfrak{su}}(2)_{k+1})$ invariants	$\chi_{(p,q)}^{\text{Vir}}(\tau)$ S : Eq. (4.64)
Parafermions		$\tilde{\mathcal{C}}_{l,m}^{(k)}(\tau)$ where $l+m \equiv 0 \pmod{2}$ S : Eq. (4.69)

For explicit expressions see Table 4.1

4.7 Simple Currents

In the previous sections, we have presented various techniques to obtain modular invariant partition functions. In particular, for $\widehat{\mathfrak{su}}(2)_k$ we have shown a classification of matrices M in $\mathcal{Z} = \chi M \bar{\chi}$ leading to modular invariants. But, although we did not show the corresponding analysis, such a procedure is quite challenging. It would thus be helpful to have a method which allows to generate modular invariant partition functions without explicitly classifying all matrices M satisfying $S^T M S^* = M$.

The D_{2n+2} Partition Function

To motivate how such a method might work, let us recall the D_{2n+2} modular invariant partition function (MIPF) from Table 4.1 for $\widehat{\mathfrak{su}}(2)_{4n}$ conformal field theories with $k = 4n$ and $n \in \mathbb{Z}$

$$\mathcal{Z} = \sum_{l=0}^{n-1} \left| \chi_{2l} + \chi_{k-2l} \right|^2 + 2 \left| \chi_{\frac{k}{2}} \right|^2. \quad (4.70)$$

The conformal weights of the characters χ_l can be found in Eq. (3.11) which we recall for convenience here

$$h_l = \frac{l(l+2)}{4(k+2)}. \quad (4.71)$$

Using this expression for the combination of characters in $(\chi_{2l} + \chi_{k-2l})$, we find

$$h_{2l} - h_{k-2l} = \frac{2l(2l+2)}{4(k+2)} - \frac{(k-2l)(k-2l+2)}{4(k+2)} = l - \frac{k}{4} = l - n \in \mathbb{Z},$$

where we utilised that $k = 4n$. Note in particular that the vacuum character χ_0 is combined with χ_k which has conformal dimension $h_k = n \in \mathbb{Z}$. Therefore, the symmetry algebra is extended by a primary field of dimension $h = n$. Next, if we would allow for characters χ_l in Eq. (4.70) with generic $l \in \mathbb{Z}$, we would obtain

$$h_l - h_{k-l} = \frac{l}{2} - n \in \frac{\mathbb{Z}}{2},$$

which is non-integer for l odd. Since in Eq. (4.70) only even l appear, we conclude that the D_{2n+2} modular invariant partition function contains only characters which are combined in such a way that the difference of conformal dimensions is an integer.

Generalisation

To formalise these findings, let us define the field $J(z)$ as $J(z) = \phi_k(z)$ where $\phi_k(z)$ is a primary field of conformal dimension $h_k = n \in \mathbb{Z}$. Using the fusion coefficients from Eq. (4.60), we obtain

$$[J] \times [J] = [\mathbb{1}] , \quad [J] \times [\phi_l] = [\phi_{k-l}] , \quad [J] \times [\phi_{\frac{k}{2}}] = [\phi_{\frac{k}{2}}] .$$

Therefore, J organises the conformal families in orbits of length one and two, that is, there are orbits under the action of J with one or two elements. Moreover, we observe that in the partition function (4.70) the characters belonging to the same orbit appear together. Let us now define the so-called monodromy charge of ϕ_l in the following way:

$$Q(\phi_l) = h(J) + h(\phi_l) - h(J \phi_l) \pmod{1} . \tag{4.72}$$

For our example D_{2n+2} from above, we see that $Q(\phi_l) = \frac{l}{2}$ and that only combinations $(\chi_l + \chi_{k-l})$ with integer monodromy charge $Q(\phi_l)$ appear in the modular invariant partition function (4.70).

This observation can be generalised which leads to the concept of so-called simple currents. The definition of a simple current reads as follows:

Definition 2. *Given a Rational conformal field theory with highest weight representations ϕ_i , corresponding conformal families $[\phi_i]$ and fusion algebra*

$$[\phi_i] \times [\phi_j] = \sum_k N_{ij}^k [\phi_k] ,$$

a HWR J is called a simple current if its fusion with any other highest weight takes the simple form

$$[J] \times [\phi_i] = [\phi_{J(i)}] ,$$

which implies for the fusion coefficients that $N_{ji}^k = \delta_{k, J(i)}$. Here, the notation $J(i)$ means that J permutes the indices of the fields ϕ_i ⁴.

However, as we have seen in the previous example, the action of J can have fixed points. Note also that the ‘‘simple’’ action of J is the reason for the terminology simple current which has, however, no relation to fields with conformal dimension $h = 1$.

⁴ An example for such a permutation would be $(\phi_{J(1)}, \phi_{J(2)}, \phi_{J(3)}) = (\phi_2, \phi_1, \phi_3)$.

Simple Currents for RCFTs

In the following, we will now generalise the discussion from the previous paragraph to Rational conformal field theories with simple currents satisfying

$$h(J) \in \mathbb{Z} .$$

We observe that for J , there always exists a conjugate field J^* such that $[J] \times [J^*] = [\mathbb{1}]$. This immediately implies $[J] \times [J] = [J]$ is not possible because multiplying J^* from the right would lead to a contradiction. Therefore, either $[J] \times [J] = [\mathbb{1}]$ or there exists another field J^2 such that $[J] \times [J] = [J^2]$. By associativity, the latter is again a simple current. Finally, because we are considering RCFTs having only a finite number of HWRs, there must exist a length $L \in \mathbb{Z}$ such that

$$[J]^L = [\mathbb{1}] .$$

We can carry out similar arguments for a field ϕ_i leading to the conclusion that there has to be an integer l_i such that $[J]^{l_i} \times [\phi_i] = [\phi_i]$. Therefore, J organises all highest weight representations into so-called orbits of length $l_i = L/p$ where p is some divisor of L

$$(\phi_i, J\phi_i, J^2\phi_i, \dots, J^{l_i-1}\phi_i) .$$

Let us next consider the general form of the OPE of a simple current J and a primary field ϕ

$$J(z)\phi(w) \sim \frac{1}{(z-w)^{Q(\phi)}} \left([J] \times [\phi] \right)(w) , \quad (4.73)$$

where $Q(\phi)$ denotes the monodromy charge from Eq. (4.72). Since $[J] \times [\phi]$ may involve derivatives, the right-hand side may contain further factors of $(z-w)^n$ with $n \in \mathbb{Z}$ which are, however, not important for the present discussion. Furthermore, from Eq. (4.73), we see that when moving $J(z)$ around $\phi(w)$ counterclockwise, that is, sending $(z-w)$ to $e^{2\pi i}(z-w)$, $J(z)\phi(w)$ acquires the factor $\exp(-2\pi i Q(\phi))$ which explains the notation monodromy charge for $Q(\phi)$.

In order to gain further insight into the monodromy charge, let us note that from the general form of the OPE for quasi-primary fields (2.53), we infer that $h(J^2) \in \mathbb{Z}$ because $J(z)$ has integer conformal weight. For the monodromy charge (4.72) of the simple currents, we therefore obtain

$$Q(J) = 0 . \quad (4.74)$$

Next, we are going to compute the monodromy charge of $J\phi$ in two different ways. First, as illustrated in Fig. 4.6, we move $J(u)$ around $J(z)\phi(w)$ which leads to the monodromy $Q(J\phi)$. However, by deforming the contour as depicted on the

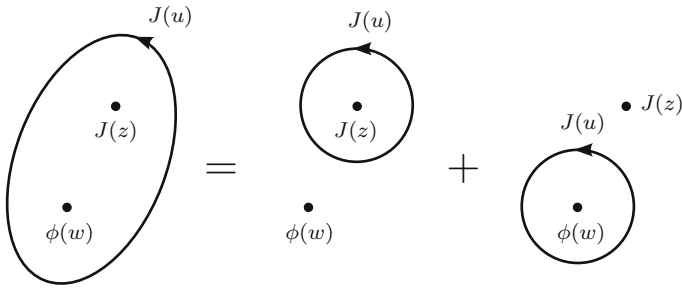

Fig. 4.6 Illustration for the computation of monodromies

right-hand side of Fig. 4.6, we can alternatively compute the monodromy of $J\phi$ by moving $J(u)$ around $J(z)$ and around $\phi(w)$ separately. Therefore, the monodromy charge satisfies

$$Q(J\phi) = Q(J) + Q(\phi) \stackrel{(4.74)}{=} Q(\phi) .$$

By iteration, we can conclude that all fields in the orbit of ϕ_i have the same monodromy charge, that is,

$$Q(\phi) = Q(J\phi) = Q(J^2\phi) = \dots .$$

Moreover, due to $[J]^L = [\mathbb{1}]$, it is clear that $Q(\phi) = Q(J^L\phi)$ and so the monodromy charges have to have the general form

$$Q(\phi_i) = \frac{t(\phi_i)}{L} \quad \text{with } t(\phi_i) \in \mathbb{Z} . \tag{4.75}$$

Note that the integers $t(\phi_i)$ can be different for each primary field ϕ_i and that we will not need the explicit form of $t(\phi_i)$ in the following.

Modular S-Transformation

We will now consider the modular S -transformation of characters in theories with simple currents. To do so, we introduce the short-hand notation

$$J^\alpha \phi_i =: (\alpha i) , \quad \sum_{(\alpha i)} = \sum_i \sum_{\alpha=0}^{l_i-1} . \tag{4.76}$$

Without derivation, we note that in order for the fusion algebra to respect the monodromy charge Q , the S -matrix has to have the form

$$S_{(\alpha i)(\delta n)} = \exp \left(2\pi i \left(Q(\phi_i) \delta + Q(\phi_n) \alpha \right) \right) S_{(0i)(0n)} . \tag{4.77}$$

In the following, we will now confirm that if the S -matrix is written in this way, indeed the monodromy charge is preserved. However, before doing so, let us observe that from the definition (4.76) we find $(\delta n) = (\delta + l_n, n)$ where l_n is the length of the orbit containing ϕ_n . For the S -matrix (4.77), this implies that

$$S_{(\alpha i)(\delta n)} = S_{(\alpha i)(\delta + l_n, n)} = e^{2\pi i Q(\phi_i) l_n} S_{(\alpha i)(\delta n)} .$$

Note that because of Eq. (4.75), for orbits with $l_n = L$ there is no ambiguity. But for short orbits with $l_i \neq L$, we can distinguish two cases

$$\begin{aligned} Q(\phi_i) l_n \in \mathbb{Z} &\quad \Rightarrow \quad \text{no restriction ,} \\ Q(\phi_i) l_n \notin \mathbb{Z} &\quad \Rightarrow \quad S_{(\alpha i)(\delta n)} = 0 . \end{aligned}$$

From this observation, we infer that sums over short orbits can be written in the following way:

$$\sum_{(\delta n)} S_{(\alpha i)(\delta n)} \dots = \sum_n \sum_{\delta=0}^{l_n-1} S_{(\alpha i)(\delta n)} \dots = \sum_n \frac{l_n}{L} \sum_{\delta=0}^{L-1} S_{(\alpha i)(\delta n)} \dots$$

where \dots stands either for other S -matrix elements or for characters $\chi_{(\delta n)}$.

Let us now confirm that the S -matrix (4.77) preserves the monodromy charge. To do so, we apply the Verlinde formula and compute the fusion coefficients as follows:

$$\begin{aligned} N_{(\alpha i)(\beta j)}^{(\gamma k)} &= \sum_{(\delta n)} \frac{S_{(\alpha i)(\delta n)} S_{(\beta j)(\delta n)} S_{(\delta n)(\gamma k)}^*}{S_{(00)(\delta n)}} \\ &= \sum_n \frac{S_{(0i)(0n)} S_{(0j)(0n)} S_{(0n)(0k)}^*}{S_{(00)(0n)}} e^{2\pi i Q(\phi_n)(\alpha + \beta - \gamma)} \frac{l_n}{L} \sum_{\delta=0}^{L-1} e^{2\pi i \delta (Q(\phi_i) + Q(\phi_j) - Q(\phi_k))} , \end{aligned} \quad (4.78)$$

where we used that $Q(\mathbb{1}) = 0$. Note that the sum over δ can be written as a δ -function modulo L in the following way:

$$\begin{aligned} \frac{l_n}{L} \sum_{\delta=0}^{L-1} e^{2\pi i \delta (Q(\phi_i) + Q(\phi_j) - Q(\phi_k))} &= l_n \sum_{\delta=0}^{L-1} \frac{1}{L} e^{\frac{2\pi i}{L} \delta (t(\phi_i) + t(\phi_j) - t(\phi_k))} \\ &= l_n \delta^{(L)}(t(\phi_i) + t(\phi_j) - t(\phi_k)) . \end{aligned} \quad (4.79)$$

Here, we have employed that the δ -function modulo L can be expressed as

$$\delta^{(L)}(n) = \sum_{p=0}^{L-1} e^{\frac{2\pi i}{L} p n} \quad \text{for } n \in \mathbb{Z} .$$

Using then Eq. (4.79) in Eq. (4.78), we see that the resulting fusion coefficients agree with the definition of a simple current. Expressing the δ -function again in terms of the monodromy charges, we find that for non-vanishing fusion coefficients we have to require

$$Q(\phi_k) = Q(\phi_i) + Q(\phi_j) .$$

Therefore, the form of the S -matrix (4.77) leads to fusion rules where the total monodromy charge on the left- and right-hand side of the fusion algebra agrees. That is, the fusion algebra respects the monodromy charge.

Modular Invariant Partition Function

Now we will consider the modular S -transformation of an orbit with length l_i and monodromy charge $Q(J^k \phi_i) \in \mathbb{Z}$ for every k . Using the explicit form of the S -matrix (4.77), we find

$$\begin{aligned} \sum_{\alpha=0}^{l_i-1} \chi_{(\alpha i)}\left(-\frac{1}{\tau}\right) &= \frac{l_i}{L} \sum_{\alpha=0}^{L-1} \chi_{(\alpha i)}\left(-\frac{1}{\tau}\right) = \frac{l_i}{L} \sum_{\alpha=0}^{L-1} \sum_{(\delta n)} S_{(\alpha i),(\delta n)} \chi_{(\delta n)}(\tau) \\ &= \frac{l_i}{L} \sum_{\alpha=0}^{L-1} \sum_{(\delta n)} \exp\left(2\pi i \left(Q(\phi_i) \delta + Q(\phi_n) \alpha\right)\right) S_{(0i)(0n)} \chi_{(\delta n)}(\tau) \\ &= \frac{l_i}{L} \sum_{(\delta n)} \sum_{\alpha=0}^{L-1} \exp\left(2\pi i Q(\phi_n) \alpha\right) \exp\left(2\pi i Q(\phi_i) \delta\right) S_{(0i)(0n)} \chi_{(\delta n)}(\tau) \\ &= \frac{l_i}{L} \sum_{(\delta n)} L \delta^{(1)}\left(Q(\phi_n)\right) S_{(0i)(0n)} \chi_{(\delta n)}(\tau) \\ &= \sum_{\substack{n \\ Q(\phi_n) \in \mathbb{Z}}} l_i S_{(0i)(0n)} \sum_{\delta=0}^{l_n-1} \chi_{(\delta n)}(\tau) , \end{aligned}$$

where we expressed the sum over α as a δ -function and employed that by assumption $Q(\phi_i) \in \mathbb{Z}$. Furthermore, the δ -sum runs over the length of the orbit containing ϕ_n . We have thus seen that orbits with $Q(\phi_i) \in \mathbb{Z}$ transform among themselves under modular S -transformations.

We finally come to the main result of this section. For each simple current of integer conformal dimension, one can define a new modular invariant partition function in the following way:

$$\mathcal{Z}_J(\tau, \bar{\tau}) = \frac{1}{\mathcal{N}} \sum_{\substack{(\alpha i) \\ Q(\phi_i) \in \mathbb{Z}}} \sum_{\beta=0}^{L-1} \chi_{(\alpha+\beta, i)}(\tau) \bar{\chi}_{(\alpha i)}(\bar{\tau}) , \quad (4.80)$$

where the normalisation constant \mathcal{N} is fixed by the requirement that the vacuum should only appear once in $\mathcal{Z}_J(\tau, \bar{\tau})$. Note that the sum over α runs from one to the length l_i of the orbit i , while the sum over β *always* runs over the maximal length L . Because of this sum, we obtain the extra factors of L/l_i in the partition function for the shorter orbits. Moreover, we remark that this construction can be generalised to initially non-diagonal partition functions with $M_{ij} \neq \delta_{ij}$ in Eq. (4.80).

Let us now prove the modular invariance of this partition function. We start by writing out the S -transform in terms of the S -matrix and employing the relation (4.77) as $S_{(\alpha+\beta, i)(\delta n)} = \exp(2\pi i \beta Q(\phi_n)) S_{(\alpha i)(\delta n)}$ to find

$$\begin{aligned} & \mathcal{Z}_J\left(-\frac{1}{\tau}, -\frac{1}{\bar{\tau}}\right) \\ &= \frac{1}{\mathcal{N}} \sum_{(\alpha i)} \delta^{(1)}\left(Q(\phi_i)\right) \sum_{\beta=0}^{L-1} \sum_{(\delta m)} S_{(\alpha+\beta, i), (\delta m)} \chi_{(\delta m)}(\tau) \sum_{(\epsilon n)} S_{(\alpha i), (\epsilon n)}^* \bar{\chi}_{(\epsilon n)}(\bar{\tau}) \\ &= \frac{1}{\mathcal{N}} \sum_{(\alpha i)} \frac{1}{L} \sum_{k=0}^{L-1} e^{-2\pi i Q(\phi_i)k} \sum_{\beta=0}^{L-1} \sum_{(\delta m)} e^{2\pi i (Q(\phi_i)\delta + Q(\phi_m)\beta)} S_{(\alpha i), (0m)} \chi_{(\delta m)}(\tau) \\ & \quad \times \sum_{(\epsilon n)} e^{-2\pi i Q(\phi_i)\epsilon} S_{(\alpha i), (0n)}^* \bar{\chi}_{(\epsilon n)}(\bar{\tau}) \\ &= \frac{1}{\mathcal{N}} \frac{1}{L} \sum_{k=0}^{L-1} \sum_{\beta=0}^{L-1} \sum_{(\delta m), (\epsilon n)} e^{2\pi i Q(\phi_m)\beta} \chi_{(\delta m)}(\tau) \bar{\chi}_{(\epsilon n)}(\bar{\tau}) \\ & \quad \times \sum_{(\alpha i)} e^{2\pi i Q(\phi_i)(\delta-k-\epsilon)} S_{(0m), (\alpha i)}^\dagger S_{(\alpha i), (0m)} \\ &= \frac{1}{\mathcal{N}} \frac{1}{L} \sum_{k=0}^{L-1} \sum_{\beta=0}^{L-1} \sum_{(\delta m), (\epsilon n)} e^{2\pi i Q(\phi_m)\beta} \chi_{(\delta m)}(\tau) \bar{\chi}_{(\epsilon n)}(\bar{\tau}) \sum_{(\alpha i)} S_{(0m), (\alpha i)}^\dagger S_{(\alpha i), (\delta-k-\epsilon, m)} . \end{aligned}$$

Using Eq. (4.54) we see that the last sum in the last line gives a δ -function setting $m = n$ and $(\delta - k - \epsilon) = 0$. Writing then the β sum over the remaining exponential again as a $\delta^{(1)}$ -function, we obtain

$$\mathcal{Z}_J\left(-\frac{1}{\tau}, -\frac{1}{\bar{\tau}}\right) = \frac{1}{\mathcal{N}} \sum_{k=0}^{L-1} \sum_{(\epsilon n)} \delta^{(1)}\left(Q(\phi_n)\right) \chi_{(k+\epsilon, n)}(\tau) \bar{\chi}_{(\epsilon n)}(\bar{\tau}) = \mathcal{Z}_J(\tau, \tau) ,$$

and so we have shown that the partition function (4.80) is invariant under modular S -transformations.

Example

As an example, let us consider a CFT with $\widehat{\mathfrak{su}}(2)_4$ Kač–Moody symmetry. This theory has five highest weight representations with characters denoted as $\chi_i(\tau)$, $i = 0, \dots, 4$. From Eq. (4.59), we determine the S -matrix to be of the following form:

$$S = \frac{1}{\sqrt{3}} \begin{pmatrix} \frac{1}{2} & \frac{\sqrt{3}}{2} & 1 & \frac{\sqrt{3}}{2} & \frac{1}{2} \\ \frac{\sqrt{3}}{2} & \frac{\sqrt{3}}{2} & 0 & -\frac{\sqrt{3}}{2} & -\frac{\sqrt{3}}{2} \\ 1 & 0 & -1 & 0 & 1 \\ \frac{\sqrt{3}}{2} & -\frac{\sqrt{3}}{2} & 0 & \frac{\sqrt{3}}{2} & -\frac{\sqrt{3}}{2} \\ \frac{1}{2} & -\frac{\sqrt{3}}{2} & 1 & -\frac{\sqrt{3}}{2} & \frac{1}{2} \end{pmatrix}. \tag{4.81}$$

Utilising then the explicit expression for the fusion coefficients (4.60), we find for instance that $N_{4,l}^m = \delta_{l+m,4}$ which implies that the field ϕ_4 is a simple current. Furthermore, it follows that $[J]^2 = \mathbb{1}$ and so the maximal length of the orbits is $L = 2$. Employing finally Eq. (4.71), the conformal dimension is easily found as $h_4 = 1$.

As we illustrated previously, the partition function should contain only characters of orbits with integer monodromy charge. In the present case we have $Q(\phi_l) = \frac{l}{2}$ for an orbit containing ϕ_l and so the possibilities which respect the condition above are

$$\tilde{\chi}_0 = \chi_0 + \chi_4, \quad \tilde{\chi}_2 = \chi_2.$$

Note that the second orbit has shorter length and is called a fixed point of the simple current construction. The S -matrix for these two orbits can be obtained from Eq. (4.81) and has the simple form

$$\tilde{S} = \frac{1}{\sqrt{3}} \begin{pmatrix} 1 & 2 \\ 1 & -1 \end{pmatrix}.$$

Note that \tilde{S} is not symmetric, which can be reconciled by “resolving” the short orbit. However, we will not explain this method here. The partition function is found using the general expression (4.80) to be of the following form:

$$\begin{aligned} \tilde{Z}_J(\tau, \bar{\tau}) &= \frac{1}{\mathcal{N}} \sum_{\beta=0}^1 \left(\sum_{\alpha=0}^1 \chi_{(\alpha+\beta,0)} \bar{\chi}_{(\alpha,0)} + \chi_{(\beta,2)} \bar{\chi}_{(0,2)} \right) \\ &= \chi_0 \bar{\chi}_0 + \chi_4 \bar{\chi}_4 + \chi_4 \bar{\chi}_0 + \chi_0 \bar{\chi}_4 + 2 \chi_2 \bar{\chi}_2 \\ &= |\tilde{\chi}_0|^2 + 2 |\tilde{\chi}_2|^2, \end{aligned}$$

where we fixed the normalisation constant to be $\mathcal{N} = 1$ because the vacuum representation χ_0 should only appear once. Writing this expression as

$$\tilde{Z}_J(\tau, \bar{\tau}) = \begin{pmatrix} \tilde{\chi}_0 \\ \tilde{\chi}_2 \end{pmatrix}^T \begin{pmatrix} 1 & 0 \\ 0 & 2 \end{pmatrix} \begin{pmatrix} \tilde{\chi}_0 \\ \tilde{\chi}_2 \end{pmatrix}$$

and computing $\tilde{S}^T M \tilde{S}^* = M$ with $M = \text{diag}(1, 2)$, we see that the partition function is indeed invariant under modular S -transformations.

Remark

The concept of simple currents can be generalised to the case $h(J) \neq \mathbb{Z}$ which does not lead to the orbit partition functions studied in this section, but instead to so-called *automorphism invariants* such as the D_{2n+1} series for $\widehat{\mathfrak{su}}(2)_{4n-2}$. However, not all modular invariants are obtained via simple currents, for instance the E_7 invariant for $\widehat{\mathfrak{su}}(2)_{16}$ cannot be constructed in this way. But the techniques covered in this section will become very valuable in Chap. 5 when constructing modular invariant partition functions corresponding to Calabi–Yau compactifications.

4.8 Additional Topics

Although not important for the rest of this course, in this section we illustrate two interesting questions in conformal field theory. This part can be omitted in a first reading.

4.8.1 Asymptotic Growth of States in RCFTs

For various applications of CFT, it is important to have an estimate on the asymptotic growth of the degeneracy of states in a partition function. In this section, we will investigate this point.

To start with, let us assume we have a (not necessarily unitary) Rational conformal field theory with central charge c and highest weight representations labelled by i of conformal dimension h_i . The characters corresponding to these HWRs have the form

$$\chi_i(\tau) = q^{h_i - \frac{c}{24}} \sum_{N \geq 0} P_i(N) q^N. \quad (4.82)$$

The question we want to ask is how the degeneracy of states $P(N)$ behaves for $N \gg 1$. To determine this behaviour, we apply a modular S -transformation to $\chi_i(\tau)$ to find

$$\chi_i(\tau) = \sum_j S_{ij} \chi_j\left(-\frac{1}{\tau}\right) = \sum_j S_{ij} e^{-\frac{2\pi i}{\tau}(h_j - \frac{c}{24})} \sum_{N \geq 0} P_j(N) e^{-\frac{2\pi i}{\tau} N}. \quad (4.83)$$

Next, we study $\chi_i(\tau)$ in the limit $\tau = i\tau_2$ with $\tau_2 \rightarrow 0^+$, that is, τ_2 goes to zero from above. Equation (4.83) then becomes

$$\chi_i(i\tau_2) \underset{\tau_2 \rightarrow 0^+}{\sim} S_{i,j_{\min}} e^{\frac{\pi}{12\tau_2}(c-24h_{\min})} \left(1 + \mathcal{O}\left(e^{-\frac{2\pi}{\tau_2}}\right)\right), \quad (4.84)$$

where h_{\min} denotes the minimal highest weight in the RCFT. For unitary theories, we have of course $h_{\min} = 0$. Thus, the exponential factor in Eq. (4.84) gives the leading order contribution in the $\tau_2 \rightarrow 0^+$ limit.

Now, we have to find $P(N)$ in Eq. (4.82) such that for $\tau_2 \rightarrow 0^+$, we obtain the same behaviour as in Eq. (4.84). To this end, we make the ansatz $P(N) \sim \exp(2\sqrt{N\alpha})$ and write Eq. (4.82) as

$$\begin{aligned} \chi_i(i\tau_2) &\underset{\tau_2 \rightarrow 0^+}{\sim} e^{-2\pi\tau_2(h_i - \frac{c}{24})} \sum_{N \geq 0} e^{2\sqrt{N\alpha}} e^{-2\pi\tau_2 N} \\ &\underset{\tau_2 \rightarrow 0^+}{\sim} \int_0^\infty dy \exp\left(-2\pi y + 2\sqrt{\frac{\alpha y}{\tau_2}}\right), \end{aligned}$$

where we have neglected subleading terms in the limit $\tau_2 \rightarrow 0^+$ and performed the change of variables $N\tau_2 \rightarrow y$ together with replacing the sum by an integral. Then, we complete a perfect square in the exponent and again change variables to $z = \sqrt{y} - \frac{1}{2\pi}\sqrt{\frac{\alpha}{\tau_2}}$ which gives

$$\begin{aligned} \chi_i(i\tau_2) &\sim \int_0^\infty dy \exp\left(-2\pi\left(\sqrt{y} - \frac{1}{2\pi}\sqrt{\frac{\alpha}{\tau_2}}\right)^2\right) \exp\left(\frac{\alpha}{2\pi\tau_2}\right) \\ &\sim \int_{-\left(\frac{\alpha}{4\pi^2\tau_2}\right)^{1/2}}^{\left(\frac{\alpha}{4\pi^2\tau_2}\right)^{1/2}} dz \left(z + \frac{1}{2\pi}\sqrt{\frac{\alpha}{\tau_2}}\right) e^{-2\pi z^2} \exp\left(\frac{\alpha}{2\pi\tau_2}\right). \end{aligned}$$

Let us now extract the leading order behaviour of this expression in the limit $\tau_2 \rightarrow 0^+$. Performing the integration for instance with the help of a computer algebra package, one finds that the contribution of the integral over z is always subleading compared to the exponential $e^{\frac{\alpha}{2\pi\tau_2}}$. But also at a less formal level, by changing the integration domain to $(-\infty, +\infty)$, we find

$$\begin{aligned} \chi_i(i\tau_2) &\sim \int_{-\infty}^{+\infty} dz \left(z + \frac{1}{2\pi}\sqrt{\frac{\alpha}{\tau_2}}\right) e^{-2\pi z^2} \exp\left(\frac{\alpha}{2\pi\tau_2}\right) \\ &\sim \frac{1}{\sqrt{\tau_2}} \exp\left(\frac{\alpha}{2\pi\tau_2}\right) \sim \exp\left(\frac{\alpha}{2\pi\tau_2}\right), \end{aligned}$$

where we performed a Gaussian integration. Therefore, our ansatz from above gives the same kind of divergence for $\tau_2 \rightarrow 0^+$ as Eq. (4.84) provided we identify $\alpha = \frac{\pi^2}{6}c_{\text{eff}}$ with the effective central charge defined as $c_{\text{eff}} = c - 24h_{\min}$. To summarise,

the asymptotic growth of the number of states in a highest weight representation of a RCFT with central charge c is of the form

$$P(N) \sim \exp\left(\pi \sqrt{\frac{2}{3}} c_{\text{eff}} N\right) \quad \text{where} \quad c_{\text{eff}} = c - 24 h_{\text{min}} .$$

This formula is often used in string theory for microstate counting for instance in computations of the statistical entropy of a stringy black hole.

4.8.2 Dilogarithm Identities

Let us mention one nice curiosity for the $\widehat{\mathfrak{su}}(2)_k$ unitary models with central charge $c = \frac{3k}{k+2}$ and highest weights $h = \frac{l(l+2)}{4(k+2)}$. Here, we will be satisfied with just stating the result which involves the so-called Rogers–Ramanujan identities whose derivation can be found in the literature. Let us start by first defining the Rogers dilogarithm in the following way:

$$L(z) = \text{Li}_2(z) + \frac{1}{2} \log(z) \log(1-z) ,$$

with the poly-logarithm $\text{Li}_2(z) = \sum_{n=1}^{\infty} \frac{z^n}{n^2}$ which is well defined for $z < 1$. The Rogers dilogarithm satisfies the relations

$$\begin{aligned} L(1-z) + L(z) &= L(1) , & L(z^2) &= 2L(z) - 2L\left(\frac{z}{1+z}\right) , \\ L(1) &= \frac{\pi^2}{6} , & L(0) &= 0 . \end{aligned}$$

Furthermore, it can be analytically continued to the region $z > 1$ by using $L(z) = 2L(1) - L(1/z)$ which implies that $\lim_{z \rightarrow \infty} L(z) = 2L(1)$.

Let us now turn to the modular S -matrix and the Verlinde formula. In particular, as mentioned in Sect. 4.3, we can diagonalise the fusion rules with the following entries in the diagonal matrix D :

$$D_{\lambda l} = \frac{S_{l\lambda}}{S_{0\lambda}} = \frac{\sin\left(\frac{\pi}{k+1}(l+1)(\lambda+1)\right)}{\sin\left(\frac{\pi}{k+2}(\lambda+1)\right)}$$

for $l, \lambda = 0, \dots, k$. Note that here we used the explicit form of the S -matrix for $\widehat{\mathfrak{su}}(2)_k$ given in Eq. (4.59). Without providing a derivation, we state that the following $k+1$ relations are satisfied for each $\lambda = 0, \dots, k$:

$$\frac{1}{L(1)} \sum_{l=1}^k L\left(\frac{1}{(D_{\lambda l})^2}\right) = c - 24h_{\lambda} + 6\lambda .$$

It is quite remarkable that the sum of dilogarithms evaluated at special irrational values adds up precisely to the rational defining data of a Rational conformal field theory. It was conjectured that similar dilogarithm identities hold for any RCFT and might eventually be a way or a piece in the puzzle towards a classification of RCFTs.

Further Reading

1. J. L. Cardy, “Operator content of two-dimensional conformally invariant theories,” *Nucl. Phys.* **B270** (1986) 186–204.
2. A. Cappelli, C. Itzykson, and J. B. Zuber, “Modular invariant partition functions in two-dimensions,” *Nucl. Phys.* **B280** (1987) 445–465.
3. L. J. Dixon, J. A. Harvey, C. Vafa, and E. Witten, “Strings on orbifolds,” *Nucl. Phys.* **B261** (1985) 678–686.
4. L. J. Dixon, D. Friedan, E. J. Martinec, and S. H. Shenker, “The conformal field theory of orbifolds,” *Nucl. Phys.* **B282** (1987) 13–73.
5. E. P. Verlinde, “Fusion rules and modular transformations in 2D conformal field theory,” *Nucl. Phys.* **B300** (1988) 360.
6. V. A. Fateev and A. B. Zamolodchikov, “Parafermionic currents in the two-dimensional conformal quantum field theory and selfdual critical points in $Z(n)$ invariant statistical systems,” *Sov. Phys. JETP* **62** (1985) 215–225.
7. D. Gepner and Z.-a. Qiu, “Modular invariant partition functions for parafermionic field theories,” *Nucl. Phys.* **B285** (1987) 423.
8. A. N. Schellekens and S. Yankielowicz, “Extended Chiral algebras and modular invariant partition functions,” *Nucl. Phys.* **B327** (1989) 673.
9. W. Nahm, A. Recknagel, and M. Terhoeven, “Dilogarithm identities in conformal field theory,” *Mod. Phys. Lett.* **A8** (1993) 1835–1848, hep-th/9211034.

Chapter 5

Supersymmetric Conformal Field Theory

In the previous chapters, we have studied conformal field theories with only bosonic or only fermionic fields. However, we can formulate CFTs containing both bosons and fermions which may exhibit new symmetries. For instance, there can be symmetries exchanging bosonic and fermionic fields called supersymmetries, which have been studied intensively in many instances. In fact, also two-dimensional conformal field theories can be generalised to respect supersymmetry. These so-called superconformal field theories (SCFT) naturally appear in string theory; in particular, it was shown that the pure bosonic string is unstable while a supersymmetric extension can be stable.

In the present chapter, we will give a brief introduction to superconformal field theories. But since many aspects are similar to bosonic CFTs, we will not present a detailed discussion at all instances. Instead, we assume the reader to be sufficiently accustomed to the structures of CFT that she or he will accept some straightforwardly generalised features without a detailed derivation.

In view of string theory, in this chapter we will discuss so-called $\mathcal{N} = 2$ SCFTs and so-called Gepner models in some length, which exhibit new structures important for compactifications of Superstring Theory. The Gepner model constructions are extremely powerful and are maybe one of the most impressive applications of conformal field theory at all. In particular, the metric on a Calabi–Yau manifold, on which the superstring is compactified on, in general is not known explicitly, and the non-linear sigma model governing the dynamics cannot be written down. Nevertheless, at particular points in the moduli space, the Gepner models provide exact solutions to the non-linear sigma model.

5.1 $\mathcal{N} = 1$ Superconformal Models

Let us start exploring $\mathcal{N} = 1$ superconformal field theories by considering the simplest imaginable model consisting of just the free boson $X(z, \bar{z})$ introduced in Sect. 2.9.1 and the free fermion $\psi(z, \bar{z})$ from Sect. 2.9.2. Here and in the following, we are going to focus on fermions in the Neveu–Schwarz sector, but the results for the Ramond sector are obtained along the same lines.

The $\mathcal{N} = 1$ Superconformal Extension of the Free Boson Theory

Since the free boson and free fermion theories are independent of each other, the energy–momentum tensor is simply the sum of the bosonic and the fermionic one

$$T(z) = \frac{1}{2} N(j j)(z) + \frac{1}{2} N(\psi \partial\psi)(z).$$

For convenience, here we have fixed the normalisation constants of the two-point functions from Sect. 2.9 to be +1 which has no implications for the rest of our calculations. As a next step, we expand the energy–momentum tensor in a Laurent series $T(z) = \sum_{m \in \mathbb{Z}} L_m z^{-m-2}$ in the usual way. This implies $L_m = L_m^{\text{bos.}} + L_m^{\text{ferm.}}$ leading to

$$\begin{aligned} L_m = & \frac{1}{2} \left(\sum_{k > -1} j_{m-k} j_k + \sum_{k \leq -1} j_k j_{m-k} \right) \\ & + \frac{1}{2} \left(\sum_{s > -\frac{3}{2}} (s + \frac{1}{2}) \psi_{m-s} \psi_s - \sum_{s \leq -\frac{3}{2}} (s + \frac{1}{2}) \psi_s \psi_{m-s} \right). \end{aligned} \quad (5.1)$$

The bosonic $L_m^{\text{bos.}}$ and the fermionic part $L_m^{\text{ferm.}}$ satisfy the Virasoro algebra with central charges $c = 1$ and $c = \frac{1}{2}$, respectively. Because these algebras are independent of each other, i.e. $[L_m^{\text{bos.}}, L_n^{\text{ferm.}}] = 0$, we see that Eq. (5.1) obeys the Virasoro algebra with central charge

$$c = 1 + \frac{1}{2} = \frac{3}{2}.$$

So far, we have not encountered new structures due to the combination of the free boson and free fermion CFT. However, out of the current $j(z) = i \partial X(z, \bar{z})$ and the fermion $\psi(z)$, we can build a new fermionic field written as

$$G(z) = N(j \psi)(z).$$

Here we have chosen the normalisation of $G(z)$ to be 1 which turns out to be convenient in the following. The normal ordered product is required to give a meaning to this expression at the quantum level, but since the free boson and the free fermion are independent of each other, their Laurent modes commute and so we can write

$$G(z) = \sum_{r \in \mathbb{Z} + \frac{1}{2}} G_r z^{-r - \frac{3}{2}} \quad \text{with} \quad G_r = \sum_{s \in \mathbb{Z} + \frac{1}{2}} j_{r-s} \psi_s. \quad (5.2)$$

Using then the definition of a conformal primary field from Eq. (2.45) and noting that $j(z)$ and $\psi(z)$ are primary fields of conformal dimension $h = 1$ and $h = \frac{1}{2}$, respectively, we calculate

$$\begin{aligned}
[L_m, G_r] &= \sum_{s \in \mathbb{Z} + \frac{1}{2}} \left([L_m^{\text{bos.}}, j_{r-s}] \psi_s + j_{r-s} [L_m^{\text{ferm.}}, \psi_s] \right) \\
&= \sum_{s \in \mathbb{Z} + \frac{1}{2}} \left(-(r-s) j_{m+r-s} \psi_s + j_{r-s} \left(-\frac{m}{2} - s \right) \psi_{m+s} \right) \\
&= \left(\frac{m}{2} - r \right) G_{m+r},
\end{aligned} \tag{5.3}$$

where from the second to the last line we changed the summation $s \rightarrow s - m$ in the last term. Note that by comparing Eqs. (5.3) with (2.45), we see that $G(z)$ is a primary field of conformal dimension $h = \frac{3}{2}$.

After having determined the relation between L_m and G_r , let us also calculate the anti-commutator of two Laurent modes G_r and G_s . We start again by using Eq. (5.2) to write explicitly

$$\begin{aligned}
\{G_r, G_s\} &= \sum_{p, q \in \mathbb{Z} + \frac{1}{2}} \{j_{r-p} \psi_p, j_{s-q} \psi_q\} \\
&= \sum_{p, q \in \mathbb{Z} + \frac{1}{2}} \left(j_{r-p} j_{s-q} \{\psi_p, \psi_q\} + [j_{s-q}, j_{r-p}] \psi_q \psi_p \right) \\
&= \sum_{p \in \mathbb{Z} + \frac{1}{2}} \left(j_{r-p} j_{s+p} + (p-r) \psi_{r+s-p} \psi_p \right).
\end{aligned} \tag{5.4}$$

Next, we will bring these sums into a form which can be expressed in terms of L_m and G_r . To do so, we have to carefully arrange them into normal ordered expressions in the following way:

$$\begin{aligned}
\{G_r, G_s\} &= \sum_{p > -1-s} j_{r-p} j_{s+p} + \sum_{p \leq -1-s} \left(j_{s+p} j_{r-p} + [j_{r-p}, j_{s+p}] \right) \\
&\quad + \sum_{p > -\frac{3}{2}} \left(p + \frac{1}{2} \right) \psi_{r+s-p} \psi_p + \sum_{p \leq -\frac{3}{2}} \left(p + \frac{1}{2} \right) \left(-\psi_p \psi_{r+s-p} + \{\psi_{r+s-p}, \psi_p\} \right) \\
&\quad - \sum_{p > -\frac{1}{2}} \left(r + \frac{1}{2} \right) \psi_{r+s-p} \psi_p - \sum_{p \leq -\frac{1}{2}} \left(r + \frac{1}{2} \right) \left(-\psi_p \psi_{r+s-p} + \{\psi_{r+s-p}, \psi_p\} \right) \\
&= 2 L_{r+s}^{\text{bos.}} + \sum_{p \leq -\frac{1}{2}} (r-p) \delta_{r+s,0} - \sum_{p=-s}^{-\frac{1}{2}} (r-p) \delta_{r+s,0} + 2 L_{r+s}^{\text{ferm.}} \\
&\quad + \sum_{p \leq -\frac{1}{2}} \left(p + \frac{1}{2} \right) \delta_{r+s,0} - (r + \frac{1}{2}) N(\psi \psi)_{r+s} - \sum_{p \leq -\frac{1}{2}} \left(r + \frac{1}{2} \right) \delta_{r+s,0}.
\end{aligned}$$

We then recall from Sect. 2.9.2 that the normal ordered product of two identical fermions vanishes and we note that the sums with summation index $p \leq -\frac{1}{2}$ cancel among each other. After combining $L_{r+s}^{\text{bos.}}$ and $L_{r+s}^{\text{ferm.}}$ into the Laurent mode of the total energy-momentum tensor, we are left with computing

$$\sum_{p=-s}^{-\frac{1}{2}} (r-p) \delta_{r+s,0} = \sum_{n=0}^{s-\frac{1}{2}} (n - (s - \frac{1}{2})) \delta_{r+s,0} = -\frac{1}{2} \left(s^2 - \frac{1}{4} \right) \delta_{r+s,0} ,$$

which we utilise to arrive at

$$\{G_r, G_s\} = 2L_{r+s} + \frac{1}{2} \left(r^2 - \frac{1}{4} \right) \delta_{r+s,0} . \quad (5.5)$$

An Alternative Way to Determine Eq. (5.5)

In the previous paragraph, we have employed the definition of $G(z)$ as well as the algebra of the j_n and ψ_r modes to obtain the anti-commutation relations (5.5). However, utilising the general structure of quasi-primary fields studied in Sect. 2.6.3 can help to shorten such computations considerably.

In particular, from Eq. (5.3) we know that $G(z)$ is a primary field of conformal dimension $h = \frac{3}{2}$. Generalising formula (2.54) from Sect. 2.6.3 to fermionic fields, we can determine the anti-commutator of two $G(z)$ modes to be of the form

$$\{G_r, G_s\} = C_{GG}^L p_{\frac{3}{2}, \frac{3}{2}, 2}(r, s) L_{r+s} + d_{GG} \delta_{r+s,0} \left(r + \frac{1}{2} \right) .$$

In order to arrive at this equation, we have recalled the fact that the (anti-)commutator of two identical fields contains only fields of even conformal dimension on the right-hand side. Next, from Eq. (2.56) we determine

$$d_{GG} = \langle 0 | G_{+\frac{3}{2}} G_{-\frac{3}{2}} | 0 \rangle = \langle 0 | \psi_{\frac{1}{2}} j_1 j_{-1} \psi_{-\frac{1}{2}} | 0 \rangle = 1 ,$$

and from Eq. (2.55) we compute $p_{\frac{3}{2}, \frac{3}{2}, 2}(r, s) = 1$ as well as $p_{2, \frac{3}{2}, \frac{3}{2}}(r, s) = \frac{1}{3}(m-2r)$. The latter expression allows us to fix $C_{LG}^G = \frac{3}{2}$ via Eq. (5.3) and so, recalling from Eq. (2.58) that $d_{LL} = c/2$, we can calculate the last missing structure constant in the following way:

$$C_{GG}^L = C_{GGL} d_{LL}^{-1} = C_{LG}^G d_{GG} d_{LL}^{-1} = \frac{3}{2} \cdot 1 \cdot \frac{4}{3} = 2 .$$

Note that here we employed that $c = 3/2$. In conclusion, we have determined the anti-commutation relations (5.5) in a less involved way.

The $\mathcal{N} = 1$ Super Virasoro Algebra

So far, we have studied in detail the algebra of the $\mathcal{N} = 1$ superconformal extension of the free boson theory. The structure we have found is an example for an $\mathcal{N} = 1$ super Virasoro algebra where the specification $\mathcal{N} = 1$ refers to the fact that there is one so-called superpartner for each field. For instance, in the last paragraph the free fermion is the superpartner of the free boson and $G(z)$ is the superpartner of $T(z)$.

The defining relations for a general $\mathcal{N} = 1$ super Virasoro algebra in terms of the modes G_r and L_m read

$$\begin{aligned} [L_m, L_n] &= (m - n) L_{m+n} + \frac{c}{12} (m^3 - m) \delta_{m+n,0} , \\ [L_m, G_r] &= \left(\frac{m}{2} - r \right) G_{m+r} , \\ \{G_r, G_s\} &= 2 L_{r+s} + \frac{c}{3} \left(r^2 - \frac{1}{4} \right) \delta_{r+s,0} . \end{aligned} \tag{5.6}$$

The first line characterises the bosonic Virasoro algebra, the second line is the statement that $G(z)$ is a primary field of conformal dimension $\frac{3}{2}$ and the last line is the defining relation for the supersymmetric generalisation of the Virasoro algebra. Note that this algebra is also valid for the Ramond sector where $G(z)$ is periodic and the Laurent modes are integer labelled.

Mathematically, the relations (5.6) determine an infinite-dimensional super Lie algebra. A finite algebra contained in the infinite-dimensional one is generated by $\{L_0, L_{\pm 1}, G_{\pm \frac{1}{2}}\}$ and turns out to be $\mathfrak{osp}(1|2)$. The corresponding super group $OSP(1|2)$ plays the same role for SCFTs as $SL(2, \mathbb{C})/\mathbb{Z}_2$ does for usual CFTs. Analogously to Sect. 2.6, $OSP(1|2)$ can then be used to constrain the OPE for super quasi-primary conformal fields.

Superspace

We will now present the so-called superspace formalism which allows us to express certain equations for superconformal theories in a more compact way. However, we will be brief and focus only on the structure needed here.

To start with, let us introduce the superspace via the pair $Z = (z, \Theta)$ where $z \in \mathbb{C}$ is an ordinary variable and Θ is a so-called Grassmann variable with the property

$$\{\Theta, \Theta\} = 0 ,$$

from which it immediately follows that $\Theta^2 = 0$. We define the derivative on superspace in the following way:

$$D = \partial_{\Theta} + \Theta \partial_z ,$$

and we observe that $D^2 = \partial_z$. Furthermore, we introduce the superfield $\Phi(Z)$ written in terms of its bosonic and fermionic components $\phi(z)$ and $\psi(z)$ as

$$\Phi(Z) = \phi(z) + \Theta \psi(z) .$$

A particular superfield is the combination of the energy–momentum tensor $T(z)$ together with its superpartner $G(z)$ expressed as

$$\mathcal{L}(Z) = \frac{1}{2} G(z) + \Theta T(z) .$$

Without derivation, we now note that the $\mathcal{N} = 1$ super Virasoro algebra (5.6) is encoded in the following OPE of $\mathcal{L}(Z)$ with itself:

$$\mathcal{L}(Z_1) \mathcal{L}(Z_2) = \frac{c/6}{Z_{12}^3} + \frac{\frac{3}{2} \Theta_{12} \mathcal{L}(Z_2)}{Z_{12}^2} + \frac{\frac{1}{2} D\mathcal{L}(Z_2)}{Z_{12}} + \frac{\Theta_{12} D^2\mathcal{L}(Z_2)}{Z_{12}} + \dots , \quad (5.7)$$

where Z_{12} is the superinterval defined as $Z_{12} = z_1 - z_2 - \Theta_1\Theta_2$ and Θ_{12} stands for $\Theta_{12} = \Theta_1 - \Theta_2$. Separating the Θ -dependent terms by using $\{\Theta, G\} = 0$, we recover the $\mathcal{N} = 1$ algebra (5.6) from the super OPE (5.7). In a similar way, the definition of a super primary field is given by

$$\mathcal{L}(Z_1) \Phi(Z_2) = \frac{\Delta \Theta_{12} \Phi(Z_2)}{Z_{12}^2} + \frac{\frac{1}{2} D\Phi(Z_2)}{Z_{12}} + \frac{\Theta_{12} D^2\Phi(Z_2)}{Z_{12}} + \dots ,$$

where Δ is the superconformal dimension of $\Phi(Z)$ related to the component fields as $h_\phi = \Delta$ and $h_\psi = \Delta + \frac{1}{2}$. Separating again the Θ -dependent part, we find for the Laurent modes the following equations defining an $\mathcal{N} = 1$ super primary field:

$$\begin{aligned} [L_m, \phi_n] &= ((h-1)m-n)\phi_{m+n} , & [G_r, \phi_n] &= 2\psi_{n+r} , \\ [L_m, \psi_r] &= ((h-\frac{1}{2})m-r)\psi_{m+r} , & \{G_r, \psi_s\} &= (\frac{r}{2}-s)\phi_{r+s} . \end{aligned}$$

If these relations are only satisfied for the $OSP(1|2)$ subalgebra with $m = -1, 0, 1$ and $r = -1/2, 1/2$, the superfield is called super quasi-primary.

Note that the structure we obtained here is very similar to the bosonic case. As we have mentioned at the beginning of the chapter, we did not present a derivation of these results in full detail but only gave an outline of how they are obtained.

Highest Weight States

Let us also define an $\mathcal{N} = 1$ superconformal highest weight state in analogy to the bosonic case. Concretely, if a state $|h\rangle$ satisfies

$$\begin{aligned} L_n|h\rangle &= 0 & \text{for } n > 0 , \\ G_r|h\rangle &= 0 & \text{for } r > 0 , \end{aligned} \quad (5.8)$$

it is called a superconformal highest weight state. In a similar way as for the Virasoro algebra, one can then study highest weight representations of the $\mathcal{N} = 1$ super Virasoro algebra. As it turns out, in the regime $0 < c < \frac{3}{2}$ unitary highest weight representations are possible only for the following discrete values of the central charge:

$$c = \frac{3}{2} \left(1 - \frac{8}{(m+2)(m+4)} \right). \tag{5.9}$$

Remarks

Let us conclude our brief discussion of $\mathcal{N} = 1$ superconformal field theories with some remarks.

- Using $m = 1$ in Eq. (5.9), we obtain $c = \frac{7}{10}$ which is the central charge of the tri-critical Ising model mentioned at the end of Sect. 2.10. This observation indicates that the tri-critical Ising model is actually supersymmetric.
- A concrete coset realisation leading to the discrete series (5.9) of the $\mathcal{N} = 1$ super Virasoro algebra is given by

$$\frac{\widehat{\mathfrak{su}}(2)_k \times \widehat{\mathfrak{su}}(2)_2}{\widehat{\mathfrak{su}}(2)_{k+2}}. \tag{5.10}$$

Similarly as in Chap. 4, this realisation can be used to determine the characters, the modular S -matrix and the fusion rules of the $\mathcal{N} = 1$ super Virasoro algebra.

- As in Sect. 3.7, one can study extensions of the super Virasoro algebra by chiral super primary fields of conformal dimension Δ . This leads to the notion of a super \mathcal{W} algebra denoted as

$$S\mathcal{W} \left(\frac{3}{2}, \Delta_1, \dots, \Delta_N \right).$$

5.2 $\mathcal{N} = 2$ Superconformal Models

In the last section, we have studied $\mathcal{N} = 1$ superconformal field theories where each field has precisely one superpartner. However, especially for applications to string theory, $\mathcal{N} = 2$ superconformal theories with two superpartners for each field are much more important. This will be the subject of the present section.

The $\mathcal{N} = 2$ Superconformal Extension of the Free Boson Theory

Let us again start with the example of the free boson. We define a *complex* free boson $\Phi(z, \bar{z})$ in terms of the two real fields $X^{(1,2)}(z, \bar{z})$ in the following way:

$$\Phi(z, \bar{z}) = \frac{1}{\sqrt{2}} \left(X^{(1)}(z, \bar{z}) + i X^{(2)}(z, \bar{z}) \right),$$

and similarly for a complex free fermion $\Psi(z)$. Because the free boson itself is not an appropriate field in a conformal field theory, as usual, we will make use of the

corresponding currents $j(z) = i\partial\Phi(z, \bar{z})$ and $\bar{j}(\bar{z}) = i\bar{\partial}\Phi(z, \bar{z})$. Focussing then only on the holomorphic part, the fields of interest are

$$(i\partial\Phi)(z) = \frac{1}{\sqrt{2}}\left(j^{(1)}(z) + i j^{(2)}(z)\right), \quad \Psi(z) = \frac{1}{\sqrt{2}}\left(\psi^{(1)}(z) + i \psi^{(2)}(z)\right). \quad (5.11)$$

In order to avoid potential confusion with our notation, let us emphasise that $j^{(1,2)}(z)$ are the holomorphic currents for $X^{(1,2)}(z, \bar{z})$ and that $\bar{\Psi}(z)$ and $\partial\bar{\Phi}(z)$ denote the complex conjugate of $\Psi(z)$ and $\partial\Phi(z)$, respectively; however, they have no relation with the anti-holomorphic part depending solely on the variable \bar{z} .

The energy–momentum tensor for the present theory is again the sum of each individual CFT because these are independent of each other. We can thus write $T(z)$ in terms of the complex fields (5.11) in the following way:

$$T(z) = -N(\partial\Phi\partial\bar{\Phi})(z) + \frac{1}{2}N(\Psi\partial\bar{\Psi})(z) + \frac{1}{2}N(\bar{\Psi}\partial\Psi)(z).$$

The Laurent modes L_m of the total energy–momentum tensor satisfy the usual Virasoro algebra since this algebra is satisfied by each of the individual theories. Therefore, the central charge is computed as

$$c = 1 + 1 + \frac{1}{2} + \frac{1}{2} = 3.$$

Next, we recall from p. 63 that the theory of a complex free fermion $\Psi(z)$ contains a field of conformal dimension $h = 1$ expressed in the following way:

$$j(z) = -N(\Psi\bar{\Psi})(z). \quad (5.12)$$

Because we have already studied the algebra of this current, we can be brief and just quote the results. Using that the two fermionic theories anti-commute, the Laurent modes of $j(z)$ are written as

$$j_n = +iN(\psi^{(1)}\psi^{(2)})_n = -i\sum_{s\in\mathbb{Z}+\frac{1}{2}}\psi_{n-s}^{(1)}\psi_s^{(2)},$$

where we consider the fermions to be in the Neveu–Schwarz sector. Noting then that $[L_m^{\text{bos.}}, \psi_r^{(1,2)}] = 0$ and employing Eq. (2.114), we find for the commutation relations that

$$[j_m, j_n] = m\delta_{m+n,0} \quad \text{and} \quad [L_m, j_n] = -n j_{m+n}.$$

We proceed in analogy to the previous section where we found a new fermionic field $G(z)$. In the present case, it turns out that we can construct two such fields in the following way:

$$G^+(z) = \sqrt{2} i N (\partial \bar{\Phi} \Psi)(z), \quad G^-(z) = \sqrt{2} i N (\partial \Phi \bar{\Psi})(z), \quad (5.13)$$

whose sum takes the form $G^+(z) + G^-(z) = \frac{1}{\sqrt{2}} (G^{(1)}(z) + G^{(2)}(z))$. Actually, there are four independent combinations of a complex free boson with a complex free fermion. However, the remaining two choices decouple from the algebra, that is, they commute with every element of the $\mathcal{N} = 2$ algebra. For the expansion of $G^+(z)$ and $G^-(z)$ into a Laurent series, we note that the bosonic and fermionic theories commute to find

$$G_r^\pm = \frac{1}{\sqrt{2}} \sum_{s \in \mathbb{Z} + \frac{1}{2}} (j_{r-s}^{(1)} \mp i j_{r-s}^{(2)}) (\psi_s^{(1)} \pm i \psi_s^{(2)}).$$

Let us now explore the relations between $G^\pm(z)$ and the energy–momentum tensor as well as the current (5.12). Employing that $j^{(1,2)}(z)$ are primary fields of conformal dimension $h = 1$ and that $\psi^{(1,2)}(z)$ have dimension $h = \frac{1}{2}$, we find along the same lines as in the previous section that

$$[L_m, G_r^\pm] = \left(\frac{m}{2} - r\right) G_{m+r}^\pm.$$

From this we see that $G^+(z)$ and $G^-(z)$ are primary fields of conformal dimension $h = \frac{3}{2}$. With respect to the current $j(z)$ defined in Eq. (5.12), we compute the charge of $G^\pm(z)$ as follows:

$$[j_m, G_r^\pm] = \pm G_{m+r}^\pm.$$

We thus see that the fields $G^\pm(z)$ carry charge $+1$ and -1 , respectively, with respect to $j(z)$. Finally, let us determine the anti-commutator between two modes of $G^\pm(z)$. Performing a calculation along similar lines as above, we arrive at

$$\begin{aligned} \{G_r^+, G_s^+\} &= \{G_r^-, G_s^-\} = 0, \\ \{G_r^+, G_s^-\} &= 2L_{r+s} + (r-s)j_{r+s} + \left(r^2 - \frac{1}{4}\right)\delta_{r+s,0}. \end{aligned}$$

The $\mathcal{N} = 2$ Superconformal Algebra

After having studied the example of the $\mathcal{N} = 2$ superconformal extension of the free boson, let us now generalise the appearing structure and write down the general form of the $\mathcal{N} = 2$ superconformal algebra. In particular, we express this algebra in terms of the Laurent modes L_m of the energy–momentum tensor, its superpartners G_r^\pm and in terms of the modes j_n of a $U(1)$ current. For half-integer moding of G_r^\pm , this algebra is also known as the Neveu–Schwarz algebra while for integer moded G_r^\pm , it is called the Ramond algebra. Concretely, we have

$$\begin{aligned}
[L_m, L_n] &= (m-n)L_{m+n} + \frac{c}{12}(m^3 - m)\delta_{m+n,0}, \\
[L_m, j_n] &= -n j_{m+n}, \\
[L_m, G_r^\pm] &= \left(\frac{m}{2} - r\right) G_{m+r}^\pm, \\
[j_m, j_n] &= \frac{c}{3} m \delta_{m+n,0}, \\
[j_m, G_r^\pm] &= \pm G_{m+r}^\pm, \\
\{G_r^+, G_s^-\} &= 2L_{r+s} + (r-s)j_{r+s} + \frac{c}{3}\left(r^2 - \frac{1}{4}\right)\delta_{r+s,0}, \\
\{G_r^+, G_s^+\} &= \{G_r^-, G_s^-\} = 0.
\end{aligned} \tag{5.14}$$

The first three equations of Eq. (5.14) state the usual Virasoro algebra and that $j(z)$ and $G^\pm(z)$, respectively, are primary fields of conformal dimension $h = 1$ and $h = \frac{3}{2}$. The next two relations specify a $U(1)$ current algebra and that $G^\pm(z)$ has $j(z)$ charge ± 1 . Finally, the last two lines are the relations among the fields $G^\pm(z)$.

From Eq. (5.14) we infer that the Cartan subalgebra of the $\mathcal{N} = 2$ super Virasoro algebra, that is the maximal set of commuting operators, is generated by L_0 and j_0 . Therefore, these operators can be diagonalised simultaneously and so each state in the Hilbert space carries two labels determined as

$$L_0 |h, q\rangle = h |h, q\rangle, \quad j_0 |h, q\rangle = q |h, q\rangle. \tag{5.15}$$

Note that in the following, we will frequently refer to the charge q of a state with respect to the $U(1)$ current of the $\mathcal{N} = 2$ superconformal algebra.

Representation Theory of the $\mathcal{N} = 2$ Super Virasoro Algebra

Let us now turn to the representation theory of the $\mathcal{N} = 2$ super Virasoro algebra. Due to the $U(1)$ current generically present in such a theory and the resulting extended Cartan subalgebra, the representation theory is different from the $\mathcal{N} = 0$ and $\mathcal{N} = 1$ cases. Without going into detail, we simply state that there exists a discrete series of rational unitary models in the regime $0 < c < 3$ given by

$$c = \frac{3k}{k+2}, \quad k \geq 1. \tag{5.16}$$

Note that, in contrast to the usual $\mathcal{N} = 0$ Virasoro algebra, no rational non-unitary models such as Eq. (2.120) are known.

Next, for each value of k in the unitary series (5.16), there exists a finite number of highest weight representations $\phi_{m,s}^l$ which are specified by their conformal weight and j_0 charge in the following way:

$$\boxed{h_{m,s}^l = \frac{l(l+2) - m^2}{4(k+2)} + \frac{s^2}{8}, \quad q_{m,s} = -\frac{m}{k+2} + \frac{s}{2}.} \quad (5.17)$$

The constraints on the integers l , m and s take the following form:

$$0 \leq l \leq k, \quad 0 \leq |m - s| \leq l, \quad s = \begin{cases} 0, 2 & \text{Neveu-Schwarz sector,} \\ \pm 1 & \text{Ramond sector,} \end{cases}$$

and s is defined only modulo 4 while m is defined modulo $2(k+2)$. Given these restrictions on (l, m, s) , one finds a \mathbb{Z}_2 identification which relates highest weight representations as

$$\phi_{m,s}^l \sim \phi_{m+k+2, s+2}^{k-l}.$$

This reflection symmetry can be used to bring (l, m, s) into the regime $0 \leq |m - s| \leq l$.

Partition Function of the $\mathcal{N} = 2$ Extension of the Free Boson

Let us now determine the partition function for the example of the $\mathcal{N} = 2$ superconformal extension of the free boson theory studied at the beginning of this section. Similar to the non-supersymmetric case, the partition function is defined via Eq. (4.10). By combining the result of the free boson (4.14) with that of the free fermion (4.44), we obtain

$$\mathcal{Z}_{\mathcal{N}=2}(\tau, \bar{\tau}) = \frac{1}{4} \frac{1}{|\eta(\tau)|^4} \left(\left| \frac{\vartheta_3}{\eta} \right|^2 + \left| \frac{\vartheta_4}{\eta} \right|^2 + \left| \frac{\vartheta_2}{\eta} \right|^2 \right), \quad (5.18)$$

where the squares are due to the presence of two real bosons and two real fermions, respectively.

However, let us observe the following relations among the Θ -functions introduced in Eq. (4.24) and the ϑ -functions given on p. 137:

$$\begin{aligned} \Theta_{0,2}(\tau) &= \frac{1}{2} (\vartheta_3(\tau) + \vartheta_4(\tau)), & \Theta_{+1,2}(\tau) &= \frac{1}{2} (\vartheta_2(\tau) + i \vartheta_1(\tau)), \\ \Theta_{2,2}(\tau) &= \frac{1}{2} (\vartheta_3(\tau) - \vartheta_4(\tau)), & \Theta_{-1,2}(\tau) &= \frac{1}{2} (\vartheta_2(\tau) - i \vartheta_1(\tau)). \end{aligned} \quad (5.19)$$

These expressions together with the fact that $\vartheta_1(\tau)$ is identically zero allow us to rewrite the partition function (5.18) in the following way:

$$\mathcal{Z}_{\mathcal{N}=2}(\tau, \bar{\tau}) = \frac{1}{|\eta(\tau)|^4} \left(\left| \frac{\Theta_{0,2}}{\eta} \right|^2 + \left| \frac{\Theta_{2,2}}{\eta} \right|^2 + \left| \frac{\Theta_{+1,2}}{\eta} \right|^2 + \left| \frac{\Theta_{-1,2}}{\eta} \right|^2 \right), \quad (5.20)$$

and by comparing with Eq. (4.33), we see that the terms in the parenthesis constitute the $\widehat{\mathfrak{u}}(1)_2$ partition function. However, we know from Sect. 3.4 that two real fermions satisfy an $\widehat{\mathfrak{so}}(2)_1$ Kač–Moody algebra. Guided by this observation, we state that the characters for the $\widehat{\mathfrak{so}}(2)_1$ theory take the following form:

$$\begin{aligned}
 \chi_O^{(0,0)}(\tau) &= \frac{\Theta_{0,2}(\tau)}{\eta(\tau)} & (h, q) &= (0, 0), \\
 \chi_V^{(\frac{1}{2},1)}(\tau) &= \frac{\Theta_{2,2}(\tau)}{\eta(\tau)} & (h, q) &= (\frac{1}{2}, 1), \\
 \chi_S^{(\frac{1}{8},+\frac{1}{2})}(\tau) &= \frac{\Theta_{+1,2}(\tau)}{\eta(\tau)} & (h, q) &= (\frac{1}{8}, +\frac{1}{2}), \\
 \chi_C^{(\frac{1}{8},-\frac{1}{2})}(\tau) &= \frac{\Theta_{-1,2}(\tau)}{\eta(\tau)} & (h, q) &= (\frac{1}{8}, -\frac{1}{2}),
 \end{aligned} \tag{5.21}$$

where the superscripts on χ denote the conformal weight h and the charge q with respect to the current (5.12). In terms of these characters, the partition function (5.19) then reads

$$\mathcal{Z}_{\mathcal{N}=2}(\tau, \bar{\tau}) = \frac{1}{|\eta(\tau)|^4} \left(\left| \chi_O^{(0,0)} \right|^2 + \left| \chi_V^{(\frac{1}{2},1)} \right|^2 + \left| \chi_S^{(\frac{1}{8},+\frac{1}{2})} \right|^2 + \left| \chi_C^{(\frac{1}{8},-\frac{1}{2})} \right|^2 \right). \tag{5.22}$$

Given the characters (5.21), it is straightforward to compute the modular S -matrix employing the modular properties of the Θ -functions. In particular, one finds

$$S^{\widehat{\mathfrak{so}}(2)_1} = \frac{1}{2} \begin{pmatrix} 1 & 1 & 1 & 1 \\ 1 & 1 & -1 & -1 \\ 1 & -1 & -i & +i \\ 1 & -1 & +i & -i \end{pmatrix}, \tag{5.23}$$

where this matrix is understood as acting on the vector $\chi = (\chi_O, \chi_V, \chi_S, \chi_C)^T$. From the modular S -matrix, we can also determine the fusion rules of $\widehat{\mathfrak{so}}(2)_1$ via the Verlinde formula (4.55) to be of the following form:

$$\begin{aligned}
 [V] \times [V] &= [O], & [S] \times [S] &= [V], & [C] \times [C] &= [V], \\
 [S] \times [C] &= [O], & [S] \times [V] &= [C], & [C] \times [V] &= [S].
 \end{aligned} \tag{5.24}$$

Remark

Let us finally remark that all notations from ordinary CFT can be generalised to $\mathcal{N} = 2$ superconformal field theories, for instance, we can study $\mathcal{N} = 2$ super

primaries, the $\mathcal{N} = 2$ super OPE, $\mathcal{N} = 2$ super normal ordered products and $\mathcal{N} = 2$ super \mathcal{W} algebras.

5.3 Chiral Ring

After having introduced $\mathcal{N} = 2$ superconformal field theories, let us note that such theories have distinctive new features which are not present for the cases with $\mathcal{N} = 1$ or $\mathcal{N} = 0$ supersymmetry. These are the chiral ring and the spectral flow, respectively, which we will study in the following two sections.

Chiral Primary Fields

We begin with the definition of chiral and anti-chiral states in the Neveu–Schwarz sector of an $\mathcal{N} = 2$ superconformal field theory.

Definition 1. States $|h, q\rangle$ in the Neveu–Schwarz sector of the Hilbert space of an $\mathcal{N} = 2$ SCFT satisfying $G_{-1/2}^+ |h, q\rangle = 0$ are called (left-)chiral, while states satisfying $G_{-1/2}^- |h, q\rangle = 0$ are called (left-)anti-chiral.

Note that the adjective *left* refers to the holomorphic sector of the $\mathcal{N} = 2$ superconformal algebra while *right* would correspond to the anti-holomorphic part with $\overline{G}_{-1/2}^\pm$ instead of $G_{-1/2}^\pm$. However, in the following we will focus on the holomorphic sector of the theory and usually omit the additional specification *left*. Next, $\mathcal{N} = 2$ super primary states are defined similarly to the $\mathcal{N} = 1$ case (5.8) via the following equations:

$$\boxed{G_{n+\frac{1}{2}}^+ |h, q\rangle = G_{n+\frac{1}{2}}^- |h, q\rangle = 0 \quad \text{for } n \geq 0.} \quad (5.25)$$

After having given these definitions, let us now deduce some properties of chiral primary states.

- With the help of the superconformal algebra (5.14) and Eq. (5.15), we evaluate the following two anti-commutators:

$$\begin{aligned} \{G_{-\frac{1}{2}}^+, G_{+\frac{1}{2}}^-\} |h, q\rangle &= (2L_0 - j_0) |h, q\rangle = (2h - q) |h, q\rangle, \\ \{G_{+\frac{1}{2}}^+, G_{-\frac{1}{2}}^-\} |h, q\rangle &= (2L_0 + j_0) |h, q\rangle = (2h + q) |h, q\rangle. \end{aligned} \quad (5.26)$$

Note that for a chiral state, that is, $G_{-1/2}^+ |h, q\rangle = 0$, the left-hand side of the first equation vanishes and so we find that $h_{\text{chiral}} = +\frac{q}{2}$. Similarly, for an anti-chiral state the second equation vanishes so we can deduce that $h_{\text{anti-chiral}} = -\frac{q}{2}$.

- Next, we determine a relation between the conformal weight h and j_0 charge q for any state in the Hilbert space. To do so, we note that in a unitary theory one

necessarily has $(G_{-1/2}^+)^{\dagger} = G_{+1/2}^-$ ¹. With the help of Eq. (5.25), it then follows that

$$\langle h, q | \{G_{-\frac{1}{2}}^+, G_{+\frac{1}{2}}^-\} | h, q \rangle = \left| G_{-\frac{1}{2}}^+ | h, q \rangle \right|^2 \geq 0. \quad (5.27)$$

A similar result holds for the second line in Eq. (5.26) and so we can conclude that in a unitary theory, we have the relation $h \geq \frac{|q|}{2}$ which is saturated precisely by the chiral and anti-chiral states.

- We can even show the opposite direction of this statement. For this purpose, let us assume that a state $|h, q\rangle$ satisfies $h = \frac{q}{2}$. We then calculate

$$0 = \langle h, q | \{G_{-\frac{1}{2}}^+, G_{+\frac{1}{2}}^-\} | h, q \rangle = \left| G_{+\frac{1}{2}}^- | h, q \rangle \right|^2 + \left| G_{-\frac{1}{2}}^+ | h, q \rangle \right|^2. \quad (5.28)$$

By positivity of the norm, we see that each term on the right-hand side has to vanish implying the definition of a chiral state, i.e. $G_{-1/2}^+ |h, q\rangle = 0$. In order to show that a state with $h = \frac{q}{2}$ is also a primary, we employ the following $\mathcal{N} = 2$ commutation relation:

$$[j_n, G_{-\frac{1}{2}}^+] |h, q\rangle = G_{n-\frac{1}{2}}^+ |h, q\rangle \quad \text{for } n > 0. \quad (5.29)$$

Now, we observe that $j_n |h, q\rangle = 0$ for $n > 0$, because the conformal weight of the resulting state

$$L_0 j_n |h = \frac{q}{2}, q\rangle = \left(\frac{q}{2} - n\right) j_n |h = \frac{q}{2}, q\rangle$$

would violate the unitarity bound $h \geq \frac{|q|}{2}$. Employing Eq. (5.29) together with Eq. (5.28), we see that the first part of Eq. (5.25) is satisfied. In a similar fashion, we can use $[j_n, G_{+1/2}^-] = -G_{n+1/2}^-$ for $n > 0$ which gives the second part of the definition of a primary state. In summary, we have shown that

A state $|h, q\rangle$ is an $\mathcal{N} = 2$ chiral primary if and only if $h = \frac{q}{2}$.

Super Primary Fields

Let us now investigate what distinguishes a chiral primary field from a non-chiral primary field. Similarly as for $\mathcal{N} = 1$, in the present case the action of $G_{-1/2}^{\pm}$ combines various primary fields into a super primary field. While for $\mathcal{N} = 1$ there were

¹ This can for instance be explained by observing that the norm of a state $|G_{-r}^{\pm} |h, q\rangle|^2 = \langle h, q | (G_{+r}^{\pm})^{\dagger} G_{-r}^{\pm} |h, q\rangle$, which is a number, should not carry any residual j_0 charge.

always two components arranged into one superfield, here we have in general four components contributing to one $\mathcal{N} = 2$ super primary field which can be depicted as

$$|h, q\rangle \begin{cases} \nearrow G^+_{-\frac{1}{2}} |h, q\rangle \\ \searrow G^-_{-\frac{1}{2}} |h, q\rangle \end{cases} \begin{cases} \nearrow G^+_{-\frac{1}{2}} G^-_{-\frac{1}{2}} |h, q\rangle \\ \searrow G^-_{-\frac{1}{2}} G^+_{-\frac{1}{2}} |h, q\rangle \end{cases}$$

However, in case of a chiral field, we have $G^+_{-1/2} |h, q\rangle = 0$ so that the $\mathcal{N} = 2$ super primary consists only of two components $|h, q\rangle$ and $G^-_{-1/2} |h, q\rangle$. Such supermultiplets are called short supermultiplets and are often present in supersymmetric theories.

In general, if a super algebra allows for non-trivial central charges, there exist so-called BPS multiplets which are shorter than the average length of a supermultiplet. These BPS multiplets contain states which saturate a BPS-bound such as in Eq. (5.27). Thus, chiral primaries are a simple manifestation of this concept in $\mathcal{N} = 2$ superconformal field theories.

Chiral Ring

Let us now study the OPE of two chiral primary fields $\phi_a(z)$ and $\phi_b(w)$. Taking into account the conformal dimensions, we can infer the general form of the OPE to be

$$\phi_a(z) \phi_b(w) = \sum_c \sum_{n \geq 0} C^c_{ab} \frac{\partial^n \phi_c(w)}{(z-w)^{h_a+h_b-h_c-n}}, \tag{5.30}$$

where C^c_{ab} are some constants. For the exponent of the singular term, we employ the conservation of j_0 charges q which reads $q_a + q_b = q_c$ and leads to

$$h_a + h_b - h_c = \frac{q_a}{2} + \frac{q_b}{2} - h_c \leq \frac{q_c}{2} - \frac{|q_c|}{2} \leq 0, \tag{5.31}$$

where we used that $h \geq \frac{|q|}{2}$ for any state in the Hilbert space of a $\mathcal{N} = 2$ SCFT. From the inequality (5.31), we thus see that in the OPE (5.30) there are no singular terms. We can then define a product among the chiral primaries as follows

$$(\phi_a \cdot \phi_b)(w) = \lim_{z \rightarrow w} \phi_a(z) \phi_b(w) = \sum_c C^c_{ab} \phi_c(w). \tag{5.32}$$

Let us now remark on some properties of this product.

- There are no derivatives involved on the right-hand side of Eq. (5.32) because in the limit $z \rightarrow w$, the term $(z-w)^n$ vanishes for $n > 0$.
- In the product (5.32), only fields with $h_c = \frac{q_a+q_b}{2}$ appear since these are the only surviving terms in the limit $z \rightarrow w$. However, from our discussion at the beginning of the section, we know that these are again chiral primary fields.
- The product (5.32) defines a (finite) chiral ring among the primary fields.

Along the same lines, one finds that there is a ring of anti-chiral fields, and we note that the same structure can also be found in the anti-holomorphic sector of the $\mathcal{N} = 2$ superconformal algebra. So in total, there are four chiral rings.

We finally remark without formulas that the chiral ring gives also an example of a topological field theory. This can be seen by introducing a so-called topological twist to the $\mathcal{N} = 2$ energy–momentum tensor, which makes one of the supersymmetry generators a nilpotent BRST operator. The cohomology of this operator is precisely given by the (finite) number of chiral primaries.

Example

As an example for a chiral ring, let us consider the $\mathcal{N} = 2$ unitary models introduced on p. 178 with central charges (5.16). Recalling Eq. (5.17) and equating $h = \frac{q}{2}$, we see that

$$\text{chiral primaries in NS sector :} \quad \phi_{-l,0}^l \quad \text{for } l = 0, \dots, k ,$$

while the anti-chiral ones are determined by $h = -\frac{q}{2}$ leading to $\phi_{l,0}^l$. Employing then charge conservation, that is, $q_a + q_b = q_c$, in Eq. (5.32), we obtain the following simple form of the chiral ring:

$$\phi_{-l,0}^l \cdot \phi_{-l',0}^{l'} = \begin{cases} \phi_{-l-l',0}^{l+l'} & \text{for } l+l' \leq k , \\ 0 & \text{else .} \end{cases}$$

5.4 Spectral Flow

Spectral Flow for the Algebra

Let us now turn to the second characteristic feature of $\mathcal{N} = 2$ superconformal field theories which is the so-called spectral flow. In particular, there exists a continuous class of automorphisms of the $\mathcal{N} = 2$ super Virasoro algebra, or in other words, there is a continuous deformation of the $\mathcal{N} = 2$ generators such that the deformed operators still satisfy the algebra (5.14). Concretely, this deformation reads

$$\begin{aligned} L_n &\mapsto L'_n = L_n + \eta j_n + \frac{\eta^2}{6} c \delta_{n,0} , \\ j_n &\mapsto j'_n = j_n + \frac{c}{3} \eta \delta_{n,0} , \\ G_r^\pm &\mapsto G_r^{\pm'} = G_{r \pm \eta}^\pm , \end{aligned} \tag{5.33}$$

where η is a continuous parameter. We will not check thoroughly that the deformed generators L'_m , j'_n and $G_r^{\pm'}$ satisfy the algebra (5.14) but restrict ourselves to the anti-commutator of two $G^\pm(z)$ modes. For those we calculate

$$\begin{aligned}
\{G_r^{+'}, G_s^{-'}\} &= \{G_{r+\eta}^+, G_{s-\eta}^-\} \\
&= 2L_{r+s} + (r-s+2\eta)j_{r+s} + \frac{c}{3}\left((r+\eta)^2 - \frac{1}{4}\right)\delta_{r+s,0} \\
&= 2\left(L_{r+s} + \eta j_{r+s} + \frac{\eta^2}{6}c\delta_{r+s,0}\right) + (r-s)\left(j_{r+s} + \frac{c}{3}\eta\delta_{r+s,0}\right) \\
&\quad + \frac{c}{3}\left(r^2 - \frac{1}{4}\right)\delta_{r+s,0} \\
&= 2L'_{r+s} + (r-s)j'_{r+s} + \frac{c}{3}\left(r^2 - \frac{1}{4}\right)\delta_{r+s,0},
\end{aligned}$$

which indeed shows that this relation is invariant under the deformation (5.33).

From Eq. (5.33) we observe that via the spectral flow, the moding of the generators G_r^\pm is changed. In particular, for $\eta \in \mathbb{Z} + \frac{1}{2}$ the flow interpolates between the Neveu–Schwarz sector with half-integer modes and the Ramond sector with integer moding. That is, there exists a one-to-one mapping between both sectors.

Spectral Flow for Representations

After having considered the invariance of the $\mathcal{N} = 2$ superconformal algebra under the spectral flow, we will now investigate the behaviour of the corresponding representations. To do so, let us start by introducing some notation for the spectral flow acting on the operators L_m and j_m as well as on states $|\phi\rangle$. Similar to Quantum Mechanics, the spectral flow can be described by a unitary operator U_η in the following way:

$$L'_m = U_\eta L_m U_\eta^\dagger, \quad j'_m = U_\eta j_m U_\eta^\dagger, \quad |\phi_\eta\rangle = U_\eta |\phi\rangle.$$

Note that for $\eta = 0$, the operator $U_{\eta=0}$ is the identity operator. It is now easy to determine the conformal weight and j_0 charge of $|\phi_\eta\rangle$ with respect to the transformed operators. For the conformal weight we calculate

$$L'_0 |\phi_\eta\rangle = U_\eta L_0 U_\eta^\dagger U_\eta |\phi\rangle = U_\eta h |\phi\rangle = h |\phi_\eta\rangle,$$

and for the j_0 charge we find similarly

$$j'_0 |\phi_\eta\rangle = U_\eta j_0 U_\eta^\dagger U_\eta |\phi\rangle = U_\eta q |\phi\rangle = q |\phi_\eta\rangle. \quad (5.34)$$

This is of course what we expect, namely that the conformal weight h and j_0 charge q of the transformed state measured by the transformed operators do not change compared to the original theory.

However, we are actually interested in how h and q of the transformed state $|\phi_\eta\rangle$ change with respect to the original theory. To determine this, we note that the spectral flow has no effect on the moding of the generators L_m and j_m and so we can write

$$L_0 |\phi_\eta\rangle = h_\eta |\phi_\eta\rangle, \quad j_0 |\phi_\eta\rangle = q_\eta |\phi_\eta\rangle.$$

Using then Eq. (5.33), we find

$$L'_0 |\phi_\eta\rangle = \left(L_0 + \eta j_0 + \frac{\eta^2}{6} c \right) |\phi_\eta\rangle = \left(h_\eta + \eta q_\eta + \frac{\eta^2}{6} c \right) |\phi_\eta\rangle,$$

and

$$j'_0 |\phi_\eta\rangle = \left(j_0 + \frac{c}{3} \eta \right) |\phi_\eta\rangle = \left(q_\eta + \frac{c}{3} \eta \right) |\phi_\eta\rangle.$$

Combining these two equations with Eq. (5.34), we can express the conformal weight and j_0 charge of the transformed state with respect to the original operators in the following way:

$$h_\eta = h - \eta q + \frac{\eta^2}{6} c, \quad q_\eta = q - \frac{c}{3} \eta. \quad (5.35)$$

Transformation of Chiral Primaries

As we have mentioned above, for operators the spectral flow with $\eta \in \mathbb{Z} + \frac{1}{2}$ interpolates between the Neveu–Schwarz and Ramond sectors. Let us now investigate this point for chiral primaries. In particular, using Eq. (5.35) with $\eta = \frac{1}{2}$ and employing $h = \frac{q}{2}$ for a chiral primary, we obtain

$$\left| h_0 = \frac{q_0}{2}, q_0 \right\rangle_{\text{NS}} \xrightarrow{\eta=\frac{1}{2}} \left| h_{\frac{1}{2}} = \frac{c}{24}, q_{\frac{1}{2}} = q_0 - \frac{c}{6} \right\rangle_{\text{R}}, \quad (5.36)$$

where the subscripts label the Neveu–Schwarz and Ramond sectors, respectively. The conformal weight of the state in the Ramond sector is $h = \frac{c}{24}$ which is independent of the j_0 charge q . Therefore, this state is degenerate since there are as many different j_0 charges as there are chiral primaries in the NS sector. Next, we show that the state in the Ramond sector is actually a ground state. To do so, we recall $(G_0^+)^\dagger = G_0^-$ for a unitary theory and compute using the algebra (5.14)

$$\begin{aligned} 0 &\leq \left| G_0^+ |h, q\rangle_{\text{R}} \right|^2 = {}_{\text{R}} \langle h, q | G_0^- G_0^+ |h, q\rangle_{\text{R}} \\ &= {}_{\text{R}} \langle h, q | \{ G_0^- G_0^+ \} |h, q\rangle_{\text{R}} - {}_{\text{R}} \langle h, q | G_0^+ G_0^- |h, q\rangle_{\text{R}} \\ &= 2h - \frac{c}{12} - \left| G_0^- |h, q\rangle_{\text{R}} \right|^2. \end{aligned}$$

Since $G_0^- |h, q\rangle_{\text{R}}$ can be vanishing, the lowest possible value for the conformal weight of a state is $h = \frac{c}{24}$, which is satisfied by the state in the Ramond sector in Eq. (5.36). Thus, it is a ground state. We finally note that the field which maps

the NS vacuum with $h = q = 0$ to the Ramond sector is called the spectral flow operator and has conformal weight $h = \frac{c}{24}$ and charge $q = -\frac{c}{6}$.

Let us perform a further transformation with $\eta = \frac{1}{2}$ mapping now the Ramond sector again to the Neveu–Schwarz sector. Employing Eq. (5.35) with $\eta = 1$, we find

$$\left| h_0 = \frac{q_0}{2}, q_0 \right\rangle_{\text{NS}} \xrightarrow{\eta=1} \left| h_1 = -\frac{q_1}{2}, q_1 = q_0 - \frac{c}{3} \right\rangle_{\text{NS}},$$

which is an anti-chiral primary in the NS sector. Therefore, the spectral flow with $\eta = 1$ maps chiral states in the NS sector to anti-chiral states in the same sector.

Example

As an example for the spectral flow, we consider again the $\mathcal{N} = 2$ unitary series described on p. 178. As we have seen previously, the chiral primaries in the NS sector are characterised by

$$\phi^l_{-l,0} \quad \text{with} \quad h = \frac{q}{2} = \frac{l}{2(k+2)}.$$

Applying then the spectral flow with $\eta = \frac{1}{2}$ to the Ramond sector, the highest weight representations above are mapped to

$$\phi^l_{-l-1,-1} \quad \text{with} \quad h = \frac{c}{24}, \quad q = \frac{2l-k}{2(k+2)}.$$

The spectral flow operator mapping the NS vacuum to the Ramond sector is characterised by $(h, q) = (\frac{c}{24}, -\frac{c}{6})$ which gives $\phi^0_{-1,-1}$. In summary, for the $\mathcal{N} = 2$ minimal models, we identified the following states and operators:

chiral primaries in the NS sector	$\phi^l_{-l,0}$,
Ramond sector ground states	$\phi^l_{-l-1,-1}$,
spectral flow operator	$\phi^0_{-1,-1}$.

5.5 Coset Construction for the $\mathcal{N} = 2$ Unitary Series

Coset Construction

In Sect. 4.5, we have studied the characters and corresponding S -matrices for the unitary models of the Virasoro algebra via a coset construction. For the unitary models of the $\mathcal{N} = 1$ super Virasoro algebra, we only stated the coset construction in Eq. (5.10) since the $\mathcal{N} = 1$ theories will not be important in the following.

However, the $\mathcal{N} = 2$ unitary series will be of more interest to us. Let us therefore consider the following coset:

$$\frac{\widehat{\mathfrak{su}}(2)_k \times \widehat{\mathfrak{u}}(1)_2}{\widehat{\mathfrak{u}}(1)_{k+2}}. \quad (5.37)$$

Referring to Sect. 3.6, the central charge of this CFT is calculated as

$$c = c_{\widehat{\mathfrak{su}}(2)_k} + c_{\widehat{\mathfrak{u}}(1)_2} - c_{\widehat{\mathfrak{u}}(1)_{k+2}} = \frac{3k}{k+2},$$

where we utilised that the central charge for any $\widehat{\mathfrak{u}}(1)_k$ Kač–Moody algebra is one, as well as Eq. (3.7) giving the central charge of $\widehat{\mathfrak{su}}(2)_k$. By comparing with Eq. (5.16), we see that the coset (5.37) has the same series of central charges as the unitary series of the $\mathcal{N} = 2$ Virasoro algebra.

Next, the decomposition of representations of the coset (5.37) is achieved via the branching rules which in the present case read

$$(\lambda_{\widehat{\mathfrak{su}}(2)_k}) \otimes (\lambda_{\widehat{\mathfrak{u}}(1)_2}) = \bigoplus_{\lambda_{\widehat{\mathfrak{u}}(1)_{k+2}}} (\lambda_{\widehat{\mathfrak{u}}(1)_{k+2}}) \otimes (\lambda_{\widehat{\mathfrak{su}}(2)_k \times \widehat{\mathfrak{u}}(1)_2 / \widehat{\mathfrak{u}}(1)_{k+2}}). \quad (5.38)$$

Similarly as in Sects. 4.5 and 4.6, we can now derive an expression for the corresponding characters in the following way:

$$\chi_l^{\widehat{\mathfrak{su}}(2)_k}(\tau) \chi_s^{\widehat{\mathfrak{u}}(1)_2}(\tau) = \sum_{m=-k-1}^{k+2} \chi_m^{\widehat{\mathfrak{u}}(1)_{k+2}}(\tau) \chi_{m,s}^l(\tau), \quad (5.39)$$

where $\chi_{m,s}^l$ are the branching functions we are interested in. The conformal dimension of the character can be calculated using the decomposition (5.38) and the formulas for the weights of $\widehat{\mathfrak{su}}(2)_k$ and $\widehat{\mathfrak{u}}(1)_k$ characters. Again, consistent with the unitary $\mathcal{N} = 2$ series, the conformal dimensions read

$$h_{m,s}^l = h_l^{\widehat{\mathfrak{su}}(2)_k} + h_s^{\widehat{\mathfrak{u}}(1)_2} - h_m^{\widehat{\mathfrak{u}}(1)_{k+2}} = \frac{l(l+2)}{4(k+2)} + \frac{s^2}{4 \cdot 2} - \frac{m^2}{4(k+2)}.$$

This result gives us sufficient confidence that the coset (5.37) indeed gives rise to the unitary series of the $\mathcal{N} = 2$ super Virasoro algebra. Without presenting the details, let us mention that one can also explicitly show that the coset contains the generators of the $\mathcal{N} = 2$ super Virasoro algebra.

Characters

For the actual computation of the $\mathcal{N} = 2$ characters $\chi_{m,s}^l$, we recall our discussion around Eq. (4.68) and express the $\widehat{\mathfrak{su}}(2)_k$ characters in terms of the string functions $C_{l,m}^{(k)}$ in the following way:

$$\chi_l^{\widehat{\mathfrak{su}}(2)_k} = \sum_{\substack{m=-k+1 \\ l+m=0 \pmod{2}}}^k C_{l,m}^{(k)}(\tau) \Theta_{m,k}(\tau) .$$

We can then use this formula together with the explicit form of the $\widehat{\mathfrak{u}}(1)_k$ characters in the decomposition (5.39) leading to

$$\sum_{\substack{m=-k+1 \\ l+m=0 \pmod{2}}}^k C_{l,m}^{(k)}(\tau) \Theta_{m,k}(\tau) \frac{\Theta_{s,2}(\tau)}{\eta(\tau)} = \sum_{m=-k-1}^{k+2} \frac{\Theta_{m,k+2}(\tau)}{\eta(\tau)} \chi_{m,s}^l(\tau) . \quad (5.40)$$

In order to proceed, we note without proof the following identity among the Θ -functions

$$\Theta_{l,k} \Theta_{l',k'} = \sum_{j=1}^{k+k'} \Theta_{2k'j+l+l', k+k'} \Theta_{2kk'j-lk'+l'k, kk'(k+k')} ,$$

where for ease of notation we suppressed the τ dependence. Applying this relation to expression (5.40), we find

$$\sum_{\substack{m=-k+1 \\ l+m=0 \pmod{2}}}^k \sum_{j=1}^{k+2} C_{l,m}^{(k)} \Theta_{4j+m+s,k+2} \Theta_{4jk-2m+ks,2k(k+2)} = \sum_{m=-k-1}^{k+2} \Theta_{m,k+2} \chi_{m,s}^l .$$

Finally, on the left-hand side of this formula, we extract the terms multiplying $\Theta_{m,k+2}(\tau)$ giving us the following explicit form of $\chi_{m,s}^l$:

$$\chi_{m,s}^l(\tau) = \sum_{j=1}^{k+2} C_{l,m-4j-s}^{(k)}(\tau) \Theta_{-2m+(4j+s)(k+2), 2k(k+2)} ,$$

with the restriction that $l + m + s \in 2\mathbb{Z}$. These are the characters for the unitary series of the $\mathcal{N} = 2$ super Virasoro algebra.

Modular S-Matrix

From the decomposition (5.39), we can also read off the modular S -matrix for the $\mathcal{N} = 2$ characters $\chi_{m,s}^l(\tau)$. In particular, we find

$$S_{l,l'}^{\widehat{\mathfrak{su}}(2)_k} S_{s,s'}^{\widehat{\mathfrak{u}}(1)_2} = S_{m,m'}^{\widehat{\mathfrak{u}}(1)_{k+2}} S_{(lms)(l'm's')}^{\mathcal{N}=2} .$$

Employing then the explicit expression of the $\widehat{\mathfrak{su}}(2)_k$ and $\widehat{\mathfrak{u}}(1)_k$ S -matrices, the modular S -matrix for $\chi_{m,s}^l(\tau)$ is obtained as

$$\begin{aligned} S_{(lms)(l'm's')}^{\mathcal{N}=2} &= (S^{\widehat{\mathfrak{u}}(1)_{k+2}})^{-1}_{m,m'} S_{l,l'}^{\widehat{\mathfrak{su}}(2)_k} S_{s,s'}^{\widehat{\mathfrak{u}}(1)_2} \\ &= \frac{1}{\sqrt{2(k+2)}} e^{+\pi i \frac{mm'}{k+2}} \sqrt{\frac{2}{k+2}} \sin\left(\frac{\pi}{k+2}(l+1)(l'+1)\right) \frac{1}{2} e^{-\pi i \frac{ss'}{2}} \\ &= \frac{1}{2k+4} \sin\left(\frac{\pi}{k+2}(l+1)(l'+1)\right) e^{-\pi i \left(\frac{ss'}{2} - \frac{mm'}{k+2}\right)}. \end{aligned}$$

Similarly as in Sect. 4.5, a set of modular invariant partition functions automatically follows by combining modular invariants of each individual theory. Thus, the matrix M in $\mathcal{Z}(\tau, \bar{\tau}) = \chi^T(\tau) M \bar{\chi}(\bar{\tau})$ can be written as

$$M_{(lms)(l'm's')}^{\mathcal{N}=2} = M_{ll'}^{\widehat{\mathfrak{su}}(2)_k} M_{mm'}^{\widehat{\mathfrak{u}}(1)_{k+2}} M_{ss'}^{\widehat{\mathfrak{u}}(1)_2},$$

with $M^{\widehat{\mathfrak{su}}(2)_k}$ being one matrix out of the A-D-E classification for $\widehat{\mathfrak{su}}(2)_k$ modular invariant partition functions while the other matrices corresponds to $\widehat{\mathfrak{u}}(1)_k$.

Fusion Rules

From the modular S -matrix, we finally determine the fusion coefficients via the Verlinde formula. Combining the results of each individual theory, we find

$$[\phi_{m_1, s_1}^{l_1}] \times [\phi_{m_2, s_2}^{l_2}] = \sum_{l_3, m_3, s_3} N_{l_1 l_2}^{l_3} \delta_{m_1+m_2-m_3, 0}^{(k+2)} \delta_{s_1+s_2-s_3, 0}^{(2)} [\phi_{m_3, s_3}^{l_3}], \quad (5.41)$$

where $N_{l_1 l_2}^{l_3}$ are the $\widehat{\mathfrak{su}}(2)_k$ fusion coefficients (4.60). By comparing with the definition of a simple current from Sect. 4.7, we see that all fields $\phi_{m,s}^0$ with $m+s \in 2\mathbb{Z}$ are in fact simple currents. In particular, the fields

$$\phi_{-1, -1}^0 \quad \text{and} \quad \phi_{0, 2}^0 \quad \text{are simple currents.} \quad (5.42)$$

5.6 Gepner Models

In the previous sections and chapters of these lecture notes, we have studied and collected all necessary prerequisites for presenting a beautiful and powerful application of conformal field theory techniques to string theory. In particular, in the following we will consider string theory compactifications from ten-dimensional to four-dimensional space–time on so-called Calabi–Yau manifolds which are known to preserve some supersymmetry in four dimensions. It is quite remarkable that the two-dimensional non-linear sigma model governing the motion of a string moving on such highly curved manifolds can be solved exactly, at least for special points

in moduli space. The methods to study such backgrounds usually do not involve the non-linear sigma model Lagrangian, but utilise advanced conformal field theory techniques to define interacting SCFTs. The latter are then shown to have the features expected from Calabi–Yau compactifications. These models have been proposed by D. Gepner in 1988 and have been generalised and investigated in many directions since then.

Because in these lecture notes on CFT we could not introduce all the string theory material ideally needed, we will try to take just the minimal input from string theory and employ mostly the CFT techniques developed so far.

Compactification

String theory has the remarkable feature to require a specific central charge for its CFT in order to be consistent. As we just mentioned, it is beyond the scope of these lecture notes to derive this fact from string theory. Instead, we only state that for the bosonic string this result is very much related to the (b, c) ghost system discussed in Sect. 2.9.3. In particular, these reparametrisation ghosts arise in the BRST quantisation of the string action whose CFT, as computed, has central charge $c = -26$. The cancellation of the conformal anomaly then requires the presence of 26 free bosons each with central charge $c = 1$. For the superstring, in addition there appear superconformal ghosts with total central charge $c = 11$ leading to $c_{\text{ghost}} = -26 + 11 = -15$, so that one needs 10 free boson–fermion pairs with $c = \frac{3}{2}$ to cancel the conformal anomaly.

However, instead of this so-called covariant quantisation involving ghosts, one can employ light-cone coordinates which remove two bosons (and fermions) from the quantisation process. For bosonic string theory, the central charges of the left- and right-moving sector, i.e. of the holomorphic and anti-holomorphic sector, then have to be $(c_L, c_R) = (24, 24)$. For superstring theory with $\mathcal{N} = (1, 1)$ superconformal symmetry² on the world-sheet, one finds $(c_L, c_R) = (12, 12)$ while for the heterotic string, a mixture between the bosonic and supersymmetric case, one obtains $(c_L, c_R) = (24, 12)$.

The starting point for the Gepner construction is the bosonic string in light-cone gauge with central charges $(c_L, c_R) = (24, 24)$ consisting of the following building blocks.

- We assume a four-dimensional flat space–time with coordinates X^μ where $\mu = 0, \dots, 3$. Two of these, say X^0 and X^1 , are arranged into light-cone coordinates $X^+ = \frac{1}{\sqrt{2}}(X^0 + X^1)$ and $X^- = \frac{1}{\sqrt{2}}(X^0 - X^1)$ which can be gauged away. We are thus left with X^2 and X^3 to which we associate two copies of the free boson CFT with central charge $c = 1$.

² The notation $\mathcal{N} = (1, 1)$ means that there is $\mathcal{N} = 1$ superconformal symmetry in the holomorphic and in the anti-holomorphic sector.

- In addition to the four-dimensional part, for reasons that will become clear later, we consider an $\mathcal{N} = 2$ SCFT in the holomorphic and anti-holomorphic sector with central charges $(c_L, c_R) = (9, 9)$ describing six compact coordinates together with the fermionic partners.
- Finally, the residual central charges are occupied by an $(\widehat{\mathfrak{e}}_8)_1 \times \widehat{\mathfrak{so}}(10)_1$ Kač–Moody algebra with $(c_L, c_R) = (13, 13)$. This algebra is realised by 13 free bosons compactified on the root lattice of $\mathfrak{e}_8 \times \mathfrak{so}(10)$.

In summary, the construction of the bosonic string theory is achieved in the following way:

$$\begin{array}{ll}
 \text{two copies of the free boson CFT given by } X^2 \text{ and } X^3 & : (c_L, c_R) = (2, 2) \\
 \text{an } \mathcal{N} = (2, 2) \text{ SCFT} & : (c_L, c_R) = (9, 9) \\
 \text{an } (\widehat{\mathfrak{e}}_8)_1 \times \widehat{\mathfrak{so}}(10)_1 \text{ Kač–Moody algebra} & : (c_L, c_R) = (13, 13)
 \end{array}$$

The $(\widehat{\mathfrak{e}}_8)_1 \times \widehat{\mathfrak{so}}(10)_1$ Kač–Moody Algebra

Let us now consider more closely the CFT determined by the Kač–Moody algebra $(\widehat{\mathfrak{e}}_8)_1 \times \widehat{\mathfrak{so}}(10)_1$. From Sect. 3.4, we recall that $\widehat{\mathfrak{so}}(10)_1$ can be realised by 10 free fermions transforming in the vector representation of $SO(10)$. Completely analogously to the case of one free fermion discussed in Sect. 4.2, the characters here can be expressed in terms of Jacobi ϑ -functions. As for $\widehat{\mathfrak{so}}(2)_1$ in Eq. (5.22), there are four irreducible highest weight representations for $\widehat{\mathfrak{so}}(10)_1$ with characters

$$\begin{aligned}
 \chi_O^{(0,0)} &= \frac{1}{2} \left(\left(\frac{\vartheta_3}{\eta} \right)^5 + \left(\frac{\vartheta_4}{\eta} \right)^5 \right), & \chi_S^{(\frac{5}{8}, \frac{1}{2})} &= \frac{1}{2} \left(\left(\frac{\vartheta_2}{\eta} \right)^5 + i \left(\frac{\vartheta_1}{\eta} \right)^5 \right), \\
 \chi_V^{(\frac{1}{2}, 1)} &= \frac{1}{2} \left(\left(\frac{\vartheta_3}{\eta} \right)^5 - \left(\frac{\vartheta_4}{\eta} \right)^5 \right), & \chi_C^{(\frac{5}{8}, -\frac{1}{2})} &= \frac{1}{2} \left(\left(\frac{\vartheta_2}{\eta} \right)^5 - i \left(\frac{\vartheta_1}{\eta} \right)^5 \right).
 \end{aligned} \tag{5.43}$$

Note that the superscripts on the characters indicate the conformal weight and the charge with respect to the current

$$j_{\widehat{\mathfrak{so}}(10)_1}(z) = \sum_{\alpha=1}^5 N(\Psi_\alpha \bar{\Psi}_\alpha)(z),$$

where the five complex fermions Ψ_α realise the $\widehat{\mathfrak{so}}(10)_1$ current algebra. From the modular properties of the η - and ϑ -functions summarised for instance at the end of Sect. 4.2.4, we can then deduce the modular S -matrix for $\widehat{\mathfrak{so}}(10)_1$ to be of the form

$$S^{\widehat{\mathfrak{so}}(10)_1} = \frac{1}{2} \begin{pmatrix} 1 & 1 & 1 & 1 \\ 1 & 1 & -1 & -1 \\ 1 & -1 & -i & +i \\ 1 & -1 & +i & -i \end{pmatrix}. \tag{5.44}$$

This matrix is again understood as acting on the vector $\chi = (\chi_O, \chi_V, \chi_S, \chi_C)^T$ which we will abbreviate as (O, V, S, C) in the following. From the modular S -matrix, we can determine the fusion rules of $\widehat{\mathfrak{so}}(10)_1$ via the Verlinde formula given in Eq. (4.55). Explicitly, they read

$$\begin{aligned} [V] \times [V] &= [O], & [S] \times [S] &= [V], & [C] \times [C] &= [V], \\ [S] \times [C] &= [O], & [S] \times [V] &= [C], & [C] \times [V] &= [S], \end{aligned} \tag{5.45}$$

where O is the vacuum representation and thus the identity.

The Bosonic String Map

Let us now observe the interesting fact that the S -matrix (5.44) for $\widehat{\mathfrak{so}}(10)_1$ is the same as for $\widehat{\mathfrak{so}}(2)_1$ given in Eq. (5.23). Furthermore, the difference between the central charges of $(\widehat{\mathfrak{e}}_8)_1 \times \widehat{\mathfrak{so}}(10)_1$ and $\widehat{\mathfrak{so}}(2)_1$ is determined to be

$$c_{(\widehat{\mathfrak{e}}_8)_1 \times \widehat{\mathfrak{so}}(10)_1} - c_{\widehat{\mathfrak{so}}(2)_1} = 13 - 1 = 12.$$

Therefore, one might hope that replacing the $(\widehat{\mathfrak{e}}_8)_1 \times \widehat{\mathfrak{so}}(10)_1$ algebra by $\widehat{\mathfrak{so}}(2)_1$ could map the partition function of the bosonic string with $(c_L, c_r) = (24, 24)$ to a partition function of the superstring with $(c_L, c_r) = (12, 12)$. Indeed, $\widehat{\mathfrak{so}}(2)_1$ is just the Kač–Moody algebra formed by the two free fermions, which under such a mapping could become the superpartners of the two free bosons X^3 and X^4 in four dimensions. Schematically, this reads

$$\begin{aligned} (2 \times (X) \text{ CFT})_{(2,2)} \times ((\widehat{\mathfrak{e}}_8)_1 \times \widehat{\mathfrak{so}}(10)_1)_{(13,13)} \times (\mathcal{N} = (2, 2) \text{ SCFT})_{(9,9)} \\ \longrightarrow (2 \times (X) \text{ CFT})_{(2,2)} \times (\widehat{\mathfrak{so}}(2)_1)_{(1,1)} \times (\mathcal{N} = (2, 2) \text{ SCFT})_{(9,9)} \\ = (2 \times (X, \psi) \text{ SCFT})_{(3,3)} \times (\mathcal{N} = (2, 2) \text{ SCFT})_{(9,9)}, \end{aligned}$$

where the subscripts indicate the central charges of the CFTs. Note finally that the singlet O and the vector representation V of $\widehat{\mathfrak{so}}(2)_1$ lead to space–time bosons and the spinor and anti-spinor ones S, C to space–time fermions.

$$\begin{aligned} O, V \text{ representations} &\Leftrightarrow \text{Neveu–Schwarz sector} &\Leftrightarrow \text{space–time bosons} \\ S, C \text{ representations} &\Leftrightarrow \text{Ramond sector} &\Leftrightarrow \text{space–time fermions} \end{aligned}$$

However, for the spinor representations the conformal weights in the $(\widehat{\mathfrak{e}}_8)_1 \times \widehat{\mathfrak{so}}(10)_1$ theory and in the $\widehat{\mathfrak{so}}(2)_1$ theory are not equal, i.e.

$$h(S^{\widehat{\mathfrak{so}}(10)_1}) - h(S^{\widehat{\mathfrak{so}}(2)_1}) = \frac{1}{2} .$$

Therefore, in a modular invariant partition function, we cannot simply replace the $\widehat{\mathfrak{so}}(10)_1$ characters $(O, V, S, C)_{\widehat{\mathfrak{so}}(10)_1}$ by $(O, V, S, C)_{\widehat{\mathfrak{so}}(2)_1}$, as this would violate the level-matching condition whenever say a left-moving (O, V) character is combined with a right-moving (S, C) character and vice versa. But, from Eq. (5.44) one can see that there exists also the possibility to replace

$$(O, V, S, C)_{\widehat{\mathfrak{so}}(10)_1} \longrightarrow (V, O, -C, -S)_{\widehat{\mathfrak{so}}(2)_1} ,$$

which indeed maps a modular invariant $\widehat{\mathfrak{so}}(10)_1$ partition function to a $\widehat{\mathfrak{so}}(2)_1$ MIPF without being in conflict with the level-matching constraint. This is the so-called bosonic string map. Noting finally that $(\widehat{\mathfrak{e}}_8)_1$ has only the singlet representation (1) with conformal weight $h = 0$ which is invariant under modular S -transformations, we can replace

$$(1)_{(\widehat{\mathfrak{e}}_8)_1} \otimes (O, V, S, C)_{\widehat{\mathfrak{so}}(10)_1} \longrightarrow (V, O, -C, -S)_{\widehat{\mathfrak{so}}(2)_1} . \quad (5.46)$$

As we will see more concretely later, this transforms a partition function of the bosonic string to a supersymmetric one of either the heterotic string, when applying the mapping only to the right-moving sector, or to the Type II string when applying it both to the left- and right-moving sectors. We therefore have the possibility to obtain partition functions of supersymmetric string theories from bosonic ones. Together with the simple current construction, we thus have availability of a very powerful technique to derive new MIPFs from existing ones.

Gepner's Construction

Let us now turn to the say holomorphic $\mathcal{N} = 2$ SCFT with central charge $c_L = 9$. Doron Gepner proposed to choose for this SCFT the tensor product of unitary $\mathcal{N} = 2$ Virasoro models with $0 < c < 3$ in the following way:

$$(\mathcal{N} = 2)_{c=9} = \bigotimes_{i=1}^r (\mathcal{N} = 2)_{c_i}^{\text{Vir}} \quad \text{with} \quad \sum_{i=1}^r c_i = \sum_{i=1}^r \frac{3k_i}{k_i + 2} = 9 .$$

Because the k_i are integers, it turns out that there are only 168 combinations which have total central charge $c = 9$. For example, one can choose $r = 5$ factors with $k_i = 3$ giving $c_i = \frac{9}{5}$ and thus in total $c = 9$. Let us mention that an explicit classification shows that most cases have $r = 4$ or $r = 5$ with a few exceptions of $r = 6, 9$.

Except the two free bosons X^2 and X^3 , the CFT in the holomorphic sector of the bosonic string (before the bosonic string map) therefore has the following tensor product structure:

$$\bigotimes_{i=1}^r (\mathcal{N} = 2)_{c_i}^{\text{Vir}} \otimes \widehat{\mathfrak{so}}(10)_1 \otimes (\widehat{\mathfrak{e}}_8)_1 . \tag{5.47}$$

The highest weight representations of this product CFT are again tensor products of the individual HWRs which we will denote as

$$\bigotimes_{i=1}^r (l_i, m_i, s_i) \otimes (s_0) \otimes (1) , \tag{5.48}$$

where s_0 labels O, V, C, S while the singlet representation of $(\widehat{\mathfrak{e}}_8)_1$ is usually omitted. The energy–momentum tensor and $U(1)$ current of the entire CFT is given by

$$T(z) = \sum_{i=1}^r T_i(z) + T_{\widehat{\mathfrak{so}}(10)_1 \otimes (\widehat{\mathfrak{e}}_8)_1}(z) ,$$

$$j(z) = \sum_{i=1}^r j_i(z) + \sum_{\alpha=1}^5 N(\Psi_\alpha \bar{\Psi}_\alpha)(z) ,$$

where T_i and j_i are the energy–momentum tensor and the $U(1)$ current for each $\mathcal{N} = 2$ tensor factor in Eq. (5.47), respectively, and the five complex fermions Ψ_α realise the $\widehat{\mathfrak{so}}(10)_1$ current algebra.

Simple Current Construction I

For the theory given in Eq. (5.47), one can construct the trivial diagonal modular invariant partition function. However, after applying the bosonic string map (5.46) this partition function will not correspond to a space–time supersymmetric string compactification. In particular, there are not the same number of states in the Neveu–Schwarz as in the Ramond sector which leads to an unequal number of bosons and fermions in the four-dimensional space–time described by X^0, \dots, X^3 . What is needed to ensure space–time supersymmetry is a Gliozzi–Scherk–Olive (GSO) projection, which can be implemented by a simple current construction.

In addition, so far the tensor product theory (5.47) is lacking a clear definition of the Neveu–Schwarz and Ramond sectors since there is no restriction on how to combine the minimal $\mathcal{N} = 2$ models with the $\widehat{\mathfrak{so}}(10)_1$ theory. Let us therefore consider the set of simple currents given by

$$J_i = (0, 0, 0) \dots \underbrace{(0, 0, 2)}_{i\text{th pos.}} \dots (0, 0, 0) (V) , \quad i = 1, \dots, r , \tag{5.49}$$

where the notation is as in Eq. (5.48). The conformal weight of the J_i is the sum of each tensor factor. Therefore, recalling from Eq. (5.43) that V has conformal weight $h_V = \frac{1}{2}$ and computing from Eq. (5.17) $h_{0,0}^0 = 0$ and $h_{0,2}^0 = \frac{3}{2}$, we find

$$h_{J_i} = (r - 1) \cdot h_{0,0}^0 + h_{0,2}^0 + h_V = 2 .$$

We furthermore recall from Eq. (5.42) that for unitary $\mathcal{N} = 2$ models, representations with $(l, m, s) = (0, m, s)$ and $m + s \in 2\mathbb{Z}$ are simple currents. Therefore, all the J_i in Eq. (5.49) are orbit simple currents.

Let us next exemplify that the simple current construction with the currents (5.49) indeed has the effect we are interested in, namely that only the combinations $(\text{NS})_{\text{Vir}} \otimes (\text{NS})_{\widehat{\mathfrak{so}}(10)_1}$ and $(\text{R})_{\text{Vir}} \otimes (\text{R})_{\widehat{\mathfrak{so}}(10)_1}$ survive the projection. Here the two specifications of the sector refer to the product theory of minimal $\mathcal{N} = 2$ supersymmetric models and to the factor of the $\widehat{\mathfrak{so}}(10)_1$ theory. We start by computing from Eq. (5.41) the following fusion rules for the unitary $\mathcal{N} = 2$ models:

$$[\phi_{0,0}^0] \times [\phi_{m,s}^l] = [\phi_{m,s}^l] , \quad [\phi_{0,2}^0] \times [\phi_{m,s}^l] = [\phi_{m,s+2}^l] ,$$

where apparently the latter maps an NS state with conformal weight h to another NS state with $h' = h + \frac{1}{2}$ as well as a Ramond state to another Ramond state with $h' = h + \mathbb{Z}$. Recalling then the fusion rules (5.45) for $\widehat{\mathfrak{so}}(10)_1$, we compute for instance

$$[J_i] \times \left[(\text{NS})_{\text{Vir}} \otimes (O, V)_{\widehat{\mathfrak{so}}(10)_1} \right] = \left[(\text{NS}')_{\text{Vir}} \otimes (V, O)_{\widehat{\mathfrak{so}}(10)_1} \right] ,$$

where NS denotes some state in the Neveu–Schwarz sector of the minimal model theory and (O, V) stands for the O or V representation of the $\widehat{\mathfrak{so}}(10)_1$ Kač–Moody algebra. The monodromy charge (4.72) for the simple current construction of this state then reads

$$\begin{aligned} \mathcal{Q}(\text{state}) &= h(J_i) + h(\text{state}) - h(J_i \times \text{state}) \pmod{1} \\ &= 2 + \left(h_{\text{Vir}} + (0, \frac{1}{2})_{\widehat{\mathfrak{so}}(10)_1} \right) - \left(h_{\text{Vir}} + \frac{1}{2} + (\frac{1}{2}, 0)_{\widehat{\mathfrak{so}}(10)_1} \right) \pmod{1} \\ &= 0 , \end{aligned}$$

where “state” refers to $(\text{NS})_{\text{Vir}} \otimes (O, V)_{\widehat{\mathfrak{so}}(10)_1}$ in the theory determined by Eq. (5.47). Since the monodromy charge is always zero, such states will survive the simple current projection. But let us consider also the action of the simple current (5.49) on a different state

$$[J_i] \times \left[(\text{R})_{\text{Vir}} \otimes (O, V)_{\widehat{\mathfrak{so}}(10)_1} \right] = \left[(\text{R}')_{\text{Vir}} \otimes (V, O)_{\widehat{\mathfrak{so}}(10)_1} \right] ,$$

for which we calculate the monodromy charge as follows

$$\begin{aligned}
Q(\text{state}) &= h(J_i) + h(\text{state}) - h(J_i \times \text{state}) \\
&= 2 + \left(h_{\text{vir}} + \left(0, \frac{1}{2}\right)_{\widehat{\mathfrak{so}}(10)_1} \right) - \left(h_{\text{vir}} + \mathbb{Z} + \left(\frac{1}{2}, 0\right)_{\widehat{\mathfrak{so}}(10)_1} \right) \pmod{1} \\
&= \frac{1}{2}.
\end{aligned}$$

Since the monodromy charge does not vanish, such a state is projected out by the simple current construction.

In summary, we have illustrated the general result that the monodromy charges with respect to the simple currents (5.49) satisfy

$$\begin{aligned}
Q\left((\text{NS})_{\text{vir}} \otimes (\text{NS})_{\widehat{\mathfrak{so}}(10)_1}\right) &= 0, & Q\left((\text{NS})_{\text{vir}} \otimes (\text{R})_{\widehat{\mathfrak{so}}(10)_1}\right) &\neq 0, \\
Q\left((\text{R})_{\text{vir}} \otimes (\text{R})_{\widehat{\mathfrak{so}}(10)_1}\right) &= 0, & Q\left((\text{R})_{\text{vir}} \otimes (\text{NS})_{\widehat{\mathfrak{so}}(10)_1}\right) &\neq 0.
\end{aligned}$$

Therefore, the simple current construction projects onto states which are in the Neveu–Schwarz sector of the $\mathcal{N} = 2$ factor and in the Neveu–Schwarz sector of the $\widehat{\mathfrak{so}}(10)_1$ theory, respectively, onto states which are both in the Ramond sector. This gives us a clear distinction between those two sectors.

Simple Current Construction II

What we are interested in are theories with space–time supersymmetry, that is, we are looking for a symmetry exchanging bosonic and fermionic fields in the four-dimensional theory. From string theory, we know that states in the Neveu–Schwarz sector become space–time bosons and that states in the Ramond sector become space–time fermions. Therefore, if we have a one-to-one map between the Neveu–Schwarz and Ramond sectors, we have a good candidate for a space–time supercharge. For $\mathcal{N} = 2$ SCFTs, we have such a map available, namely the spectral flow operator, which is the reason we started with $\mathcal{N} = 2$ SCFTs in the first place. In the following, we will now perform a second simple current projection such that we achieve space–time supersymmetry.

In Sect. 5.4, we have determined the spectral flow operator for the minimal models to be $\phi_{1,1}^0$, and from the fusion rules (5.45) we see that S maps states in the Ramond sector to the Neveu–Schwarz sector and vice versa. For the combined theory (5.47), we therefore find

$$J_{\text{sf}} = (0, 1, 1)^r(S). \quad (5.50)$$

However, the spectral flow operator is also a simple current which can be seen for the minimal model part from below Eq. (5.41). From the fusion rules (5.45), we see that also S is a simple current and so J_{sf} is a simple current for the full tensor theory. Let us now collect some more data about J_{sf} . The conformal weight of the simple current (5.50) is computed as

$$h(J_{\text{sf}}) = \sum_i (h_{1,1}^0)_i + h_S = \sum_i \left(\frac{-1}{4(k_i + 2)} + \frac{1}{8} \right) + \frac{5}{8} = \sum_i \frac{c_i}{24} + \frac{5}{8} = 1 ,$$

where we used that $\sum_i c_i = 9$. Recalling from Eq. (5.43) the $U(1)$ charges of the $\widehat{\mathfrak{so}}(10)_1$ representations (O, V, S, C) as $(0, 1, 1/2, -1/2)$, we similarly determine

$$q(J_{\text{sf}}) = \sum_i (q_{1,1})_i + q_S = \sum_i \left(-\frac{1}{k_i + 2} + \frac{1}{2} \right) + \frac{1}{2} = \sum_i \frac{c_i}{6} + \frac{1}{2} = 2 .$$

Next, let us calculate the monodromy charge of a general state (5.48) with respect to Eq. (5.50). To do so, we note that from the fusion rules (5.41) the action of the spectral flow operator on a state $\bigotimes_i (l_i, m_i, s_i) \otimes (s_0)$ is found as

$$J_{\text{sf}}(\text{state}) = \bigotimes_i (l_i, m_i + 1, s_i + 1) \otimes (s_0 + 1) ,$$

where we also used that $0 \leq |m - s| \leq l$. The conformal weights of such a state and the one acted upon by J_{sf} are computed as follows

$$\begin{aligned} h(\text{state}) &= \sum_i \left(\frac{l_i(l_i + 2) - m_i^2}{4(k_i + 2)} + \frac{s_i^2}{8} \right) + \left(\frac{s_0^2}{8} + \frac{1}{2} \delta(S, C) \right) , \\ h(J_{\text{sf}}(\text{state})) &= \sum_i \left(\frac{l_i(l_i + 2) - (m_i + 1)^2}{4(k_i + 2)} + \frac{(s_i + 1)^2}{8} \right) \\ &\quad + \left(\frac{(s_0 + 1)^2}{8} + \frac{1}{2} \delta(S, C) \right) , \end{aligned}$$

where $\delta(S, C)$ is one if the state contains a factor S or C and it is zero otherwise. The monodromy charge (4.72) for a general state (5.48) is then obtained in the following way:

$$\begin{aligned} Q(\text{state}) &= h(J_{\text{sf}}) + h(\text{state}) - h(J_{\text{sf}} \times \text{state}) \pmod{1} \\ &= 1 + \sum_i \left(\frac{2m_i + 1}{4(k_i + 2)} - \frac{2s_i + 1}{8} \right) - \frac{2s_0 + 1}{8} - \frac{1}{2} + \delta(S, C) \pmod{1} \\ &= \sum_i \left(\frac{m_i}{2(k_i + 2)} - \frac{s_i}{4} \right) - \frac{s_0}{4} \\ &\quad + \sum_i \left(\frac{1}{4(k_i + 2)} - \frac{1}{8} \right) - \frac{1}{8} + \frac{1}{2} + \delta(S, C) \pmod{1} \\ &= \sum_i \left(\frac{m_i}{2(k_i + 2)} - \frac{s_i}{4} \right) - \frac{s_0}{4} - \sum_i \frac{c_i}{24} + \frac{3}{8} + \delta(S, C) \pmod{1} . \end{aligned}$$

Before performing the last step and using that $\sum_i c_i = 9$, let us note that the $U(1)$ charge of the state under consideration has the following form:

$$q_{\text{state}} = \sum_i \left(-\frac{m_i}{k_i + 2} + \frac{s_i}{2} \right) + \frac{s_0}{2},$$

where we employed again Eq. (5.17). With the help of this result, we see that the monodromy charge above can be simplified as

$$Q(\text{state}) = -\frac{q_{\text{state}}}{2} \pmod{1}.$$

For the simple current construction this implies that only those states whose $U(1)$ charge satisfies $q_{\text{state}} \in 2\mathbb{Z}$ appear in the modular invariant partition function. Therefore,

The simple current J_{sf} projects onto states with charge $q_{\text{state}} \in 2\mathbb{Z}$.

Modular Invariant Partition Function

After having studied the simple currents and corresponding monodromy charges of the states, let us now proceed and construct the modular invariant partition function of the bosonic string. According to Sect. 4.7 and in particular Eq. (4.80), schematically it reads

$$\mathcal{Z}_{(24,24)} = \frac{1}{\mathcal{N}} \vec{\chi}^T(\tau) M(J_{\text{sf}}) \prod_{i=1}^K M(J_i) \vec{\chi}(\bar{\tau}),$$

where \mathcal{N} is an overall normalisation constant fixed by the requirement that the vacuum appears precisely once. Furthermore, in this compact notation we have introduced the matrices $M(J)$ containing the information about which holomorphic characters couple to which anti-holomorphic ones due to the extension by the simple current J . From this bosonic string partition function, we can generate a supersymmetric one by applying the bosonic string map (5.46) from the beginning of this section. Instead of dealing with a $\widehat{\mathfrak{so}}(10)_1 \times (\widehat{\mathfrak{e}}_8)_1$ Kač–Moody algebra, we thus work with $\widehat{\mathfrak{so}}(2)_1$.

In order to be more precise, let us introduce some notation to give an explicit expression for the supersymmetric modular invariant partition function after the bosonic string map has been applied. We define the characters and the so-called charge vector as

$$\chi_{\vec{\lambda}}^{\vec{l}}(\tau) := \prod_{i=1}^r \chi_{m_i, s_i}^{l_i}(\tau) \cdot \chi_{s_0}^{\widehat{\mathfrak{so}}(2)_1}(\tau) \quad \text{with } \vec{\lambda} = (s_0, m_1, \dots, m_r, s_1, \dots, s_r)$$

and $\vec{l} = (l_1, \dots, l_r)$. Between two charge vectors, a scalar product is given by

$$\vec{\lambda} \cdot \vec{\mu} = \frac{s_0 s'_0}{4} + \frac{1}{2} \sum_{i=1}^r \left(-\frac{m_i m'_i}{k_i + 2} + \frac{s_i s'_i}{2} \right),$$

and the charge vector for the simple currents J_i from Eq. (5.49) is determined to be

$$\beta_i = (2, 0, \dots, 0, 0, \dots, 2, \dots, 0).$$

\uparrow
*i*th position

Let us then recall that for the $\mathcal{N} = 2$ unitary models as well as for the $\widehat{\mathfrak{so}}(2)_1$ Kač–Moody algebras, states with $s = 0, 2$ correspond to the Neveu–Schwarz sector while those with $s = \pm 1$ correspond to the Ramond sector. As we have seen previously, only states purely in the Neveu–Schwarz or purely in the Ramond sector will survive the simple current projection with respect to Eq. (5.49). In terms of the charge vector and after the bosonic string map has been applied, this is expressed as

$$\vec{\beta}_i \cdot \vec{\lambda} \in \mathbb{Z}.$$

From Eq. (5.50), we see that the charge vector for the spectral flow simple current J_{sf} reads

$$\vec{\beta}_0 = (-1, 1, \dots, 1, 1, \dots, 1),$$

and the condition $q_{\text{state}} \in 2\mathbb{Z}$ becomes

$$2\vec{\beta}_0 \cdot \vec{\lambda} \in 2\mathbb{Z} + 1,$$

where the $+1$ is due to the bosonic string map. This projection is called the GSO projection and corresponds to the fermion number operator $(-1)^f$ we have already encountered in Sect. 2.9.2.

Finally, we can now write down the simple current extended, modular invariant, supersymmetric partition function from above more concretely as

$$\mathcal{Z}_{\text{Gepner}}(\tau, \bar{\tau}) = \frac{1}{\mathcal{N}} \sum_{\vec{l}, \vec{\lambda}} \sum_{\substack{v_i=0,1 \\ \vec{\lambda} \cdot \vec{\beta}_i \in \mathbb{Z} \\ \vec{\lambda} \cdot \vec{\beta}_0 \in 2\mathbb{Z}+1}} \sum_{v_0=0}^{L-1} \chi_{\vec{\lambda}}^{\vec{l}}(\tau) \bar{\chi}_{\vec{\lambda} + \sum_{i=1}^r v_i \beta_i + v_0 \beta_0}^{\vec{l}}(\bar{\tau}) (-1)^{v_0}, \quad (5.51)$$

where L is the length of the simple current J_{sf} and \mathcal{N} is again an overall normalisation constant. Due to the bosonic string map, states in the (NS,R) and (R,NS) sector, which are space–time fermions, contribute a (-1) sign in this supersymmetric partition function. Note that here (and in the following), (NS,R) refers to

the Neveu–Schwarz sector of the holomorphic and to the Ramond sector of the anti-holomorphic CFT, and similarly for the other three combinations.

Note also that by applying the bosonic string map only to the anti-holomorphic sector, one can similarly define a heterotic string Gepner model. This was done in the original work by D. Gepner, to which we refer the reader for further details.

5.7 Massless Modes of Gepner Models

In the last section of this chapter, we are going to discuss the Type IIB string theory Gepner model partition function (5.51) in some more detail. In particular, in string theory one is interested in the massless excitations of the string which in the present situation correspond to states in the partition function with conformal weight $(h, \bar{h}) = (\frac{1}{2}, \frac{1}{2})$. Since the simple current construction has arranged all states into orbits, we can distinguish for instance the massless vacuum orbit in the partition function $\mathcal{Z}_{\text{Gepner}}(\tau, \bar{\tau})$ from other massless orbits via the $U(1)$ charge.

Let us also mention that because the partition function (5.51) is left–right symmetric, one obtains $\mathcal{N} = 2$ space–time supersymmetry in four dimensions. For the heterotic string, where the holomorphic sector remains bosonic, one only finds $\mathcal{N} = 1$ space–time supersymmetry and the holomorphic spectral flow extends the manifest $SO(10) \times U(1)$ gauge symmetry to E_6 .

Massless Modes in the Vacuum Orbit

Let us consider first the vacuum orbit. The vacuum with $(h, q) = (0, 0)$ in the Neveu–Schwarz/Neveu–Schwarz of the bosonic string theory reads $(0, 0, 0)^r(O) \otimes \overline{(0, 0, 0)^r(O)}$ which is mapped to

$$(0, 0, 0)^r(V) \otimes \overline{(0, 0, 0)^r(V)}$$

under the bosonic string map. Taking into account that the ground state (V) of $\widehat{\mathfrak{so}}(2)_1$ is two-dimensional, these are four states corresponding in four dimensions to the graviton $g_{\mu\nu}$, the anti-symmetric two-form $B_{\mu\nu}$ and the dilaton ϕ . However, due to the simple current construction, there are further states in that orbit. In particular, we find four additional massless states in the (R,R) sector

$$\begin{aligned} (0, +1, +1)^r(C) \otimes \overline{(0, +1, +1)^r(C)}, & \quad (0, -1, -1)^r(S) \otimes \overline{(0, -1, -1)^r(S)}, \\ (0, +1, +1)^r(C) \otimes \overline{(0, -1, -1)^r(S)}, & \quad (0, +1, +1)^r(C) \otimes \overline{(0, -1, -1)^r(S)}, \end{aligned}$$

which are space–time bosons. Since $[C] \times [C] = [S] \times [S] = [V]$ and $[S] \times [C] = [C] \times [S] = [O]$, these four states are identified in four dimensions as one massless vector and one massless complex scalar. Of course, we are also expecting the fermionic superpartners of all these bosonic fields, which indeed arise in the (NS,R) and (R,NS) sectors

$$(0, 0, 0)^r(V) \otimes \overline{(0, +1, +1)^r(C)}, \quad (0, +1, +1)^r(S) \otimes \overline{(0, 0, 0)^r(V)},$$

$$(0, 0, 0)^r(V) \otimes \overline{(0, -1, -1)^r(S)}, \quad (0, -1, -1)^r(S) \otimes \overline{(0, 0, 0)^r(V)}.$$

These eight space–time bosons and eight space–time fermions constitute the contents of the $\mathcal{N} = 2$ gravity supermultiplet and one further $\mathcal{N} = 2$ hypermultiplet. Note that the gravity supermultiplet contains in addition to the spin = 2 graviton one spin = 1 vectorfield. The hypermultiplet contains in particular the dilaton and generically appears in string theory. For this reason it is also called the universal hypermultiplet.

Massless Modes in Charged Orbits

The vacuum orbit is always present for all Gepner models whereas the structure of the massless charged orbits depends on the specific details of the $c = 9$ tensor product theory. However, since massless states have $h = \bar{h} = 1/2$ and due to the odd $U(1)$ charge, all these states must be (anti-)chiral primary states in the $\mathcal{N} = 2$ SCFT. Concretely, in the charged orbits we find massless states of the form

$$\left(\left(\frac{1}{2}, -1 \right) (O) + \left(\frac{3}{8}, +\frac{1}{2} \right) (S) \right) \otimes \overline{\left(\left(\frac{1}{2}, -1 \right) (O) + \left(\frac{3}{8}, +\frac{1}{2} \right) (S) \right)},$$

$$\left(\left(\frac{1}{2}, +1 \right) (O) + \left(\frac{3}{8}, -\frac{1}{2} \right) (C) \right) \otimes \overline{\left(\left(\frac{1}{2}, +1 \right) (O) + \left(\frac{3}{8}, -\frac{1}{2} \right) (C) \right)},$$

where we used (h, q) to denote the conformal weight and charge of the corresponding state. For each such orbit, including all combinations of NS and R sectors, we obtain one vector, one complex boson and four fermionic states forming one $\mathcal{N} = 2$ vectormultiplet $(\phi^c, \lambda^\alpha, A_\mu)$.

However, it can also happen that in an orbit of $(\frac{1}{2}, -1)(O)$, there appears a state with

$$\left(\frac{1}{2}, +1 \right) (O) + \left(\frac{3}{8}, -\frac{1}{2} \right) (C),$$

which, by including all NS and R sectors, gives rise to an $\mathcal{N} = 2$ hypermultiplet. Whether this happens or not depends on the concrete model.

Example

Let us finally discuss the massless spectrum for the $(k = 3)^5$ Gepner model in some more detail. Each $(k = 3)$ tensor factor has chiral states $(0, 0, 0)_0$, $(1, -1, 0)_{\frac{1}{3}}$, $(2, -2, 0)_{\frac{2}{3}}$ and $(3, -3, 0)_{\frac{3}{3}}$, where the subscript denotes the $U(1)$ charge. We can now make a list of all the combinatorial possibilities to form chiral states with $(h, q) = (\frac{1}{2}, 1)$ in the tensor product $(k = 3)^5$ theory. This list reads

$(3, -3, 0)$	$(2, -2, 0)$	$(0, 0, 0)^3$	20
$(3, -3, 0)$	$(1, -1, 0)^2$	$(0, 0, 0)^2$	30
$(2, -2, 0)^2$	$(1, -1, 0)$	$(0, 0, 0)^2$	30
$(2, -2, 0)$	$(1, -1, -1)^3$	$(0, 0, 0)$	20
$(1, -1, 0)^5$			1
			101

and by counting states, we see that there are 101 vectormultiplets. A more detailed investigation reveals that only the orbit of $(1, -1, 0)^5(O)$ contains a state with $(h, q) = (\frac{1}{2}, -1)$, namely $(1, 1, 0)^5(O)$, giving one hypermultiplet.

As it turns out, Type IIB string theory compactified on a Calabi–Yau manifold with Hodge numbers (h^{21}, h^{11}) gives rise to h^{21} vectormultiplets and h^{11} hypermultiplets. A Calabi–Yau manifold with Hodge numbers $(h^{21}, h^{11}) = (101, 1)$ is the so-called Quintic defined via the constraint

$$\sum_{i=1}^5 z_i^5 = 0 \quad \text{in } \mathbb{CP}^4.$$

Apart from the counting of multiplets illustrated above, more evidence has been collected that indeed the Gepner model $(k = 3)^5$ exactly solves the non-linear sigma model on the Quintic (at fixed size).

Remarks

- In the heterotic string $(k = 3)^5$ Gepner model, one obtains in four dimensions an $\mathcal{N} = 1$ super Yang–Mills theory with gauge group E_6 and $N_{27} = 101$ chiral matter superfields in the fundamental representation of E_6 and $N_{\bar{27}} = 1$ chiral superfields in the anti-fundamental representation. Here, the SCFT construction can be generalised to also lead to other GUT gauge groups such as $SO(10)$ or $SU(5)$.
- Without a detailed introduction into string theory, we could only present the basic ingredients for the Gepner construction which we hope has convinced the reader what powerful role abstract SCFTs can play. Also, as we have seen, many of the techniques developed in the previous chapters find an interesting application in the Gepner construction.

Further Reading

1. D. Friedan, Z.-a. Qiu, and S. H. Shenker, “Superconformal invariance in two-dimensions and the tricritical ising model,” *Phys. Lett.* **B151** (1985) 37–43.
2. T. Banks, L. J. Dixon, D. Friedan, and E. J. Martinec, “Phenomenology and conformal field theory or can string theory predict the weak mixing angle?,” *Nucl. Phys.* **B299** (1988) 613–626.
3. W. Lerche, C. Vafa, and N. P. Warner, “Chiral rings in N=2 superconformal theories,” *Nucl. Phys.* **B324** (1989) 427.

4. D. Gepner, "Space-time supersymmetry in compactified string theory and superconformal models," *Nucl. Phys.* **B296** (1988) 757.
5. D. Gepner, "Exactly solvable string compactifications on manifolds of $SU(N)$ holonomy," *Phys. Lett.* **B199** (1987) 380–388.

Chapter 6

Boundary Conformal Field Theory

In the previous chapters, we have discussed conformal field theories defined on (compact) Riemann surfaces such as the sphere or the torus. In string theory, these CFTs are relevant for the sector of closed strings. However, string theory also contains open strings whose world-sheets have boundaries. Therefore, in order to describe the dynamics of open strings, it is necessary to study the so-called boundary conformal field theories (BCFTs). Again in string theory, boundaries have the interpretation of defects in the target space where open strings can end and such objects are called D-branes (see Fig. 6.1). Furthermore, the concept of D-branes can be generalised to abstract CFTs, which are neither free bosons nor free fermions.

In this chapter, we give an introduction to the field of BCFT which is still an active field of research. To do so, we focus on the example of the free boson and then generalise the appearing structure to more general CFTs.

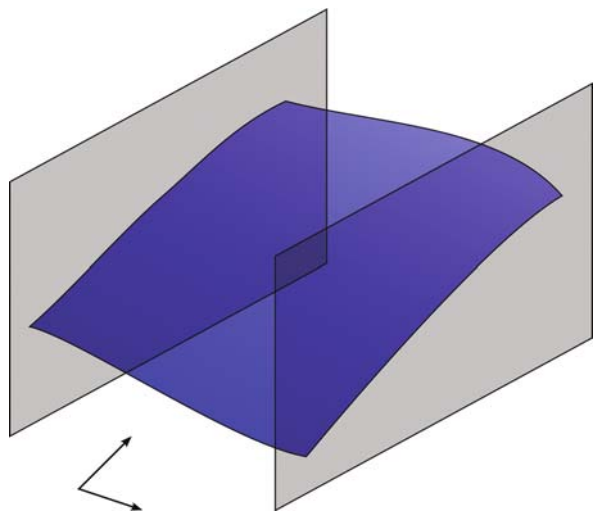

Fig. 6.1 Two-dimensional surface with boundaries which can be interpreted as an open string world-sheet stretched between two D-branes

6.1 The Free Boson with Boundaries

6.1.1 Boundary Conditions

We start by discussing the boundary conformal field theory of the free boson theory introduced in Sect. 2.9.1 in order to illustrate the appearance of boundaries from a Lagrangian and geometrical point of view.

Conditions for the Fields

The two-dimensional action for a free boson $X(\tau, \sigma)$ was given in Eq. (2.75) which we recall for convenience

$$\mathcal{S} = \frac{1}{4\pi} \int d\sigma d\tau \left((\partial_\sigma X)^2 + (\partial_\tau X)^2 \right). \quad (6.1)$$

Note that we fixed the overall normalisation constant and we slightly changed our notation such that $\tau \in (-\infty, +\infty)$ denotes the two-dimensional time coordinate and $\sigma \in [0, \pi]$ is the coordinate parametrising the distance between the boundaries.

The variation of the action (6.1) is obtained similarly as in section *The Free Boson*, but now with the boundary terms taken into account. More specifically, we compute the variation as follows:

$$\begin{aligned} \delta_X \mathcal{S} &= \frac{1}{\pi} \int d\sigma d\tau \left((\partial_\sigma X) (\partial_\sigma \delta X) + (\partial_\tau X) (\partial_\tau \delta X) \right) \\ &= \frac{1}{\pi} \int d\sigma d\tau \left(-(\partial_\sigma^2 + \partial_\tau^2) X \cdot \delta X + \partial_\tau (\partial_\tau X \cdot \delta X) + \partial_\sigma (\partial_\sigma X \cdot \delta X) \right). \end{aligned} \quad (6.2)$$

The equation of motion is obtained by requiring this expression to vanish for all variations δX . The vanishing of the first term in the last line leads to $\square X = 0$ which we already obtained previously. The remaining two terms can be written as follows:

$$\begin{aligned} &\frac{1}{\pi} \int d\sigma d\tau \left(\partial_\tau (\partial_\tau X \cdot \delta X) + \partial_\sigma (\partial_\sigma X \cdot \delta X) \right) \\ &= \frac{1}{\pi} \int d\sigma d\tau \vec{\nabla} \cdot (\vec{\nabla} X \delta X) \\ &= \frac{1}{\pi} \int_{\mathcal{B}} dl_{\mathcal{B}} (\vec{\nabla} X \cdot \vec{n}) \delta X, \end{aligned}$$

where we introduced $\vec{\nabla} = (\partial_\tau, \partial_\sigma)^T$ and used Stokes theorem to rewrite the integral $\int d\sigma d\tau$ as an integral over the boundary \mathcal{B} . Furthermore, $dl_{\mathcal{B}}$ denotes the line element along the boundary and \vec{n} is a unit vector normal to \mathcal{B} . In our case, the boundary is specified by $\sigma = 0$ and $\sigma = \pi$ so that $\vec{n} = (0, \pm 1)^T$ as well as $dl_{\mathcal{B}} = d\tau$. The vanishing of the last two terms in Eq. (6.2) can therefore be expressed as

$$0 = \frac{1}{\pi} \int d\tau (\partial_\sigma X) \delta X \Big|_{\sigma=0}^{\sigma=\pi} .$$

This equation allows for two different solutions and hence for two different boundary conditions. The first possibility is a Neumann boundary condition given by $\partial_\sigma X|_{\sigma=0,\pi} = 0$. The second possibility is a Dirichlet condition $\delta X|_{\sigma=0,\pi} = 0$ for all τ which implies $\partial_\tau X|_{\sigma=0,\pi} = 0$. In summary, the two different boundary conditions for the free boson theory read as follows:

$\partial_\sigma X _{\sigma=0,\pi} = 0$	Neumann condition,	(6.3)
$\delta X _{\sigma=0,\pi} = 0 = \partial_\tau X _{\sigma=0,\pi}$	Dirichlet condition.	

Remark

Let us remark that in string theory, a hypersurface in space–time where open strings can end is called a D-brane. In order to explain this point, let us consider a theory of N free bosons $X^\mu(\tau, \sigma)$ with $\mu = 0, \dots, N - 1$ which describe the motion of a string in an N -dimensional space–time. We organise the fields in the following way:

$$\left(\underbrace{X^0, X^1, \dots, X^{r-1}}_{\text{Neumann conditions}}, \underbrace{X^r, \dots, X^{N-1}}_{\text{Dirichlet conditions}} \right),$$

where r denotes the number of bosons with Neumann boundary conditions leaving $(N - r)$ bosons with Dirichlet conditions.

Let us now focus on one endpoint of the open string, say at $\sigma = 0$. A Dirichlet boundary condition for X^μ reads $\delta X^\mu|_{\sigma=0} = 0$ which means that the endpoint of the open string is fixed to a particular value $x_0^\mu = \text{const}$. However, in case of Neumann boundary conditions, there is no restriction on the position of the string endpoint which can therefore take any value. Clearly, since the string moves in time, there are Neumann conditions for the time coordinate X^0 . Then, the r -dimensional hypersurface in space–time described by $X^\mu = x_0^\mu = \text{const}$. for $\mu = r, \dots, N - 1$ is called a $D(r - 1)$ -brane where the symbol D stands for Dirichlet.

As an example, take $N = 3$ and consider Fig. 6.1 where we see a world-sheet of an open string stretched between two D1-branes.

Conditions for the Laurent Modes

Above, we have considered the BCFT in terms of the real variables (τ, σ) which was convenient in order to arrive at Eq. (6.3). However, as we have seen in all the previous chapters, for more advanced studies a description in terms of complex variables is very useful. Similarly as before, a mapping from the infinite strip described by the real variables (τ, σ) to the complex upper half-plane H^+ is achieved by

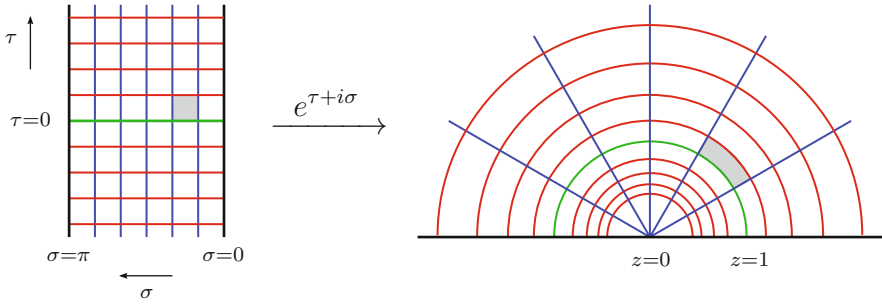

Fig. 6.2 Illustration of the map $z = \exp(\tau + i\sigma)$ from the infinite strip to the complex upper half-plane H^+

$z = \exp(\tau + i\sigma)$. Note in particular, as illustrated in Fig. 6.2, the boundary $\sigma = 0, \pi$ is mapped to the real axis $z = \bar{z}$.

Having this map in mind, we can express the boundary conditions (6.3) for the field $X(\sigma, \tau)$ in terms of the corresponding Laurent modes. Recalling that $j(z) = i \partial X(z, \bar{z})$, we find

$$\begin{aligned} \partial_\sigma X &= i(\partial - \bar{\partial})X = j(z) - \bar{j}(\bar{z}) = \sum_{n \in \mathbb{Z}} (j_n z^{-n-1} - \bar{j}_n \bar{z}^{-n-1}), \\ i \cdot \partial_\tau X &= i(\partial + \bar{\partial})X = j(z) + \bar{j}(\bar{z}) = \sum_{n \in \mathbb{Z}} (j_n z^{-n-1} + \bar{j}_n \bar{z}^{-n-1}), \end{aligned}$$

where we used the explicit expressions for ∂ and $\bar{\partial}$ from p. 12. For transforming the right-hand side of these equations as $z \mapsto e^w$ with $w = \tau + i\sigma$, we employ that $j(z)$ is a primary field of conformal dimension $h = 1$. In particular, recalling Eq. (2.17), we have $j(z) = \left(\frac{\partial z}{\partial w}\right)^1 j(w) = z j(w)$ leading to

$$\begin{aligned} \partial_\sigma X &= \sum_{n \in \mathbb{Z}} (j_n e^{-n(\tau+i\sigma)} - \bar{j}_n e^{-n(\tau-i\sigma)}), \\ i \cdot \partial_\tau X &= \sum_{n \in \mathbb{Z}} (j_n e^{-n(\tau+i\sigma)} + \bar{j}_n e^{-n(\tau-i\sigma)}). \end{aligned} \tag{6.4}$$

The Neumann as well as the Dirichlet boundary conditions at $\sigma = 0$ are then easily obtained as

$$\begin{aligned} \partial_\sigma X \Big|_{\sigma=0} &= \sum_{n \in \mathbb{Z}} (j_n - \bar{j}_n) e^{-n\tau} = 0, \\ \partial_\tau X \Big|_{\sigma=0} &= \sum_{n \in \mathbb{Z}} (j_n + \bar{j}_n) e^{-n\tau} = 0. \end{aligned}$$

Since for generic τ the summands above are linearly independent, these two equations are solved by $j_n \pm \bar{j}_n = 0$ for all n , respectively. In summary, we note that boundaries introduce relations between the chiral and the anti-chiral modes of the conformal fields which read

$ \begin{aligned} j_n - \bar{j}_n &= 0 && \text{Neumann condition,} \\ j_n + \bar{j}_n &= 0, && (\pi_0 = 0) \quad \text{Dirichlet condition.} \end{aligned} $	(6.5)
--	-------

From a string theory point of view, Eq. (6.5) implies that an open string has only half the degrees of freedom of a closed string.

Let us now recall from Eq. (2.91) our computation of the centre of mass momentum of a closed string. Since for open strings we have $\sigma \in [0, \pi]$ instead of $\sigma \in [0, 2\pi]$, we obtain in the present case that

$$\pi_0 = \frac{1}{2} j_0 = \frac{1}{2} \bar{j}_0. \tag{6.6}$$

In view of Eq. (6.5), we thus see that there are no restrictions on π_0 for Neumann boundary conditions and so the endpoints of the string are free to move along the D-brane. For Dirichlet conditions on the other hand, we have $\pi_0 = 0$ implying that the endpoints are fixed.

Combined Boundary Condition

In the previous paragraph, we have considered the boundary at $\sigma = 0$. Let us now turn to the other boundary at $\sigma = \pi$. Performing the same steps as before, we see that Neumann–Neumann as well as Dirichlet–Dirichlet conditions are characterised by the constraints found in Eq. (6.5).

However, mixed boundary conditions, e.g. Neumann–Dirichlet, require a modification. In particular, $j_n - \bar{j}_n = 0$ at $\sigma = 0$ and $j_n + \bar{j}_n e^{-2in\sigma} = 0$ at $\sigma = \pi$ can only be solved for $n \in \mathbb{Z} + \frac{1}{2}$. All possible combinations of boundary conditions are then summarised as

$j_n - \bar{j}_n = 0,$	$n \in \mathbb{Z}$	Neumann–Neumann,
$j_n - \bar{j}_n = 0,$	$n \in \mathbb{Z} + \frac{1}{2}$	Neumann–Dirichlet,
$j_n + \bar{j}_n = 0,$	$n \in \mathbb{Z} + \frac{1}{2}$	Dirichlet–Neumann,
$j_n + \bar{j}_n = 0,$	$n \in \mathbb{Z}$	Dirichlet–Dirichlet.

Solutions to the Boundary Condition

Next, let us determine the solutions to the boundary conditions stated above. First, we integrate Eq. (6.4) to obtain $X(\tau, \sigma)$ in the closed sector

$$X(\tau, \sigma) = x_0 - i(\tau + i\sigma)j_0 - i(\tau - i\sigma)\bar{j}_0 + \sum_{n \neq 0} \frac{i}{n} \left(j_n e^{-n(\tau+i\sigma)} + \bar{j}_n e^{-n(\tau-i\sigma)} \right), \quad (6.7)$$

where x_0 is an integration constant. We then implement the boundary conditions to project onto the open sector. For the Neumann–Neumann case, we find

$$X^{(N,N)}(\tau, \sigma) = x_0 - 2i\tau j_0 + 2i \sum_{n \neq 0} \frac{j_n}{n} e^{-n\tau} \cos(n\sigma),$$

and for the Dirichlet–Dirichlet case, we obtain along the same lines

$$X^{(D,D)}(\tau, \sigma) = x_0 + 2\sigma j_0 + 2 \sum_{n \neq 0} \frac{j_n}{n} e^{-n\tau} \sin(n\sigma).$$

Having arrived at this solution, we can become more concrete about the Dirichlet–Dirichlet boundary conditions. We impose that $X(\tau, \sigma = 0) = x_0^a$ and $X(\tau, \sigma = \pi) = x_0^b$, which means that the endpoints of the string are fixed at positions x_0^a and x_0^b . Using the explicit solution for $X^{(D,D)}(\tau, \sigma)$, we obtain the relation

$$\boxed{j_0 = \frac{x_0^b - x_0^a}{2\pi}}. \quad (6.8)$$

Finally, for completeness, the solutions for the case of mixed Neumann–Dirichlet boundary conditions read as follows:

$$X^{(N,D)}(\tau, \sigma) = x_0 + 2i \sum_{n \in \mathbb{Z} + \frac{1}{2}} \frac{j_n}{n} e^{-n\tau} \cos(n\sigma),$$

$$X^{(D,N)}(\tau, \sigma) = x_0 + 2 \sum_{n \in \mathbb{Z} + \frac{1}{2}} \frac{j_n}{n} e^{-n\tau} \sin(n\sigma).$$

Note that the index of the Laurent modes in this sector is the same as for the twisted sector of the free boson \mathbb{Z}_2 -orbifold discussed in Sect. 4.2.5.

Conformal Symmetry

Let us remark that Eq. (6.5) apply to the Laurent modes of the two $U(1)$ currents $j(z)$ and $\bar{j}(\bar{z})$ of the free boson theory leaving only a diagonal $U(1)$ symmetry. However, in addition there is always the conformal symmetry generated by the energy–momentum tensor. Since boundaries in general break certain symmetries, we expect also restrictions on the Laurent modes of energy–momentum tensor.

Indeed, recalling that $T(z)$ and $\bar{T}(\bar{z})$ can be expressed in terms of the currents $j(z)$ and $\bar{j}(\bar{z})$ in the following way:

$$T(z) = \frac{1}{2} N(j j)(z), \quad \bar{T}(\bar{z}) = \frac{1}{2} N(\bar{j} \bar{j})(\bar{z}),$$

we find that the Neumann as well as the Dirichlet boundary conditions (6.5) imply for $L_n = \frac{1}{2} N(j j)_n$ that

$$\boxed{L_n - \bar{L}_n = 0}. \quad (6.9)$$

Let us emphasise that this condition can be expressed as $T(z) = \bar{T}(\bar{z})$ which in particular means the central charges of the holomorphic and anti-holomorphic theories have to be equal, i.e. $c = \bar{c}$. For string theory, this observation has the immediate implication that boundaries, that is, D-branes, can only be defined for the Type II Superstring Theories, as opposed to the heterotic string theories.

6.1.2 Partition Function

Definition

Let us now consider the one-loop partition function for BCFTs. To do so, we first review the construction for the case without boundaries and then compare with the present situation.

- In Sect. 4.1, we defined the one-loop partition function for CFTs without boundaries as follows. We started from a theory defined on the infinite cylinder described by (τ, σ) , where σ was periodic and $\tau \in (-\infty, +\infty)$. Next, we imposed periodicity conditions also on the time coordinate τ yielding the topology of a torus.
- In the present case, the space coordinate σ is not periodic and thus we start from a theory defined on the infinite strip given by $\sigma \in [0, \pi]$ and $\tau \in (-\infty, +\infty)$. For the definition of the one-loop partition function, we again make the time coordinate τ periodic leaving us with the topology of a cylinder instead of a torus. This is illustrated in Fig. 6.3.
- Similarly to the modular parameter of the torus, there is a modular parameter t with $0 \leq t < \infty$ parametrising different cylinders. The inequivalent cylinders are described by $\{(\tau, \sigma) : 0 \leq \sigma \leq \pi, 0 \leq \tau \leq t\}$.

For the partition function, we need to determine the operator generating translations in time circling the cylinder once along the τ direction. Because boundaries lead to an identification of the left- and right-moving sector as required by Eq. (6.9), we see that this operator is the Hamiltonian say in the open sector

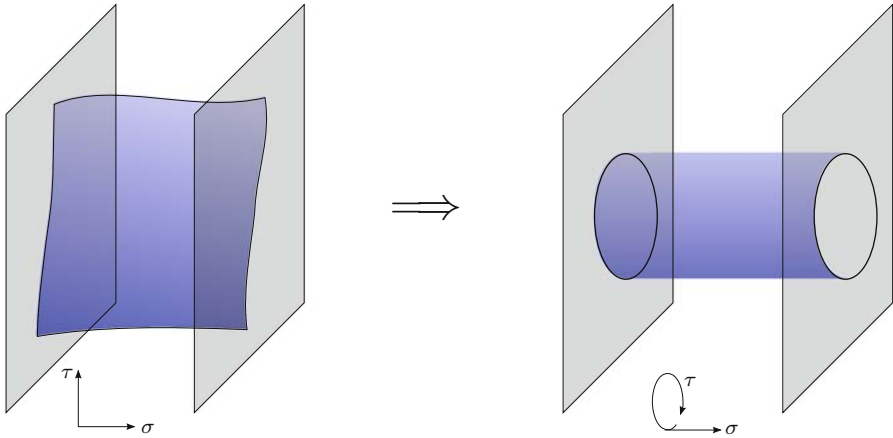

Fig. 6.3 Illustration how the cylinder partition function is obtained from the infinite strip by cutting out a finite piece and identifying the ends

$$H_{\text{open}} = (L_{\text{cyl.}})_0 = L_0 - \frac{c}{24} ,$$

which we inferred from the closed sector Hamiltonian $H_{\text{closed}} = (L_{\text{cyl.}})_0 + (\bar{L}_{\text{cyl.}})_0$. In analogy to the case of the torus partition function, we then define the cylinder partition function as $\mathcal{Z} = \text{Tr} \exp(-2\pi t H_{\text{open}})$ which can be brought into the following form:

$$\mathcal{Z}^{\mathcal{C}}(t) = \text{Tr}_{\mathcal{H}_B} \left(q^{L_0 - \frac{c}{24}} \right) \quad \text{where} \quad q = e^{-2\pi t} .$$

Here, the superscript \mathcal{C} on \mathcal{Z} indicates the cylinder partition function and \mathcal{H}_B denotes the Hilbert space of all states satisfying one of the boundary conditions (6.5). Clearly, from a string theory point of view, this is just the Hilbert space of an open string.

Free Boson I: Cylinder Partition Function (Loop-Channel)

We close this section by determining the cylinder partition function for the free boson. Recalling our calculation from p. 121 and setting $\tau = it$, we obtain

$$\text{Tr}_{\mathcal{H}_B} \left(q^{L_0 - \frac{c}{24}} \right) \Big|_{\text{without } j_0} = \frac{1}{\eta(it)} .$$

However, there we have assumed the action of j_0 on the vacuum to vanish, which in the case of string theory is in general not applicable. Taking into account the effect of j_0 , we now study the three different cases of boundary conditions in turn.

- For the case of Neumann–Neumann boundary conditions, the momentum mode $\pi_0 = \frac{1}{2} j_0$ is unconstrained and in principle contributes to the trace. Since it is a continuous variable, the sum is replaced by an integral

$$\mathrm{Tr}_{\mathcal{H}_B} \left(q^{\frac{1}{2} j_0^2} \right) = \sum_{n_0} \langle n_0 | e^{-\pi t j_0^2} | n_0 \rangle = \sum_{n_0} e^{-\pi t n_0^2} \longrightarrow \int_{-\infty}^{\infty} d\pi_0 e^{-4\pi t \pi_0^2},$$

where we utilised $n_0 = 2\pi_0$. Evaluating this Gaussian integral leads to the following additional factor for the partition function:

$$\frac{1}{2\sqrt{t}}. \quad (6.10)$$

- For the Dirichlet–Dirichlet case, we have seen in Eq. (6.8) that j_0 is related to the positions of the string endpoints. Therefore, we have a contribution to the partition function of the form

$$q^{\frac{1}{2} j_0^2} = \exp \left(-2\pi t \frac{1}{2} \left(\frac{x_0^b - x_0^a}{2\pi} \right)^2 \right) = \exp \left(-\frac{t}{4\pi} (x_0^b - x_0^a)^2 \right).$$

- Finally, for the case of mixed Neumann–Dirichlet boundary conditions, we saw that the Laurent modes j_n take half-integer values for n . We do not present a detailed calculation for this case but recall our discussion of the free boson orbifold from Sect. 4.2.5. There, we encountered the twisted sector where the Laurent modes j_n also took half-integer values for n . From Eq. (4.51), we can then extract $\mathrm{Tr}_{n \in \mathbb{Z} + \frac{1}{2}} \left(q^{L_0 - \frac{c}{24}} \right)$ giving us the partition function in the present case.

In summary, the cylinder partition functions for the example of the free boson read

$$\begin{aligned} \mathcal{Z}_{\mathrm{bos.}}^{\mathcal{C}(\mathrm{D},\mathrm{D})}(t) &= \exp \left(-\frac{t}{4\pi} (x_0^b - x_0^a)^2 \right) \frac{1}{\eta(it)}, \\ \mathcal{Z}_{\mathrm{bos.}}^{\mathcal{C}(\mathrm{N},\mathrm{N})}(t) &= \frac{1}{2\sqrt{t}} \frac{1}{\eta(it)}, \\ \mathcal{Z}_{\mathrm{bos.}}^{\mathcal{C}(\mathrm{mixed})}(t) &= \sqrt{\frac{\eta(it)}{\vartheta_4(it)}}. \end{aligned} \quad (6.11)$$

6.2 Boundary States for the Free Boson

In the last section, we have described the boundaries for the free boson CFT implicitly via the boundary conditions for the fields. However, in an abstract CFT usually there is no Lagrangian formulation available and no boundary terms will arise from

a variational principle. Therefore, to proceed, we need a more inherent formulation of a boundary.

In the following, we first illustrate the construction of the so-called boundary states for the example of the free boson and in the next section, we generalise the structure to Rational conformal field theories with boundaries.

6.2.1 Boundary Conditions

Boundary States

Let us start with the following observation. As it is illustrated in Fig. 6.4, by interchanging τ and σ , we can interpret the cylinder partition function of the boundary conformal field theory on the left-hand side as a tree-level amplitude of the underlying theory shown on the right-hand side. From a string theory point of view, the tree-level amplitude describes the emission of a closed string at boundary A which propagates to boundary B and is absorbed there. Thus, a boundary can be interpreted as an object, which couples to closed strings. Note that in order to simplify our notation, we call the sector of the BCFT *open* and the sector of the underlying CFT *closed*. The relation above then reads

$$(\sigma, \tau)_{\text{open}} \longleftrightarrow (\tau, \sigma)_{\text{closed}}, \quad (6.12)$$

which in string theory is known as the world-sheet duality between open and closed strings.

The boundary for the closed sector can be described by a coherent state in the Hilbert space $\mathcal{H} \otimes \bar{\mathcal{H}}$ which takes the general form

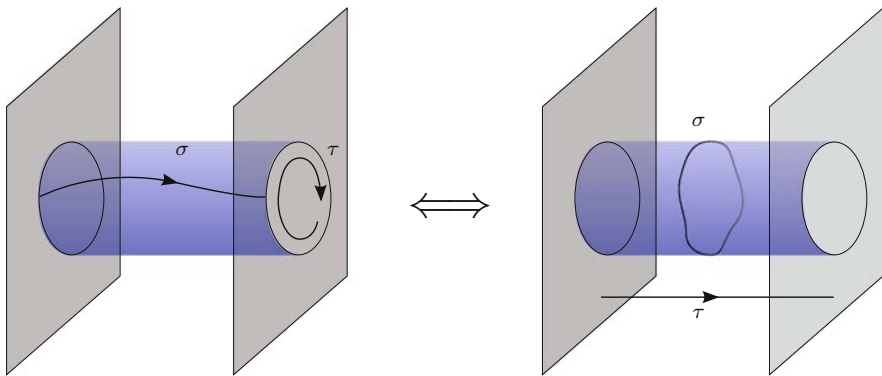

Fig. 6.4 Illustration of world-sheet duality relating the cylinder amplitude in the open and closed sector

$$|B\rangle = \sum_{i, \bar{j} \in \mathcal{H} \otimes \overline{\mathcal{H}}} \alpha_{i\bar{j}} |i, \bar{j}\rangle.$$

Here i, \bar{j} label the states in the holomorphic and anti-holomorphic sector of $\mathcal{H} \otimes \overline{\mathcal{H}}$, and the coefficients $\alpha_{i\bar{j}}$ encode the *strength* of how the closed string mode $|i, \bar{j}\rangle$ couples to the boundary $|B\rangle$. Such a coherent state is called a *boundary state* and provides the CFT description of a D-brane in string theory.

Boundary Conditions

Let us now translate the boundary conditions (6.3) into the picture of boundary states. By using relation (6.12), we readily obtain

$$\boxed{\begin{array}{ll} \partial_\tau X_{\text{closed}}|_{\tau=0} |B_N\rangle = 0 & \text{Neumann condition,} \\ \partial_\sigma X_{\text{closed}}|_{\tau=0} |B_D\rangle = 0 & \text{Dirichlet condition.} \end{array}} \quad (6.13)$$

Next, for the free boson theory we would like to express the boundary conditions (6.13) of a boundary state in terms of the Laurent modes. To do so, we recall Eq. (6.4) and set $\tau = 0$ to obtain

$$\begin{aligned} i \cdot \partial_\tau X_{\text{closed}}|_{\tau=0} &= \sum_{n \in \mathbb{Z}} (j_n e^{-in\sigma} + \bar{j}_n e^{+in\sigma}), \\ \partial_\sigma X_{\text{closed}}|_{\tau=0} &= \sum_{n \in \mathbb{Z}} (j_n e^{-in\sigma} - \bar{j}_n e^{+in\sigma}). \end{aligned} \quad (6.14)$$

We then relabel $n \rightarrow -n$ in the second term of each line and observe again that for generic σ , the summands are linearly independent. Therefore, the boundary conditions (6.13) expressed in terms of the Laurent modes read

$$\boxed{\begin{array}{ll} (j_n + \bar{j}_{-n}) |B_N\rangle = 0, \quad (\pi_0 |B_N\rangle = 0) & \text{Neumann condition,} \\ (j_n - \bar{j}_{-n}) |B_D\rangle = 0 & \text{Dirichlet condition,} \end{array}} \quad (6.15)$$

for each n . Such conditions relating the chiral and anti-chiral modes acting on the boundary state are called *gluing conditions*. Note that for the case of Neumann boundary conditions, in the string theory picture the relation $\pi_0 = 0$ means that there is no momentum transfer through the boundary. On the other hand, for Dirichlet conditions there is no restriction on π_0 .

Solutions to the Gluing Conditions

Next, we are going to state the solutions for the gluing conditions for the example of the free boson and verify them thereafter. For now, let us ignore the constraints on j_0 . We will come back to this issue later.

The boundary states for Neumann and Dirichlet conditions in terms of the Laurent modes j_n and \bar{j}_n read

$$\boxed{\begin{aligned} |B_N\rangle &= \frac{1}{\mathcal{N}_N} \exp\left(-\sum_{k=1}^{\infty} \frac{1}{k} j_{-k} \bar{j}_{-k}\right) |0\rangle && \text{Neumann condition,} \\ |B_D\rangle &= \frac{1}{\mathcal{N}_D} \exp\left(+\sum_{k=1}^{\infty} \frac{1}{k} j_{-k} \bar{j}_{-k}\right) |0\rangle && \text{Dirichlet condition,} \end{aligned}} \quad (6.16)$$

where \mathcal{N}_N and \mathcal{N}_D are normalisation constants to be fixed later. One possibility to verify the boundary states is to straightforwardly evaluate the gluing conditions (6.15) for the solutions (6.16) explicitly. However, in order to highlight the underlying structure, we will take a slightly different approach.

Construction of Boundary States

In the following, we focus on a boundary state with Neumann conditions but comment on the Dirichlet case at the end. To start, we rewrite the Neumann boundary state in Eq. (6.16) as

$$\begin{aligned} |B_N\rangle &= \frac{1}{\mathcal{N}_N} \exp\left(-\sum_{k=1}^{\infty} \frac{1}{k} j_{-k} \bar{j}_{-k}\right) |0\rangle \\ &= \frac{1}{\mathcal{N}_N} \prod_{k=1}^{\infty} \sum_{m=0}^{\infty} \frac{1}{\sqrt{m!}} \left(\frac{j_{-k}}{\sqrt{k}}\right)^m |0\rangle \otimes \frac{1}{\sqrt{m!}} \left(\frac{-\bar{j}_{-k}}{\sqrt{k}}\right)^m |\bar{0}\rangle \\ &= \frac{1}{\mathcal{N}_N} \sum_{m_1=0}^{\infty} \sum_{m_2=0}^{\infty} \dots \prod_{k=1}^{\infty} \frac{1}{\sqrt{m_k!}} \left(\frac{j_{-k}}{\sqrt{k}}\right)^{m_k} |0\rangle \otimes \frac{1}{\sqrt{m_k!}} \left(\frac{-\bar{j}_{-k}}{\sqrt{k}}\right)^{m_k} |\bar{0}\rangle, \end{aligned} \quad (6.17)$$

where we first have written the sum in the exponential as a product and then we expressed the exponential as an infinite series. Next, we note that the following states form a complete orthonormal basis for all states constructed out of the Laurent modes j_{-k} :

$$|\vec{m}\rangle = |m_1, m_2, \dots\rangle = \prod_{k=1}^{\infty} \frac{1}{\sqrt{m_k!}} \left(\frac{j_{-k}}{\sqrt{k}}\right)^{m_k} |0\rangle. \quad (6.18)$$

The orthonormal property can be seen by computing

$$\langle \vec{n} | \vec{m} \rangle = \prod_{k=1}^{\infty} \frac{1}{\sqrt{n_k! m_k!}} \frac{1}{\sqrt{k}^{n_k+m_k}} \langle 0 | j_{+k}^{n_k} j_{-k}^{m_k} | 0 \rangle_k = \prod_{k=1}^{\infty} \delta_{n_k, m_k} ,$$

where we used that

$$\langle 0 | j_{+k}^n j_{-k}^m | 0 \rangle = k n \langle 0 | j_{+k}^{n-1} j_{-k}^{m-1} | 0 \rangle = \delta_{m,n} k^n n! .$$

We now introduce an operator U mapping the chiral Hilbert space to its charge conjugate $U : \mathcal{H} \rightarrow \mathcal{H}^+$ and similarly for the anti-chiral sector. In particular, the action of U reads

$$U j_k U^{-1} = -j_k = -(j_{-k})^\dagger , \quad U \bar{j}_k U^{-1} = -\bar{j}_k = -(\bar{j}_{-k})^\dagger , \quad U c U^{-1} = c^* ,$$

where c is a constant and $*$ denotes complex conjugation. In the present example, the ground state $|0\rangle$ is non-degenerate and is left invariant by U^1 . Knowing these properties, we can show that U is anti-unitary. For this purpose, we expand a general state as $|a\rangle = \sum_{\vec{m}} A_{\vec{m}} |\vec{m}\rangle$ and compute

$$\begin{aligned} U |a\rangle &= \sum_{\vec{m}} U A_{\vec{m}} U^{-1} \prod_{k=1}^{\infty} \frac{1}{\sqrt{m_k!}} \left(\frac{U j_{-k} U^{-1}}{\sqrt{k}} \right)^{m_k} U |0\rangle \\ &= \sum_{\vec{m}} A_{\vec{m}}^* \prod_{k=1}^{\infty} (-1)^{m_k} |\vec{m}\rangle , \end{aligned} \tag{6.19}$$

where \vec{m} denotes the multi-index $\{m_1, m_2, \dots\}$. By using that $|\vec{m}\rangle$ and $|\vec{n}\rangle$ form an orthonormal basis, we can now show that U is anti-unitary

$$\langle Ub | Ua \rangle = \sum_{\vec{n}, \vec{m}} \langle \vec{n} | B_{\vec{n}} \prod_{k=1}^{\infty} (-1)^{n_k+m_k} A_{\vec{m}}^* |\vec{m}\rangle = \sum_{\vec{m}} A_{\vec{m}}^* B_{\vec{m}} = \langle a | b \rangle .$$

After introducing an orthonormal basis and the anti-unitary operator U , we now express Eq. (6.17) in a more general way which will simplify and generalise the following calculations:

$$|B\rangle = \frac{1}{\mathcal{N}} \sum_{\vec{m}} |\vec{m}\rangle \otimes |U \vec{m}\rangle .$$

¹ For degenerate ground states, appearing for instance for CFTs with extended symmetries studied in Chap. 3, a non-trivial action on the ground state might need to be defined.

Verification of the Gluing Conditions

In order to verify the gluing conditions (6.15) for Neumann boundary states, we note that these have to be satisfied also when an arbitrary state $\langle \bar{a} | \otimes \langle b |$ is multiplied from the left. We then calculate

$$\begin{aligned} \langle \bar{a} | \otimes \langle b | j_n + \bar{j}_{-n} | B \rangle &= \frac{1}{\mathcal{N}} \sum_{\vec{m}} \langle \bar{a} | \otimes \langle b | j_n + \bar{j}_{-n} | \vec{m} \rangle \otimes | U \vec{m} \rangle \\ &= \frac{1}{\mathcal{N}} \sum_{\vec{m}} \langle b | j_n | \vec{m} \rangle \langle \bar{a} | U \vec{m} \rangle + \langle b | \vec{m} \rangle \langle \bar{a} | \bar{j}_{-n} | U \vec{m} \rangle. \end{aligned}$$

Next, due to the identifications on the boundary, the holomorphic and the anti-holomorphic algebra are identical. We can therefore replace matrix elements in the anti-holomorphic sector by those in the holomorphic sector. Using finally the anti-unitarity of U and that $\sum_{\vec{m}} |\vec{m}\rangle \langle \vec{m}| = \mathbb{1}$, we find

$$\begin{aligned} \langle \bar{a} | \otimes \langle b | j_n + \bar{j}_{-n} | B \rangle &= \frac{1}{\mathcal{N}} \sum_{\vec{m}} \langle b | j_n | \vec{m} \rangle \langle a | U \vec{m} \rangle + \langle b | \vec{m} \rangle \langle a | j_{-n} | U \vec{m} \rangle \\ &= \frac{1}{\mathcal{N}} \sum_{\vec{m}} \langle b | j_n | \vec{m} \rangle \langle \vec{m} | U^{-1} a \rangle + \langle b | \vec{m} \rangle \langle \vec{m} | (-j_n) | U^{-1} a \rangle \\ &= \frac{1}{\mathcal{N}} \left(\langle b | j_n | U^{-1} a \rangle - \langle b | j_n | U^{-1} a \rangle \right) = 0. \end{aligned}$$

Therefore, we have verified that the Neumann boundary state in Eq. (6.16) is indeed a solution to the corresponding gluing condition in Eq. (6.15).

For the case of Dirichlet boundary conditions, the action of U on the Laurent modes j_n and \bar{j}_n is chosen with a $+$ sign while we still require U to be anti-unitary, i.e. $U c U^{-1} = c^*$. The calculation is then very similar to the Neumann case presented here. Note furthermore, the construction of boundary states and the verification of the gluing conditions are also applicable for more general CFTs, for instance RCFTs, which we will consider in Sect. 6.3.

Momentum Dependence of Boundary States

In Eq. (2.91), we have computed the momentum π_0 in the closed sector which is related to j_0 and \bar{j}_0 as $\pi_0 = j_0 = \bar{j}_0$. This is in contrast to the result in the open sector which we obtained in Eq. (6.6). In the following, the relation between j_0 , \bar{j}_0 and π_0 should be clear from the context, but let us summarise that

$$(\pi_0)_{\text{closed}} = j_0 = \bar{j}_0, \quad (\pi_0)_{\text{open}} = \frac{1}{2} j_0 = \frac{1}{2} \bar{j}_0. \quad (6.20)$$

From a string theory point of view, in addition to the boundary conditions (6.15) there is a further natural constraint on a boundary state with Dirichlet conditions. Namely, the closed string at time $\tau = 0$ is located at the boundary at position x_0^a . We therefore impose

$$X_{\text{closed}}(\tau = 0, \sigma) |B_D\rangle = x_0^a |B_D\rangle$$

and similarly for $\tau = \pi$. An easy way to realise this constraint is to perform a Fourier transformation from momentum space $|B_D, \pi_0\rangle$ to the position space. Concretely, this reads

$$|B_D, x_0^a\rangle = \int d\pi_0 e^{i\pi_0 x_0^a} |B_D, \pi_0\rangle.$$

For the boundary state with Neumann conditions, we have $\pi_0 = 0$ and in position space, there is no definite value for x_0 . We thus omit this label.

Conformal Symmetry

In studying the example of the free boson, we have expressed all important quantities in terms of the $U(1)$ current modes j_n and \bar{j}_n . However, in more general CFTs such additional symmetries may not be present but the conformal symmetry generated by the energy–momentum tensors always is. In view of generalisations of our present example, let us therefore determine the boundary conditions of the boundary states in terms of the Laurent modes L_n and \bar{L}_n .

Mainly guided by the final result, let us compute the following expression by employing that $T(z) = \frac{1}{2}N(jj)(z)$ which implies $L_n = \frac{1}{2}\sum_{k>-1} j_{n-k}j_k + \frac{1}{2}\sum_{k\leq-1} \bar{j}_k\bar{j}_{n-k}$:

$$\begin{aligned} & (L_n - \bar{L}_{-n}) |B_{N,D}\rangle \\ &= \frac{1}{2} \left(\sum_{k>-1} (j_{n-k}j_k - \bar{j}_{-n-k}\bar{j}_k) + \sum_{k\leq-1} (j_kj_{n-k} - \bar{j}_k\bar{j}_{-n-k}) \right) |B_{N,D}\rangle \\ &= \frac{1}{2} \left(j_nj_0 - \bar{j}_{-n}\bar{j}_0 + \sum_{k\geq 1} (j_{n-k}j_k - \bar{j}_{-n-k}\bar{j}_k + j_{-k}j_{n+k} - \bar{j}_{-k}\bar{j}_{-n+k}) \right) |B_{N,D}\rangle. \end{aligned}$$

Note that here we changed the summation index $k \rightarrow -k$ in the second sum. Next, we recall Eq. (6.15) and $j_0 = \bar{j}_0$ to observe that the terms involving j_0 and \bar{j}_0 vanish when applied to $|B_{N,D}\rangle$. The remaining terms can be rewritten as

$$\begin{aligned} & \frac{1}{2} \sum_{k\geq 1} \left(j_{n-k}(j_k \pm \bar{j}_{-k}) \mp j_{n-k}\bar{j}_{-k} \mp \bar{j}_{-n-k}(j_{-k} \pm \bar{j}_k) \pm \bar{j}_{-n-k}j_{-k} \right. \\ & \quad \left. + j_{-k}(j_{n+k} \pm \bar{j}_{-n-k}) \mp j_{-k}\bar{j}_{-n-k} \mp \bar{j}_{-k}(j_{n-k} \pm \bar{j}_{-n+k}) \pm \bar{j}_{-k}j_{n-k} \right) |B_{N,D}\rangle. \end{aligned}$$

By again employing the boundary conditions (6.15), we see that half of these terms vanish when acting on the boundary state, while the other half cancels among themselves. In summary, we have shown that

$$(L_n - \bar{L}_{-n}) |B_{N,D}\rangle = 0 .$$

6.2.2 Tree-Level Amplitudes

Cylinder Diagram in General

We now turn to the cylinder diagram which we compute in the closed sector. Referring again to Fig. 6.4, in string theory, we can interpret this diagram as a closed string which is emitted at the boundary A , propagating via the closed sector Hamiltonian $H_{\text{closed}} = L_0 + \bar{L}_0 - \frac{c+\bar{c}}{24}$ for a time $\tau = l$ until it reaches the boundary B where it gets absorbed. In analogy to Quantum Mechanics, such an amplitude is given by the overlap

$$\tilde{\mathcal{Z}}^{\mathcal{C}}(l) = \langle \Theta B | e^{-2\pi l (L_0 + \bar{L}_0 - \frac{c+\bar{c}}{24})} | B \rangle , \quad (6.21)$$

where the tilde indicates that the computation is performed in the closed sector (or at tree-level) and l is the length of the cylinder connecting the two boundaries.

Let us now explain the notation $\langle \Theta B |$. This bra-vector is understood in the sense of Sect. 2.8 as the hermitian conjugate of the ket-vector $|\Theta B\rangle$. Furthermore, we have introduced the CPT operator Θ which acts as charge conjugation (C) defined in (4.31), parity transformation (P) $\sigma \mapsto -\sigma$ and time reversal (T) $\tau \mapsto -\tau$ for the two-dimensional CFT. The reason for considering this operator can roughly be explained by the fact that the orientation of the boundary a closed string is emitted at is opposite to the orientation of the boundary where the closed string gets absorbed. For the momentum dependence of a boundary state $|B, \pi_0\rangle$, this implies in particular that

$$\langle \pi_0^a | \pi_0^b \rangle = \delta(\pi_0^a + \pi_0^b) . \quad (6.22)$$

Without a detailed derivation, we finally note that the theory of the free boson is CPT invariant and so the action of Θ on the boundary states (6.16) of the free boson theory (and on ordinary numbers $c \in \mathbb{C}$) reads

$$\Theta |B, \pi_0\rangle = \frac{1}{\mathcal{N}^*} |B, \pi_0\rangle , \quad \Theta c \Theta^{-1} = c^* , \quad (6.23)$$

where $*$ denotes complex conjugation.

Free Boson II : Cylinder Diagram (Tree-Channel)

Let us now be more concrete and compute the overlap of two boundary states (6.21) for the example of the free boson. To do so, we note that for the free boson CFT we have $c = \bar{c} = 1$ and we recall from Sect. 4.2.1 that

$$L_0 = \frac{1}{2} j_0 j_0 + \sum_{k \geq 1} j_{-k} j_k ,$$

and similarly for \bar{L}_0 . Next, we perform the following calculation in order to evaluate Eq. (6.21). In particular, we use $j_{-k} j_k j_{-k}^{m_k} |0\rangle = m_k k j_{-k}^{m_k} |0\rangle$ which we obtained from Eq. (4.13) to find

$$\begin{aligned} q^{\sum_{k \geq 1} j_{-k} j_k} |\vec{m}\rangle &= \prod_{k=1}^{\infty} \sum_{p=0}^{\infty} \frac{(-2\pi i \tau)^p}{p!} (j_{-k} j_k)^p \prod_{l=1}^{\infty} \frac{1}{\sqrt{m_l!}} \left(\frac{j_{-l}}{\sqrt{l}} \right)^{m_l} |0\rangle \\ &= \prod_{k=1}^{\infty} \sum_{p=0}^{\infty} \frac{(-2\pi i \tau)^p}{p!} (m_k k)^p \prod_{l=1}^{\infty} \frac{1}{\sqrt{m_l!}} \left(\frac{j_{-l}}{\sqrt{l}} \right)^{m_l} |0\rangle \quad (6.24) \\ &= \prod_{k=1}^{\infty} q^{m_k k} |\vec{m}\rangle . \end{aligned}$$

The cylinder diagram for the three possible combinations of boundary conditions is then computed as follows.

- For the case of Neumann–Neumann boundary conditions, we have $j_0 |B_N\rangle = \bar{j}_0 |B_N\rangle = 0$ and so the momentum contribution vanishes. For the remaining part, we calculate using Eqs. (6.24) and (6.19)

$$\begin{aligned} \tilde{Z}_{\text{bos.}}^{\mathcal{C}(\text{N,N})}(l) &= \frac{e^{-2\pi l(-\frac{2}{24})}}{\mathcal{N}_N^2} \sum_{\vec{m}} \langle \vec{m} | e^{-2\pi l \sum_{k \geq 1} j_{-k} j_k} | \vec{m} \rangle \times \\ &\quad \times \langle U \vec{m} | e^{-2\pi l \sum_{k \geq 1} \bar{j}_{-k} \bar{j}_k} | U \vec{m} \rangle \\ &= \frac{e^{-2\pi l(-\frac{2}{24})}}{\mathcal{N}_N^2} \sum_{\vec{m}} \prod_{k=1}^{\infty} e^{-2\pi l m_k k} (-1)^{\sum_{i=1}^{\infty} m_i} e^{-2\pi l m_k k} (-1)^{\sum_{i=1}^{\infty} m_i} \\ &= \frac{e^{\frac{\pi l}{6}}}{\mathcal{N}_N^2} \prod_{k=1}^{\infty} \sum_{m_k=0}^{\infty} \left(e^{-4\pi l k} \right)^{m_k} = \frac{1}{\mathcal{N}_N^2} e^{\frac{\pi l}{6}} \prod_{k=1}^{\infty} \frac{1}{1 - e^{-4\pi l k}} , \end{aligned}$$

where in the last step, we performed a summation of the geometric series. Let us emphasise that due to the action of the CPT operator Θ shown in Eq. (6.23), \mathcal{N}^2 is just the square of \mathcal{N} and not the absolute value squared. Then, with $q = e^{2\pi i \tau}$, $\tau = 2il$ and $\eta(\tau)$ the Dedekind η -function defined in Sect. 4.2.1, we find that the cylinder diagram for Neumann–Neumann boundary conditions is expressed as

$$\tilde{\mathcal{Z}}_{\text{bos.}}^{\mathcal{C}(\text{N,N})}(l) = \frac{1}{\mathcal{N}_{\text{N}}^2} \frac{1}{\eta(2il)}. \tag{6.25}$$

- Next, we consider the case of Dirichlet–Dirichlet boundary conditions. Noting that U now acts trivially on the basis states, we see that apart from the momentum contribution the calculation is similar to the case with Neumann–Neumann conditions. However, for the momentum dependence, we compute using Eqs. (6.22) and (6.23)

$$\begin{aligned} & \int_{-\infty}^{\infty} d\pi_0^a d\pi_0^b e^{+ix_0^a \pi_0^a} e^{+ix_0^b \pi_0^b} \langle \pi_0^a | e^{-2\pi l(j_0)^2} | \pi_0^b \rangle \\ &= \int_{-\infty}^{\infty} d\pi_0^a d\pi_0^b e^{+ix_0^a \pi_0^a} e^{+ix_0^b \pi_0^b} e^{-2\pi l(\pi_0^b)^2} \delta(\pi_0^a + \pi_0^b) \\ &= \int_{-\infty}^{\infty} d\pi_0^a e^{-2\pi l \left(\pi_0^a + i \frac{x_0^b - x_0^a}{4\pi l} \right)^2} e^{-\frac{(x_0^b - x_0^a)^2}{8\pi l}} = \frac{1}{\sqrt{2l}} e^{-\frac{(x_0^b - x_0^a)^2}{8\pi l}}, \end{aligned}$$

where we completed a perfect square and performed the Gaussian integration. In order to arrive at the result above, we also employed that in the closed sector $\pi_0 = j_0 = \bar{j}_0$. The cylinder diagram with Dirichlet–Dirichlet boundary conditions therefore reads

$$\tilde{\mathcal{Z}}_{\text{bos.}}^{\mathcal{C}(\text{D,D})}(l) = \frac{1}{\mathcal{N}_{\text{D}}^2} \exp\left(-\frac{(x_0^b - x_0^a)^2}{8\pi l}\right) \frac{1}{\sqrt{2l}} \frac{1}{\eta(2il)}.$$

- Finally, for mixed Neumann–Dirichlet conditions, the boundary state satisfies $j_0|B_{\text{D}}\rangle = \bar{j}_0|B_{\text{D}}\rangle = \pi_0|B_{\text{D}}\rangle$ which leads us to

$$\int d\pi_0 e^{i\pi_0 x_0} \langle \pi_0 = 0 | e^{-2\pi l j_0^2} | \pi_0 \rangle = \int d\pi_0 e^{i\pi_0 x_0} e^{-2\pi l \pi_0^2} \delta(\pi_0) = 1.$$

In the anti-holomorphic sector of the Dirichlet boundary state, the action of U on the basis states $|\bar{m}\rangle$ is trivial and so we obtain a single factor of $(-1)^{\sum_k m_k}$. For the full cylinder diagram, this implies

$$\tilde{\mathcal{Z}}_{\text{bos.}}^{\mathcal{C}(\text{mixed})}(l) = \frac{e^{\frac{\pi l}{6}}}{\mathcal{N}_{\text{N}} \mathcal{N}_{\text{D}}} \prod_{k=1}^{\infty} \sum_{m_k=0}^{\infty} \left(-e^{-4\pi l k}\right)^{m_k} = \frac{e^{\frac{\pi l}{6}}}{\mathcal{N}_{\text{N}} \mathcal{N}_{\text{D}}} \prod_{k=1}^{\infty} \frac{1}{1 + e^{-4\pi l k}}.$$

Recalling then the definitions of ϑ -functions from p. 137, we see that we can express the cylinder diagram for mixed boundary conditions as

$$\tilde{\mathcal{Z}}_{\text{bos.}}^{\mathcal{C}(\text{mixed})}(l) = \frac{\sqrt{2}}{\mathcal{N}_{\text{N}} \mathcal{N}_{\text{D}}} \sqrt{\frac{\eta(2il)}{\vartheta_2(2il)}}.$$

Loop-Channel – Tree-Channel Equivalence

Let us come back to Fig. 6.4. As it is illustrated there and motivated at the beginning of this section, we expect the cylinder diagram in the closed and open sectors to be related. More specifically, this relation is established by $(\sigma, \tau)_{\text{open}} \leftrightarrow (\tau, \sigma)_{\text{closed}}$, where σ is the world-sheet space coordinate and τ is world-sheet time. However, this mapping does not change the cylinder, in particular, it does not change the modular parameter τ . In the open sector, the cylinder has length $\frac{1}{2}$ and circumference t when measured in units of 2π , while in the closed sector we have length l and circumference 1. Referring then to Eq. (4.6) in Chap. 4, we find for the modular parameter in the open and closed sectors that

$$\tau_{\text{open}} = \frac{\alpha_2}{\alpha_1} = \frac{it}{1/2} = 2it, \quad \tau_{\text{closed}} = \frac{\alpha_2}{\alpha_1} = \frac{i}{l}.$$

As we have emphasised, the modular parameters in the open and closed sectors have to be equal which leads us to the relation

$$t = \frac{1}{2l}.$$

This is the formal expression for the pictorial *loop-channel–tree-channel equivalence* of the cylinder diagram illustrated in Fig. 6.4.

We now verify this relation for the example of the free boson explicitly which will allow us to fix the normalisation constants \mathcal{N}_D and \mathcal{N}_N of the boundary states. Recalling the cylinder partition function (6.11) in the open sector, we compute

$$\mathcal{Z}_{\text{bos.}}^{C(N,N)}(t) = \frac{1}{2\sqrt{t}} \frac{1}{\eta(it)} \xrightarrow{t=\frac{1}{2l}} \sqrt{\frac{l}{2}} \frac{1}{\eta(-\frac{1}{2il})} = \frac{1}{2\eta(2il)} = \frac{\mathcal{N}_N^2}{2} \tilde{\mathcal{Z}}_{\text{bos.}}^{C(N,N)}(l),$$

where we used the modular properties of the Dedekind η function summarised in Eq. (4.15). Therefore, requiring the results in the loop- and tree-channels to be related, we can fix

$$\mathcal{N}_N = \sqrt{2}. \tag{6.26}$$

Next, for Dirichlet–Dirichlet boundary conditions, we find

$$\begin{aligned} \mathcal{Z}_{\text{bos.}}^{C(D,D)}(t) &= \exp\left(-\frac{t}{4\pi}(x_0^b - x_0^a)^2\right) \frac{1}{\eta(it)} \\ &\xrightarrow{t=\frac{1}{2l}} \exp\left(-\frac{1}{8\pi l}(x_0^b - x_0^a)^2\right) \frac{1}{\eta(-\frac{1}{2il})} = \mathcal{N}_D^2 \tilde{\mathcal{Z}}_{\text{bos.}}^{C(D,D)}(l), \end{aligned}$$

which allows us to fix the normalisation constant as

$$\boxed{\mathcal{N}_D = 1} .$$

Finally, the loop-channel–tree-channel equivalence for mixed Neumann–Dirichlet boundary conditions can be verified along similar lines. This discussion shows that indeed the cylinder partition function for the free boson in the open and closed sectors is related via a modular transformation, more concretely via a modular S -transformation.

Summary and Remark

Let us now briefly summarise our findings of this section and close with some remarks.

- By performing the so-called world-sheet duality $(\sigma, \tau)_{\text{open}} \leftrightarrow (\tau, \sigma)_{\text{closed}}$, we translated the Neumann and Dirichlet boundary conditions from the open sector to the closed sector. In string theory, the boundary in the closed sector is interpreted as an object which absorbs or emits closed strings.
- Working out the boundary conditions in terms of the Laurent modes of the free boson theory, we obtained the gluing conditions

$$(j_n \pm \bar{j}_{-n})|B_{N,D}\rangle = 0 ,$$

which imply that the two $U(1)$ symmetries generated by $j(z)$ and $\bar{j}(\bar{z})$ are broken to a diagonal $U(1)$.

- For the example of the free boson theory, we stated the solution $|B\rangle$ to the gluing conditions and verified them. Along the way, we also outlined the idea for constructing boundary states for more general theories.
- The cylinder amplitude in the closed sector (tree-level) is computed from the overlap of two boundary states

$$\tilde{\mathcal{Z}}^c(l) = \langle \Theta B | e^{-2\pi l(L_0 + \bar{L}_0 - \frac{c+\bar{c}}{24})} | B \rangle .$$

We performed this calculation for the free boson and checked that it is related to the cylinder partition function in the open sector via world-sheet duality. In particular, this transformation is a modular S -transformation.

- Finally, the BCFT also has to preserve the conformal symmetry generated by $T(z)$. The boundary states respect this symmetry in the sense that the following conditions have to be satisfied:

$$(L_n - \bar{L}_{-n})|B_{N,D}\rangle = 0 ,$$

which we checked for the example of the free boson theory.

- Very similarly, one can generalise the concept of boundaries and boundary states to the CFT of a free fermion which is very important for applications in Superstring Theory.

As we mentioned already, in string theory boundary states are called D-branes to emphasise the space–time point of view of such objects. They are higher dimensional generalisations of strings and membranes, and indeed they play a very important role in understanding the non-perturbative sector of string theory. It was one of the big insights at the end of the last millennium that such higher dimensional objects are naturally contained in string theory (which started as a theory of only one-dimensional objects) and gave rise to various surprising dualities, the most famous surely being the celebrated AdS/CFT correspondence.

6.3 Boundary States for RCFTs

After having studied the Boundary CFT of the free boson in great detail, let us now generalise our findings to theories without a Lagrangian description. In particular, we focus on RCFTs and we will formulate the corresponding Boundary RCFT just in terms of gluing conditions for the theory on the sphere.

Boundary Conditions

We consider Rational conformal field theories with chiral and anti-chiral symmetry algebras \mathcal{A} and $\overline{\mathcal{A}}$, respectively. As we have seen in Chap. 2, for the theory on the sphere the Hilbert space splits into irreducible representations of $\mathcal{A} \otimes \overline{\mathcal{A}}$ as

$$\mathcal{H} = \bigoplus_{i, \bar{j}} M_{i\bar{j}} \mathcal{H}_i \otimes \overline{\mathcal{H}}_{\bar{j}},$$

where $M_{i\bar{j}}$ are the same multiplicities of the highest weight representation appearing in the modular invariant torus partition function. Note that for the case of RCFTs we are considering, there is only a finite number of irreducible representations and that the modular invariant torus partition function is given by a combination of chiral and anti-chiral characters as follows (4.61):

$$\mathcal{Z}(\tau, \bar{\tau}) = \sum_{i, \bar{j}} M_{i\bar{j}} \chi_i(\tau) \overline{\chi}_{\bar{j}}(\bar{\tau}).$$

Generalising the results from the free boson theory, we state without derivation that a boundary state $|B\rangle$ in the RCFT preserving the symmetry algebra $\mathcal{A} = \overline{\mathcal{A}}$ has to satisfy the following gluing conditions:

$$\begin{array}{ll}
 (L_n - \bar{L}_{-n})|B\rangle = 0 & \text{conformal symmetry,} \\
 (W_n^i - (-1)^{h^i} \bar{W}_{-n}^i)|B\rangle = 0 & \text{extended symmetries,}
 \end{array}
 \tag{6.27}$$

where W_n^i is the holomorphic Laurent mode of the extended symmetry generator W^i with conformal weight $h^i = h(W^i)$, and \bar{W}^i denotes the generator in the anti-holomorphic sector. However, the condition for the extended symmetries can be relaxed, so that also Dirichlet boundary conditions similar to the example of a free boson are included

$$(W_n^i - (-1)^{h^i} \Omega(\bar{W}_{-n}^i))|B\rangle = 0,$$

where $\Omega : \mathcal{A} \rightarrow \mathcal{A}$ is an automorphism of the chiral algebra \mathcal{A} . Such an automorphism Ω is also called a *gluing automorphism* and for our example of the free boson with Dirichlet boundary conditions, it simply is $\Omega : \bar{j}_n \mapsto -\bar{j}_n$.

Ishibashi States

Next, let us recall from (4.31) that the charge conjugation matrix C maps highest weight representations i to their charge conjugate i^+ . Denoting then the Hilbert space built upon the charge conjugate representation by \mathcal{H}_i^+ , we can state the important result of Ishibashi:

For $\bar{\mathcal{A}} = \mathcal{A}$ and $\bar{\mathcal{H}}_i = \mathcal{H}_i^+$, to each highest weight representation ϕ_i of \mathcal{A} one can associate an up to a constant unique state $|\mathcal{B}_i\rangle\rangle$ such that the gluing conditions are satisfied.

Note that since the CFTs we are considering are rational, there is only a finite number of highest weight states and thus only a finite number of such so-called Ishibashi states $|\mathcal{B}_i\rangle\rangle$.

We now construct the Ishibashi states in analogy to the boundary states of the free boson. Denoting by $|\phi_i, \vec{m}\rangle$ an orthonormal basis for \mathcal{H}_i , the Ishibashi states are written as

$$|\mathcal{B}_i\rangle\rangle = \sum_{\vec{m}} |\phi_i, \vec{m}\rangle \otimes U |\bar{\phi}_i, \vec{m}\rangle, \tag{6.28}$$

where $U : \bar{\mathcal{H}} \rightarrow \bar{\mathcal{H}}^+$ is an anti-unitary operator acting on the symmetry generators \bar{W}^i as follows:

$$U \bar{W}_n^i U^{-1} = (-1)^{h^i} (\bar{W}_{-n}^i)^\dagger.$$

The proof that the Ishibashi states are solutions to the gluing conditions (6.27) is completely analogous to the example of the free boson and so we will not present it here.

The Cardy Condition

For later purpose, let us now compute the following overlap of two Ishibashi states:

$$\langle\langle \mathcal{B}_j | e^{-2\pi l (L_0 + \bar{L}_0 - \frac{c+\bar{c}}{24})} | \mathcal{B}_i \rangle\rangle. \quad (6.29)$$

Utilising the gluing conditions for the conformal symmetry generator (6.27), we see that we can replace \bar{L}_0 by L_0 and \bar{c} by c . Next, because the Hilbert spaces of two different HWRs ϕ_i and ϕ_j are independent of each other, the overlap above is only nonzero for $i = j^+$. Note that here we have written the charge conjugate j^+ of the highest weight ϕ_j because the hermitian conjugation also acts as charge conjugation. We then obtain

$$\begin{aligned} \langle\langle \mathcal{B}_j | e^{-2\pi l (L_0 + \bar{L}_0 - \frac{c+\bar{c}}{24})} | \mathcal{B}_i \rangle\rangle &= \delta_{ij^+} \langle\langle \mathcal{B}_i | e^{2\pi i (2il) (L_0 - \frac{c}{24})} | \mathcal{B}_i \rangle\rangle \\ &= \delta_{ij^+} \text{Tr}_{\mathcal{H}_i} \left(q^{L_0 - \frac{c}{24}} \right) \\ &= \delta_{ij^+} \chi_i(2il), \end{aligned} \quad (6.30)$$

with χ_i the character of the highest weight ϕ_i defined on p. 127. Performing a modular S -transformation for this overlap, by the same reasoning as for the free boson, we expect to obtain a partition function in the boundary sector. However, because the S -transform of a character $\chi_i(2il)$ in general does not give non-negative integer coefficients in the loop-channel, it is not clear whether to interpret such a quantity as a partition function counting states of a given excitation level.

As it turns out, the Ishibashi states are not the boundary states itself but only building blocks guaranteed to satisfy the gluing conditions. A true boundary state in general can be expressed as a linear combination of Ishibashi states in the following way:

$$|B_\alpha\rangle = \sum_i B_\alpha^i | \mathcal{B}_i \rangle. \quad (6.31)$$

The complex coefficients B_α^i in Eq. (6.31) are called reflection coefficients and are very constrained by the so-called Cardy condition. This condition essentially ensures the loop-channel–tree-channel equivalence. Indeed, using relation (6.30) and choosing normalisations such that the action of the CPT operator Θ introduced in Eq. (6.23) reads

$$\Theta |B_\alpha\rangle = \sum_i (B_\alpha^i)^* | \mathcal{B}_{i^+} \rangle, \quad (6.32)$$

the cylinder amplitude between two boundary states of the form (6.31) can be expressed as follows:

$$\begin{aligned}\tilde{\mathcal{Z}}_{\alpha\beta}(l) &= \langle \Theta B_\alpha | e^{-2\pi l (L_0 + \bar{L}_0 - \frac{c+\bar{c}}{24})} | B_\beta \rangle \\ &= \sum_{i,j} B_\alpha^j B_\beta^i \langle\langle B_{j^+} | e^{-2\pi l (L_0 + \bar{L}_0 - \frac{c+\bar{c}}{24})} | B_i \rangle\rangle \\ &= \sum_i B_\alpha^i B_\beta^i \chi_i(2il) .\end{aligned}$$

Performing a modular S -transformation $l \mapsto \frac{1}{2l}$ on the characters χ_i , this closed sector cylinder diagram is transformed to the following expression in the open sector:

$$\tilde{\mathcal{Z}}_{\alpha\beta}(l) \rightarrow \tilde{\mathcal{Z}}_{\alpha\beta}\left(\frac{1}{2l}\right) = \sum_{i,j} B_\alpha^i B_\beta^j S_{ij} \chi_j(it) = \sum_j n_{\alpha\beta}^j \chi_j(it) = \mathcal{Z}_{\alpha\beta}(t) ,$$

where S_{ij} is the modular S -matrix and where we introduced the new coefficients $n_{\alpha\beta}^j$. Now, the Cardy condition is the requirement that this expression can be interpreted as a partition function in the open sector. That is, for all pairs of boundary states $|B_\alpha\rangle$ and $|B_\beta\rangle$ in a RCFT, the following combinations have to be non-negative integers:

$$\boxed{n_{\alpha\beta}^j = \sum_i B_\alpha^i B_\beta^i S_{ij} \in \mathbb{Z}_0^+} .$$

Construction of Boundary States

The Cardy condition just illustrated is very reminiscent of the Verlinde formula, where a similar combination of complex numbers leads to non-negative fusion rule coefficients. For the case of a *charge conjugate* modular invariant partition function, that is, when the characters $\chi_i(\tau)$ are combined with $\bar{\chi}_{i^+}(\bar{\tau})$ as $\mathcal{Z} = \sum_i \chi_i(\tau) \bar{\chi}_{i^+}(\bar{\tau})$, we can construct a generic solution to the Cardy condition by choosing the reflection coefficients in the following way:

$$\boxed{B_\alpha^i = \frac{S_{\alpha i}}{\sqrt{S_{0i}}} .}$$

Note, for each highest weight representation ϕ_i in the RCFT, there exists not only an Ishibashi state but also a boundary state, i.e. the index α in $|B_\alpha\rangle$ also runs from one to the number of HWRs. Employing then the Verlinde formula (4.55) and denoting the non-negative, integer fusion coefficients by $N_{j\beta}^\alpha$, we find that the Cardy condition for the coefficients $n_{\alpha\beta}^j$ is always satisfied

$$n_{\alpha\beta}^j = \sum_i \frac{S_{\alpha i} S_{\beta i} S_{ij}}{S_{0i}} = \sum_i \frac{S_{\alpha i} S_{\beta i} S_{ij}^*}{S_{0i}} = N_{\alpha\beta}^{j+} \in \mathbb{Z}_0^+.$$

Note that here we employed $S_{ij}^* = S_{ij+}$ which is verified by noting that $S^{-1} = S^*$ as well as that $S^2 = C$ with C the charge conjugation matrix $C_{ij} = \delta_{ij+}$ introduced in (4.31).

Remark

For more general modular invariant partition functions, it is still an active area of research to construct the boundary states. Again the concept of simple currents is very helpful to find new solutions.

Without proof, we state one important result. If J is an orbit simple current of length L in a RCFT with charge conjugate modular invariant partition function, then the orbits of boundary states

$$|B_\alpha^J\rangle = \sum_{k=0}^{L-1} |J^k B_\alpha\rangle$$

of the original RCFT define new boundary states for the simple current extension. In this manner, one can construct boundary states for Gepner models which, as presented in Sect. 5.6, are simple current extensions of certain tensor products of $\mathcal{N} = 2$ SCFTs. For further simple current extensions of Gepner models, these techniques are also applicable and lead to a plethora of boundary states of Gepner models.

6.4 CFTs on Non-Orientable Surfaces

Up to this point, we have studied conformal field theories defined on the Riemann sphere and the complex plane, respectively and on the torus. For Boundary CFTs, the corresponding surfaces are the upper half-plane and the cylinder. We note that all these surfaces are orientable, that is, an orientation can be chosen globally.

However, in string theory, it is necessary to also define CFTs on non-orientable surfaces. One such surface is the so-called crosscap $\mathbb{R}P^2$ which can be viewed as a two-sphere with opposite points identified. Other non-orientable surfaces are the Möbius strip and the Klein bottle, and a summary of all surfaces relevant for the following is shown in Fig. 6.5.

Orientifolds

Before formulating CFTs on non-orientable surfaces, let us briefly explain the string theory origin of such theories. Recalling the action for a free boson (6.1), we observe that this theory has a discrete symmetry denoted as Ω which takes the form

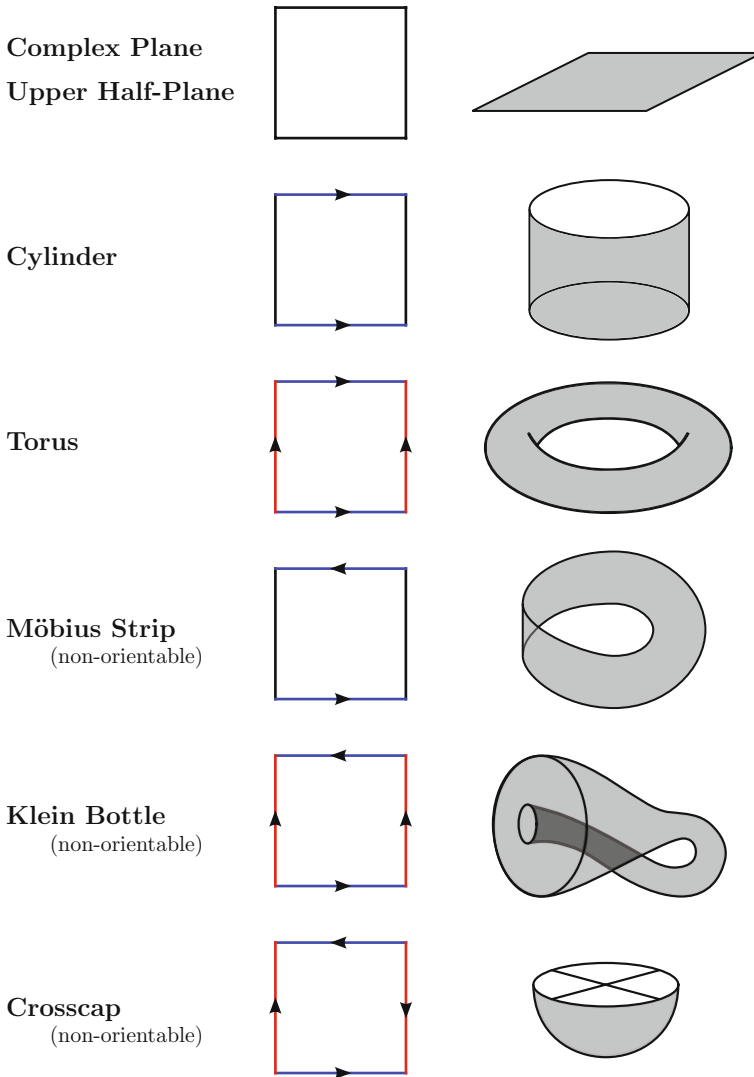

Fig. 6.5 Two-dimensional orientable and non-orientable surfaces. On the *left-hand side*, the fundamental domain can be found and it is indicated how opposite edges are identified leading to the surfaces illustrated on the *right-hand side*. Note that for the identification of opposite edges the orientation given by the *arrows* is crucial

$$\Omega : X(\tau, \sigma) \mapsto \tilde{X}(\tau, \sigma) = X(\tau, -\sigma) , \tag{6.33}$$

with τ and σ again world-sheet time and space coordinates. To see that the action (6.1) is invariant under Ω , observe that

$$\begin{aligned}\Omega(\partial_\sigma X)(\tau, \sigma)\Omega^{-1} &= -(\partial_\sigma X)(\tau, -\sigma), \\ \Omega(\partial_\tau X)(\tau, \sigma)\Omega^{-1} &= +(\partial_\tau X)(\tau, -\sigma).\end{aligned}\tag{6.34}$$

Next, let us note that from the mapping (6.33), we see that Ω acts as a world-sheet parity operator. In the string theory picture, this means that Ω changes the orientation of a closed string. As with any other symmetry, we can study the quotient of the original theory by the symmetry. We have already considered a quotient CFT in Sect. 4.2.5, where we studied a \mathbb{Z}_2 -orbifold of the free boson compactified on a circle. Since Ω changes orientation, in analogy to orbifolds, such a quotient is called an *orientifold*.

The Example of the Free Boson in More Detail

Let us further elaborate on the action of the orientifold projection Ω for the free boson. We first note that $-\sigma$ has to be interpreted properly because we normalised the world-sheet space coordinate as $\sigma \in [0, 2\pi)$ for the closed sector and as $\sigma \in [0, \pi]$ in the open sector. The correct identification for $-\sigma$ then reads

$$-\sigma_{\text{closed}} \sim 2\pi - \sigma_{\text{closed}}, \quad -\sigma_{\text{open}} \sim \pi - \sigma_{\text{open}}.$$

Next, we consider the free boson in the closed sector and express $\partial_\sigma X$ in Eq. (6.34) in terms of the Laurent modes j_n and \bar{j}_n using Eq. (6.4)

$$\begin{aligned}\Omega(\partial_\sigma X)(\tau, \sigma)\Omega^{-1} &= -(\partial_\sigma X)(\tau, -\sigma) \\ \sum_{n \in \mathbb{Z}} \left(\Omega j_n \Omega^{-1} e^{-n(\tau+i\sigma)} - \Omega \bar{j}_n \Omega^{-1} e^{-n(\tau-i\sigma)} \right) \\ &= \sum_{n \in \mathbb{Z}} \left(-j_n e^{-n(\tau+i(2\pi-\sigma))} + \bar{j}_n e^{-n(\tau-i(2\pi-\sigma))} \right).\end{aligned}\tag{6.35}$$

From this relation, we can determine the action of Ω on the modes in the closed sector as follows:

$$\boxed{\Omega j_n \Omega^{-1} = \bar{j}_n, \quad \Omega \bar{j}_n \Omega^{-1} = j_n.}\tag{6.36}$$

For the open sector, we have to replace 2π on the right-hand side in Eq. (6.35) by π which leads to an additional factor of $(-1)^n$. Using then the boundary conditions of an open string (6.5) which relate the Laurent modes as $j_n = \pm \bar{j}_n$, we obtain the action of Ω in the open sector as

$$\boxed{\Omega j_n \Omega^{-1} = \pm(-1)^n j_n,}\tag{6.37}$$

where the two signs correspond to Neumann–Neumann, and Dirichlet–Dirichlet boundary conditions, respectively. For the case of mixed boundary conditions, we recall that the Laurent modes have labels $n \in \mathbb{Z} + \frac{1}{2}$ and we note that Ω interchanges the endpoints of an open string as well as the boundary conditions. In particular, we find

$$\Omega j_n^{(N,D)} \Omega^{-1} = -(-1)^n j_n^{(D,N)}, \quad \Omega j_n^{(D,N)} \Omega^{-1} = +(-1)^n j_n^{(N,D)}. \quad (6.38)$$

Partition Function: Klein Bottle

Let us now consider partition functions for general orientifold theories. We start with the usual form of a modular invariant partition function in a CFT

$$\mathcal{Z}(\tau, \bar{\tau}) = \text{Tr}_{\mathcal{H} \times \bar{\mathcal{H}}} \left(q^{L_0 - \frac{c}{24}} \bar{q}^{\bar{L}_0 - \frac{c}{24}} \right), \quad (6.39)$$

where we indicated the trace over the combined Hilbert space $\mathcal{H} \times \bar{\mathcal{H}}$ explicitly. Next, we generalise our findings from the example of the free boson and define the action of the world-sheet parity operator Ω on the Hilbert space as follows:

$$\Omega |i, \bar{j}\rangle = \pm |\Omega(j), \overline{\Omega(i)}\rangle, \quad (6.40)$$

where i denotes a state in the holomorphic sector of the theory and \bar{j} stands for the anti-holomorphic sector. The two different signs originate from the two possibilities of Ω acting on the vacuum $|0\rangle$ compatible with the requirement that $\Omega^2 = \mathbb{1}$. The simplest choice for $\Omega(i)$ is $\Omega(i) = i$, but also more general \mathbb{Z}_2 involutions are possible, for instance $\Omega(i) = i^+$, where $+$ denotes charge conjugation introduced in (4.31).

Since orientifold constructions are very similar to orbifolds, we can employ the same techniques already introduced in Sect. 4.2.5 and summarised in Eq. (4.52). More concretely, we project the entire Hilbert space $\mathcal{H} \times \bar{\mathcal{H}}$ onto those states which are invariant under Ω , i.e. we introduce the projection operator $\frac{1}{2}(1 + \Omega)$ into the partition function (6.39). In analogy to Eq. (4.52), we therefore obtain

$$\begin{aligned} \mathcal{Z}^\Omega(\tau, \bar{\tau}) &= \text{Tr}_{\mathcal{H} \times \bar{\mathcal{H}}} \left(\frac{1 + \Omega}{2} q^{L_0 - \frac{c}{24}} \bar{q}^{\bar{L}_0 - \frac{c}{24}} \right) \\ &= \frac{1}{2} \mathcal{Z}(\tau, \bar{\tau}) + \frac{1}{2} \text{Tr}_{\mathcal{H} \times \bar{\mathcal{H}}} \left(\Omega q^{L_0 - \frac{c}{24}} \bar{q}^{\bar{L}_0 - \frac{c}{24}} \right). \end{aligned}$$

The first term is just one-half of the torus partition function which we already studied. Let us therefore turn to the second term

$$\mathcal{Z}^\mathcal{K}(\tau, \bar{\tau}) = \text{Tr}_{\mathcal{H} \times \bar{\mathcal{H}}} \left(\Omega q^{L_0 - \frac{c}{24}} \bar{q}^{\bar{L}_0 - \frac{c}{24}} \right). \quad (6.41)$$

The insertion of Ω into the trace has the effect that by looping once around the direction τ of a torus, the closed string comes back to itself up to the action of Ω , that is, up to a change of orientation. Geometrically, such a diagram is not a torus but a Klein bottle illustrated in Fig. 6.5. This is also the reason for the superscript \mathcal{K} of the partition function and for its name: the Klein bottle partition function.

We will now specify the action of Ω as $\Omega(i) = i$ and $\Omega|0\rangle = +|0\rangle$ in order to make Eq. (6.41) more explicit. For this choice, we obtain

$$\langle i, \bar{j} | \Omega | i, \bar{j} \rangle = \langle i, \bar{j} | j, \bar{i} \rangle = \delta_{ij}, \tag{6.42}$$

where we used Eq. (6.40). Therefore, only left–right symmetric states $|i, \bar{i}\rangle$ contribute to the trace in Eq. (6.41) and we can simplify the partition function as follows:

$$\begin{aligned} \mathcal{Z}^{\mathcal{K}}(\tau, \bar{\tau}) &= \text{Tr}_{\mathcal{H} \times \bar{\mathcal{H}}} \left(\Omega q^{L_0 - \frac{c}{24}} \bar{q}^{\bar{L}_0 - \frac{\bar{c}}{24}} \right) \\ &= \sum_{i, \bar{j}} \langle i, \bar{j} | \Omega q^{L_0 - \frac{c}{24}} \Omega^{-1} \Omega \bar{q}^{\bar{L}_0 - \frac{\bar{c}}{24}} \Omega^{-1} \Omega | i, \bar{j} \rangle \\ &= \sum_i \langle i, \bar{i} | \bar{q}^{\bar{L}_0 - \frac{\bar{c}}{24}} q^{L_0 - \frac{c}{24}} | i, \bar{i} \rangle, \end{aligned}$$

where we employed Eq. (6.42). Since only the diagonal subset will contribute to the trace, we see from this expression that effectively L_0 and \bar{L}_0 as well as c and \bar{c} can be identified. Observing finally that $q\bar{q} = e^{-4\pi\tau_2}$, we arrive at

$$\mathcal{Z}^{\mathcal{K}}(\tau, \bar{\tau}) = \sum_i \langle i, \bar{i} | (q\bar{q})^{L_0 - \frac{c}{24}} | i, \bar{i} \rangle = \text{Tr}_{\mathcal{H}_{\text{sym}}} \left(e^{-4\pi t(L_0 - \frac{c}{24})} \right), \tag{6.43}$$

with $t = \tau_2$ and \mathcal{H}_{sym} denoting the states $|i, \bar{i}\rangle$ in the Hilbert space which are combined in a left–right symmetric way.

Free Boson III: Klein Bottle Partition Function (Loop-Channel)

Let us now determine the Klein bottle partition function for the example of the free boson. As it is evident from Eq. (6.43), this partition function is the character of the free boson theory with modular parameter $\tau = 2it$. However, for the momentum contribution, we need to perform a calculation similar to the one in the open sector shown on p. 213. In particular, from Eq. (6.43) we extract the j_0 part, replace the sum by an integral and compute

$$\text{Tr}_{\mathcal{H}_{\text{sym}}} \left(e^{-4\pi t \frac{1}{2} j_0^2} \right) \longrightarrow \int_{-\infty}^{+\infty} d\pi_0 e^{-4\pi t \frac{1}{2} \pi_0^2} = \frac{1}{\sqrt{2t}},$$

where we observed that in the closed sector $j_0 = \pi_0$. Combining this result with the character of the free boson theory, we obtain the following expression for the full Klein bottle partition function:

$$\mathcal{Z}_{\text{bos.}}^{\mathcal{K}}(\tau, \bar{\tau}) = \frac{1}{\sqrt{2t}} \frac{1}{\eta(2it)} . \tag{6.44}$$

Partition Function: Möbius Strip

After having studied CFTs on non-orientable surfaces in the closed sector, let us now turn to the open sector. Again, the partition function has to be projected onto states invariant under the orientifold action Ω . Following the same steps as for the closed sector, we find

$$\mathcal{Z}^{\Omega}(t) = \text{Tr}_{\mathcal{H}_B} \left(\frac{1 + \Omega}{2} e^{-2\pi t(L_0 - \frac{c}{24})} \right) = \frac{1}{2} \mathcal{Z}^{\mathcal{C}}(t) + \frac{1}{2} \text{Tr}_{\mathcal{H}_B} \left(\Omega e^{-2\pi t(L_0 - \frac{c}{24})} \right) .$$

The first term contains the cylinder amplitude, but the second term

$$\mathcal{Z}^{\mathcal{M}}(t) = \text{Tr}_{\mathcal{H}_B} \left(\Omega e^{-2\pi t(L_0 - \frac{c}{24})} \right) \tag{6.45}$$

describes an open string whose orientation changes when looping along the t direction. The geometry of such a surface is that of a Möbius strip also shown in Fig. 6.5. The corresponding partition function is called the Möbius strip partition function and hence the superscript \mathcal{M} .

Free Boson IV: Möbius Strip Partition Function (Loop-Channel)

We now calculate the Möbius strip partition function for the free boson. Recalling our notation (4.12) from the beginning of Sect. 4.2.1 and the mapping (6.37), we see that the action of Ω on a state is

$$\Omega |n_1, n_2, n_3, \dots\rangle = \prod_{k=1}^{\infty} (\pm 1)^{n_k} (-1)^{k n_k} |n_1, n_2, n_3, \dots\rangle .$$

Performing then the same steps as in the calculation on p. 121 with the action of Ω on the states taken into account, we arrive at

$$\begin{aligned} \text{Tr}_{\mathcal{H}_B} \left(\Omega q^{L_0 - \frac{c}{24}} \right) \Big|_{\text{without } j_0} &= q^{-\frac{1}{24}} \prod_{k=1}^{\infty} \sum_{n_k=0}^{\infty} (\pm 1)^{n_k} (-1)^{k n_k} q^{k n_k} \\ &= e^{\frac{\pi i}{24}} (-q)^{-\frac{1}{24}} \prod_{k=1}^{\infty} \frac{1}{1 \mp (-q)^k} . \end{aligned} \tag{6.46}$$

We also note that $-q$ with modular parameter τ can be expressed as $+q$ with modular parameter $\tau + \frac{1}{2}$.

For Neumann–Neumann boundary conditions, i.e. for the upper sign in the expression above, we employ the definition of the Dedekind η -function. However, since the momentum π_0 is unconstrained, we compute

$$\text{Tr}_{\mathcal{H}_B} \left(\Omega e^{-2\pi t \frac{1}{2} j_0^2} \right) \longrightarrow \int_{-\infty}^{+\infty} d\pi_0 e^{-2\pi t \frac{1}{2} (2\pi_0)^2} = \frac{1}{2\sqrt{t}},$$

where we used that j_0 is invariant under Ω as well as that in the open sector $j_0 = 2\pi_0$. The full Möbius strip partition function in the Neumann–Neumann sector then reads

$$\mathcal{Z}_{\text{bos.}}^{\mathcal{M}(\text{N},\text{N})}(t) = e^{\frac{\pi i}{24}} \frac{1}{2\sqrt{t}} \frac{1}{\eta(\frac{1}{2} + it)}. \tag{6.47}$$

For Dirichlet–Dirichlet conditions, that means the lower sign in Eq. (6.46), we find for instance from Eq. (6.37) that $j_0 = 0$ so that there is no additional factor from the momentum integration. Recalling the definition of the ϑ_2 -function summarised on p. 137, we obtain

$$\mathcal{Z}_{\text{bos.}}^{\mathcal{M}(\text{D},\text{D})}(t) = e^{\frac{\pi i}{24}} \sqrt{2} \frac{\eta(\frac{1}{2} + it)}{\vartheta_2(\frac{1}{2} + it)}. \tag{6.48}$$

For mixed boundary conditions, the Möbius strip partition function vanishes as Ω exchanges Neumann–Dirichlet with Dirichlet–Neumann conditions and so there is no contribution to the trace.

Loop-Channel – Tree-Channel Equivalence

For the cylinder partition function, we have seen that the result in the open and closed sectors are related via a modular S -transformation. One might therefore suspect that this equivalence between partition functions and overlaps of boundary states can also be found for non-orientable surfaces.

This is indeed the case which we illustrate in Fig. 6.6 for the Klein bottle partition function.

1. The fundamental domain of the Klein bottle shown in Fig. 6.6(a) is that of a torus up to a change of orientation. However, as opposed to the torus, the modular parameter of the Klein bottle is purely imaginary.
2. In Fig. 6.6(b), the fundamental domain is halved and the identification of segments and points is indicated explicitly by arrows and symbols.
3. Next, we shift one-half of the fundamental domain as shown in Fig. 6.6(c).

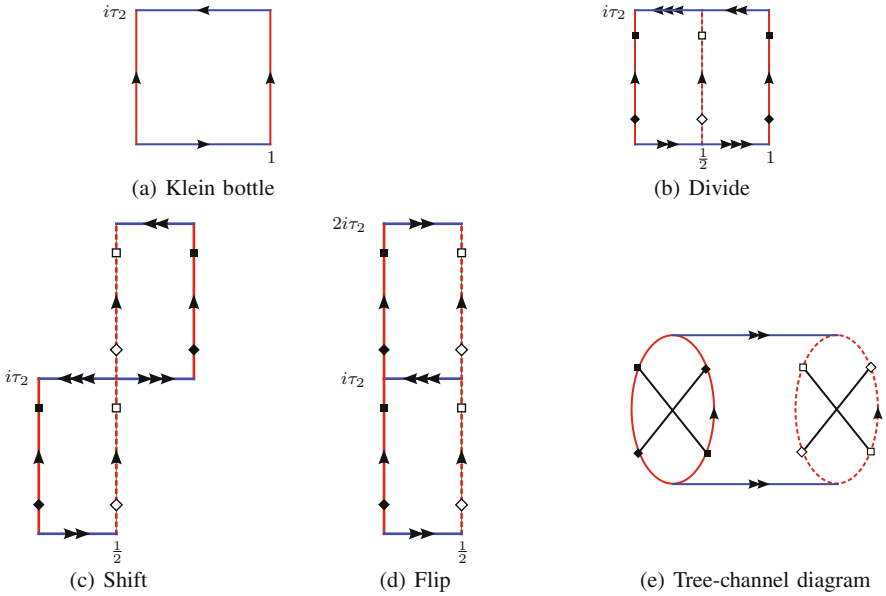

Fig. 6.6 Transformation of the fundamental domain of the Klein bottle to a tree-channel diagram between two crosscaps

4. In Fig. 6.6(d), the shifted part has been flipped and the appropriate edges have been identified.
5. A fundamental domain of this form can be interpreted as a cylinder between two crosscaps as illustrated in Fig. 6.6(e).

Analogous to the cylinder diagram (6.21), we expect now that the Klein bottle amplitude can be computed as the overlap of two so-called *crosscap* states $|C\rangle$ in the following way:

$$\tilde{\mathcal{Z}}^{\mathcal{K}}(l) = \langle \Theta C | e^{-2\pi l(L_0 + \bar{L}_0 - \frac{c+\bar{c}}{24})} | C \rangle . \tag{6.49}$$

Considering then again Fig. 6.6(d) and Eq. (4.6) from Chap. 4, we determine the modular parameter in the tree- and loop-channels as

$$\tau_{\text{open}} = \frac{\alpha_2}{\alpha_1} = \frac{2it}{\frac{1}{2}} = 4it , \quad \tau_{\text{closed}} = \frac{\alpha_2}{\alpha_1} = \frac{i}{l} ,$$

and because of the tree-channel–loop-channel equivalence, they have to be equal. This implies that the length of the cylinder in Fig. 6.6(e) and Eq. (6.49) can be expressed as $l = \frac{1}{4t}$. We will elaborate on these crosscap states in more detail in the next section.

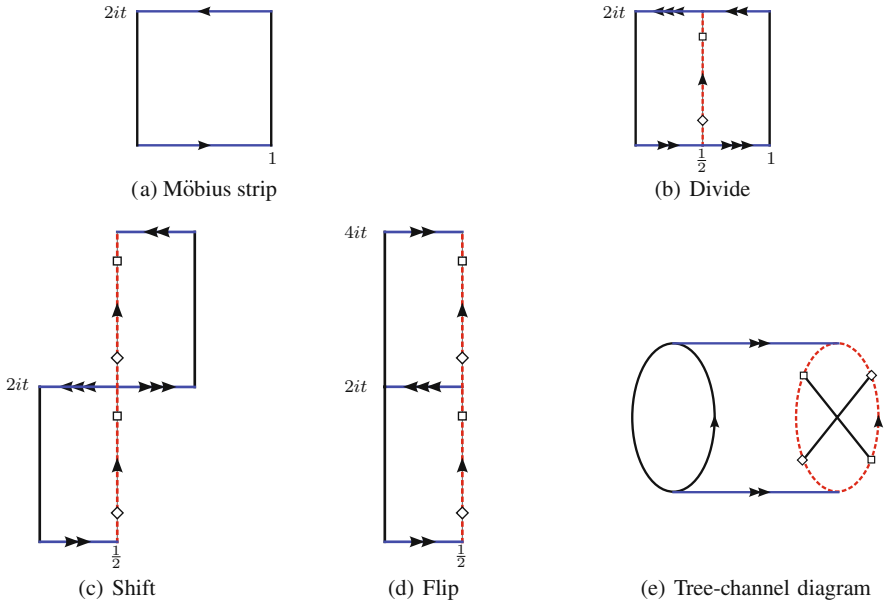

Fig. 6.7 Transformation of the fundamental domain of the Möbius strip to a tree-channel diagram between an ordinary boundary and a crosscap

For the Möbius strip amplitude, we can apply the same cuts and shifts as for the Klein bottle amplitude. As it is illustrated in Fig. 6.7, the resulting tree-channel diagram is a cylinder between an ordinary boundary and a crosscap. We thus expect that in the tree-channel, we can calculate the Möbius strip in the following way:

$$\tilde{\mathcal{Z}}^{\mathcal{M}}(l) = \langle \Theta C | e^{-2\pi l(L_0 + \bar{L}_0 - \frac{c+\bar{c}}{24})} | B \rangle . \tag{6.50}$$

Finally, for the modular parameters in the tree- and loop-channels, we obtain

$$\tau_{\text{open}} = \frac{\alpha_2}{\alpha_1} = \frac{4it}{\frac{1}{2}} = 8it , \quad \tau_{\text{closed}} = \frac{\alpha_2}{\alpha_1} = \frac{i}{l} ,$$

which leads us to $l = \frac{1}{8t}$.

Remarks

- A summary of the various loop-channel and tree-channel expressions together with their modular parameters can be found in Table 6.1.
- Almost all Ω projected CFTs in the closed sector are inconsistent and require the introduction of appropriate boundaries with corresponding boundary states. In

Table 6.1 Summary of loop-channel–tree-channel relations

	Loop-channel	$\tau = \dots$	Tree-channel	$l = \dots$
Torus	$\mathcal{Z}(\tau, \bar{\tau}) = \text{Tr}_{\mathcal{H} \times \bar{\mathcal{H}}} \left(q^{L_0 - \frac{c}{24}} \bar{q}^{\bar{L}_0 - \frac{c}{24}} \right)$	$\tau = \tau_1 + i\tau_2$		
Cylinder	$\mathcal{Z}^C(\tau) = \text{Tr}_{\mathcal{H}_S} \left(q^{L_0 - \frac{c}{24}} \right)$	$\tau = it$	$\tilde{\mathcal{Z}}^C(l) = (\Theta B e^{-2\pi l (L_0 + \bar{L}_0 - \frac{c, \bar{c}}{24})} B)$	$l = \frac{1}{2l}$
Klein bottle	$\mathcal{Z}^K(\tau, \bar{\tau}) = \text{Tr}_{\mathcal{H}_{S, \text{sym}}} \left(q^{L_0 - \frac{c}{24}} \right)$	$\tau = 2it$	$\tilde{\mathcal{Z}}^K(l) = (\Theta C e^{-2\pi l (L_0 + \bar{L}_0 - \frac{c, \bar{c}}{24})} C)$	$l = \frac{1}{4l}$
Möbius strip	$\mathcal{Z}^M(\tau) = \text{Tr}_{\mathcal{H}_S} \left(\Omega q^{L_0 - \frac{c}{24}} \right)$	$\tau = it$	$\tilde{\mathcal{Z}}^M(l) = (\Theta B e^{-2\pi l (L_0 + \bar{L}_0 - \frac{c, \bar{c}}{24})} C)$	$l = \frac{1}{8l}$

string theory, these conditions are known as the tadpole cancellation conditions which we will discuss in Sect. 6.7.

6.5 Crosscap States for the Free Boson

Similarly to boundary states which describe the coupling of the closed sector of a CFT to a boundary, for orientifold theories there should exist a coherent state describing the coupling of the closed sector to the crosscap. In particular, analogous to the observation that a world-sheet boundary defines (or is confined to) a space–time D-brane, we say that a world-sheet crosscap defines (or is confined to) a space–time orientifold plane.

In this section, we will discuss crosscap states for the example of the free boson, and in the next section, we are going to generalise the appearing structure to RCFTs.

Crosscap Conditions

We start our study of crosscap states by recalling the transformation of the Klein bottle, and Möbius strip amplitude respectively, from the open to the closed sector shown in Figs. 6.6 and 6.7. There, we encountered a new type of boundary, the so-called crosscap, where opposite points are identified. For the construction of the crosscap state, we will employ this geometric intuition, however, later we also compute the tree-channel Klein bottle and Möbius strip amplitudes to check that they are indeed related via a modular transformation to the result in the loop-channel.

As it is illustrated in Fig. 6.8, in an appropriate coordinate system on a crosscap, we observe that points x on a circle are identified with $-x$. Parametrising this circle by $\sigma \in [0, 2\pi)$, we see that the identification $x \sim -x$ corresponds to $\sigma \sim \sigma + \pi$.

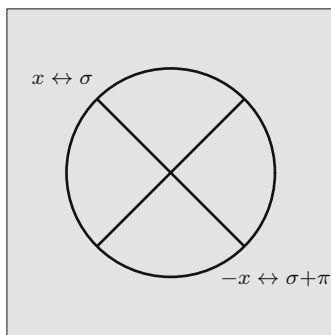

(a) Identification of points on a crosscap

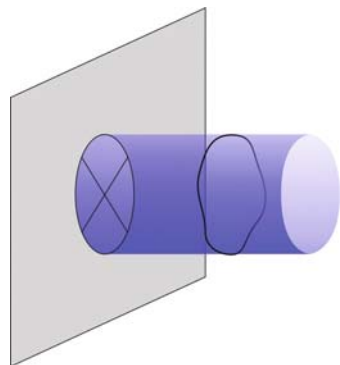

(b) Closed string at a crosscap

Fig. 6.8 Illustration of how points are identified on a crosscap, and how a closed string couples to a crosscap

For a closed string on a crosscap, we thus infer that the field X at (τ, σ) should be identified with the field X at $(\tau, \sigma + \pi)$. More concretely, this reads

$$X(\tau, \sigma) |C\rangle = X(\tau, \sigma + \pi) |C\rangle, \quad (6.51)$$

and for the derivatives with respect to τ and σ , we impose

$$\begin{aligned} (\partial_\sigma X)(\tau, \sigma) |C\rangle &= +(\partial_\sigma X)(\tau, \sigma + \pi) |C\rangle, \\ (\partial_\tau X)(\tau, \sigma) |C\rangle &= -(\partial_\tau X)(\tau, \sigma + \pi) |C\rangle. \end{aligned} \quad (6.52)$$

Let us now choose coordinates such that $\tau = 0$ describes the field $X(\tau, \sigma)$ at the crosscap $|C\rangle$. Using then the Laurent mode expansions (6.4) as well as Eq. (6.52) with $\tau = 0$, we obtain that

$$\begin{aligned} (j_n - \bar{j}_{-n}) |C\rangle &= +(-1)^n (j_n - \bar{j}_{-n}) |C\rangle, \\ (j_n + \bar{j}_{-n}) |C\rangle &= -(-1)^n (j_n + \bar{j}_{-n}) |C\rangle, \end{aligned}$$

where, similarly as in the computation for the boundary states, we performed a change in the summation index $n \rightarrow -n$. By adding or subtracting these two expressions, we arrive at the gluing conditions for crosscap states

$$\boxed{(j_n + (-1)^n \bar{j}_{-n}) |C_{O1}\rangle = 0}. \quad (6.53)$$

Note that we added the label O1 which stands for *orientifold one-plane*. The reason is that by inserting the expansion (6.7) of $X(\tau, \sigma)$ into Eq. (6.51), we see that the centre of mass coordinate x_0 of the closed string is unconstrained. In the target space, the location of the crosscap is called an orientifold plane which in the present case fills out one dimension because there is no constraint on x_0 . This explains the notation above.

Construction of Crosscap States

Apart from the factor $(-1)^n$, the gluing conditions (6.53) are very similar to those of a boundary state (6.15) with Neumann conditions. The solution to the gluing conditions is therefore also similar to the Neumann boundary state and reads

$$\boxed{|C_{O1}\rangle = \frac{\kappa}{\sqrt{2}} \exp\left(-\sum_{k=1}^{\infty} \frac{(-1)^k}{k} j_{-k} \bar{j}_{-k}\right) |0\rangle,} \quad (6.54)$$

where we employed Eq. (6.26) and allowed for a relative normalisation factor κ between the boundary state with Neumann conditions $|B_N\rangle$ and the crosscap state $|C_{01}\rangle$.

The proof that Eq. (6.54) is a solution to the gluing conditions (6.53) is analogous to the one shown on p. 218. Note in particular, the crosscap state can be written as

$$|C_{01}\rangle = \frac{\kappa}{\sqrt{2}} \sum_{\vec{m}} |\vec{m}\rangle \otimes |U\vec{m}\rangle, \quad (6.55)$$

with the anti-unitary operator U acting in the following way:

$$U \bar{j}_n U^{-1} = -(-1)^n (\bar{j}_{-n})^\dagger. \quad (6.56)$$

Remark

Let us make the following remark. In Eq. (6.33), we have chosen a specific orientifold action Ω for the fields $X(\tau, \sigma)$ which leaves the action (6.1) invariant. However, we can also accompany Ω by another operation, for instance $\mathcal{R} : X(\tau, \sigma) \mapsto -X(\tau, \sigma)$, which also leaves Eq. (6.1) invariant. The combined action then reads

$$\Omega \mathcal{R} : X(\tau, \sigma) \mapsto \tilde{X}(\tau, \sigma) = -X(\tau, -\sigma).$$

Note that this orientifold action describes a different theory and that there is no direct relation to the results obtained previously.

Performing the same steps as before, we arrive at the following expressions for the combined action $\Omega \mathcal{R}$ on the Laurent modes j_n and \bar{j}_n :

$$\begin{aligned} \text{closed sector} \quad \Omega \mathcal{R} j_n (\Omega \mathcal{R})^{-1} &= -\bar{j}_n, & \Omega \mathcal{R} \bar{j}_n (\Omega \mathcal{R})^{-1} &= -j_n, \\ \text{open sector} \quad \Omega \mathcal{R} j_n (\Omega \mathcal{R})^{-1} &= \mp (-1)^n j_n. \end{aligned}$$

For the action of \mathcal{R} on the states, we find

$$\mathcal{R} |\vec{m}\rangle = (-1)^{\sum_k m_k} |\vec{m}\rangle,$$

which results in additional factors of (-1) in various loop-channel amplitudes. Concerning the construction of crosscap states, also the identification (6.51) receives a factor of (-1) which results in gluing conditions of the form

$$(j_n - (-1)^n \bar{j}_{-n}) |C_{00}\rangle = 0,$$

which is similar to the Dirichlet conditions for boundary states. The notation O0 indicates that the orientifold plane does not extend in one dimension but is only a point. And indeed, using the expansion (6.7) of $X(\tau, \sigma)$ for $X(\tau, \sigma)|C\rangle =$

$-X(\tau, \sigma)|C\rangle$, we see that the centre of mass coordinate x_0 is constrained to $x_0 = 0$. Finally, we note that the solution to the gluing conditions in the present case reads

$$|C_{00}\rangle = \kappa \exp\left(+ \sum_{k=1}^{\infty} \frac{(-1)^k}{k} j_{-k} \bar{j}_{-k}\right) |0\rangle.$$

After this remark about a different possibility for an orientifold projection, let us continue our studies with our original choice (6.33) which leads to O1 crosscap states $|C_{01}\rangle$.

Free Boson V: Klein Bottle Amplitude (Tree-Channel)

As we have argued in the previous section, from the overlap of two crosscap states we can compute the Klein bottle amplitude (6.49) in the closed sector, that is, in the tree-channel. In order to do so, we recall the crosscap state (6.55) with the action of U given in Eq. (6.56). Noting for a basis state (6.18) that

$$U |\vec{m}\rangle = \prod_{k=1}^{\infty} (-1)^{m_k} (-1)^{m_k k} |\vec{m}\rangle, \tag{6.57}$$

and following the same calculation as in p. 221 for the overlap of two boundary states in the Neumann–Neumann sector, we obtain

$$\tilde{\mathcal{Z}}_{\text{bos.}}^{\mathcal{K}(O1,O1)}(l) = \langle \Theta C_{01} | e^{-2\pi l(L_0 + \bar{L}_0 - \frac{c+\bar{c}}{24})} |C_{01}\rangle = \frac{\kappa^2}{2\eta(2il)}. \tag{6.58}$$

Note that Θ is again the CPT operator introduced in Eq. (6.23) which, in particular, acts as complex conjugation on numbers. Finally, recalling from Table 6.1 the relation $l = \frac{1}{4t}$ between the tree-channel and loop-channel modular parameters, we find the loop-channel amplitude to be of the form

$$\tilde{\mathcal{Z}}_{\text{bos.}}^{\mathcal{K}(O1,O1)}(l) = \frac{\kappa^2}{2\eta(2il)} \xrightarrow{l=\frac{1}{4t}} \frac{\kappa^2}{2\eta\left(-\frac{1}{2it}\right)} = \frac{\kappa^2}{2\sqrt{2}t} \frac{1}{\eta(2it)},$$

where we employed the modular properties of the Dedekind η -function shown in Eq. (4.15). By comparing with the loop-channel result (6.44), we can now fix

$$\boxed{\kappa = \sqrt{2}}.$$

Free Boson VI: Möbius Strip Amplitude (Tree-Channel)

Eventually, we compute the overlap of a crosscap state and a boundary state giving the tree-level Möbius strip amplitude. Employing Eq. (6.57) and performing a

similar calculation as in p. 221, we find for the Möbius strip diagram in the Neumann sector that

$$\begin{aligned}
 \tilde{\mathcal{Z}}_{\text{bos.}}^{\mathcal{M}(O1,N)}(l) &= \langle \Theta C_{O1} | e^{-2\pi l(L_0 + \bar{L}_0 - \frac{c+\bar{c}}{24})} | B_N \rangle \\
 &= \frac{1}{\sqrt{2}} e^{\frac{\pi l}{6}} \prod_{k=1}^{\infty} \frac{1}{1 - (-e^{-4\pi l})^k} \\
 &= \frac{1}{\sqrt{2}} e^{\frac{\pi l}{24}} \frac{1}{\eta(\frac{1}{2} + 2il)},
 \end{aligned} \tag{6.59}$$

where we expressed (-1) as $e^{\pi i}$ and absorbed the additional factor into the definition of the modular parameter. The computation of the Möbius strip amplitude in the Dirichlet sector is very similar to the Neumann sector. We find

$$\begin{aligned}
 \tilde{\mathcal{Z}}_{\text{bos.}}^{\mathcal{M}(O1,D)}(l) &= \langle \Theta C_{O1} | e^{-2\pi l(L_0 + \bar{L}_0 - \frac{c+\bar{c}}{24})} | B_D \rangle \\
 &= e^{\frac{\pi l}{6}} \prod_{k=1}^{\infty} \frac{1}{1 + (-e^{-4\pi l})^k} \\
 &= \sqrt{2} e^{\frac{\pi l}{24}} \sqrt{\frac{\eta(\frac{1}{2} + 2il)}{\vartheta_2(\frac{1}{2} + 2il)}},
 \end{aligned}$$

where we used again the definition of the ϑ -functions. The momentum integration in this sector is trivial since j_0 acting on the crosscap state vanishes. This is again similar to the computation of the cylinder amplitude for mixed boundary conditions shown in p. 222.

Modular Transformations

After having computed the tree-channel Möbius strip amplitudes, we would like to transform these results to the loop-channel via the relation $l = \frac{1}{8r}$. However, by comparing with the loop-channel results Eqs. (6.47) and (6.48), we see that this cannot be achieved by a modular S -transformation. Instead, we have to perform the following combination of T - and S -transformations:

$$\mathcal{P} = T S T^2 S. \tag{6.60}$$

For the η -function with shifted argument, this transformation reads

$$\begin{aligned}
 \eta\left(\frac{1}{2} + 2il\right) &\xrightarrow{S} \eta\left(-\frac{1}{\frac{1}{2} + 2il}\right) \sqrt{\frac{i}{\frac{1}{2} + 2il}} \\
 &\xrightarrow{T^2} \eta\left(+\frac{4il}{\frac{1}{2} + 2il}\right) \sqrt{\frac{i}{\frac{1}{2} + 2il}} e^{-\frac{\pi i}{6}} \\
 &\xrightarrow{S} \eta\left(-\frac{\frac{1}{2} + 2il}{4il}\right) \sqrt{\frac{i}{\frac{1}{2} + 2il}} \sqrt{\frac{\frac{1}{2} + 2il}{4l}} e^{-\frac{\pi i}{6}} \\
 &\xrightarrow{T} \eta\left(\frac{1}{2} + \frac{i}{8l}\right) \frac{1}{\sqrt{4l}} \sqrt{i} e^{-\frac{\pi i}{6}} e^{-\frac{\pi i}{12}} \\
 &= \eta\left(\frac{1}{2} + \frac{i}{8l}\right) \frac{1}{\sqrt{4l}},
 \end{aligned}$$

where in the last step we employed that $\sqrt{i} = e^{\frac{\pi i}{4}}$. For the Möbius strip amplitude with Neumann boundary conditions, we then compute the transformation from the tree-channel to the loop-channel as follows:

$$\tilde{\mathcal{Z}}_{\text{bos.}}^{M(O1,N)}(l) = \frac{e^{\frac{\pi i}{24}}}{\sqrt{2}} \frac{1}{\eta\left(\frac{1}{2} + 2il\right)} \xrightarrow[l=\frac{1}{8l}]{\mathcal{P}} e^{\frac{\pi i}{24}} \frac{1}{2\sqrt{l}} \frac{1}{\eta\left(\frac{1}{2} + il\right)}.$$

By comparing with the loop-channel result (6.47), we have verified the loop-channel–tree-channel equivalence for the Möbius strip amplitude in the Neumann sector.

In passing, we note that the Möbius strip loop- and tree-channel amplitudes for the Dirichlet sector are also related via a modular \mathcal{P} -transformation. In the same manner as above, one can then establish the loop-channel–tree-channel equivalence.

New Characters

In the last paragraph of this section, let us introduce a more general notation for the Möbius strip characters. We define *hatted* characters $\widehat{\chi}(\tau)$ in terms of the usual characters $\chi(\tau)$ as follows:

$$\widehat{\chi}(\tau) = e^{-\pi i \left(h - \frac{c}{24}\right)} \chi\left(\tau + \frac{1}{2}\right). \tag{6.61}$$

The action of the \mathcal{P} -transformation (6.60) for the new characters $\widehat{\chi}(\tau)$ can be deduced as follows. From the mapping of the modular parameter $\tau = 2il$ under the combination of S - and T -transformations

$$2il \xrightarrow{T^{\frac{1}{2}}} 2il + \frac{1}{2} \xrightarrow{TST^2S} \frac{i}{8l} + \frac{1}{2} \xrightarrow{T^{-\frac{1}{2}}} \frac{i}{8l},$$

we can infer the transformation of the hatted characters $\widehat{\chi}(\tau)$ as

$$\widehat{\chi}_i\left(\frac{i}{8l}\right) = \sum_j P_{ij} \widehat{\chi}_j(2il) \quad \text{with} \quad P = T^{\frac{1}{2}} S T^2 S T^{\frac{1}{2}},$$

where $T^{\frac{1}{2}}$ is defined as the square root of the entries in the diagonal matrix T_{ij} shown in Eq. (4.56). Note that the P -transformation corresponds to the S -transformation of the usual characters, in particular, P realises the loop-channel–tree-channel equivalence.

Finally, using the properties of the S -matrix (4.54) as well as the relation $S^2 = (ST)^3 = C$ with C the charge conjugation matrix introduced in Eq. (4.31), we can show that

$$P^2 = C, \quad P^2 = C, \quad P P^\dagger = P^\dagger P = \mathbb{1}, \quad P^T = P. \tag{6.62}$$

6.6 Crosscap States for RCFTs

Let us now generalise the construction of crosscap states to conformal field theories without a Lagrangian description. In particular, we focus on RCFTs and we mainly state the general structure without explicit derivation.

Construction of Crosscap States

The crosscap gluing conditions for the generators of a symmetry algebra $\mathcal{A} \otimes \overline{\mathcal{A}}$ are in analogy to the conditions (6.53) for the example of the free boson and read

$$\begin{aligned} (L_n - (-1)^n \overline{L}_{-n}) |C\rangle &= 0 && \text{conformal symmetry,} \\ (W_n^i - (-1)^n (-1)^{h^i} \overline{W}_{-n}^i) |C\rangle &= 0 && \text{extended symmetries,} \end{aligned} \tag{6.63}$$

with again $h^i = h(W^i)$. For $\mathcal{A} = \overline{\mathcal{A}}$ and $\overline{\mathcal{H}}_i = \mathcal{H}_i^+$, we can define crosscap Ishibashi states $|C_i\rangle\rangle$ satisfying the crosscap gluing conditions. A crosscap state $|C\rangle$ can then be expressed as a linear combination of the crosscap Ishibashi states in the following way:

$$|C\rangle = \sum_i \Gamma^i |C_i\rangle\rangle. \tag{6.64}$$

In fact, the crosscap Ishibashi states and the boundary Ishibashi states are related via

$$|C_i\rangle\rangle = e^{\pi i(L_0 - h(\phi_i))} |\mathcal{B}_i\rangle\rangle. \tag{6.65}$$

Indeed, knowing that the boundary Ishibashi states $|\mathcal{B}_i\rangle\rangle$ satisfy the gluing conditions (6.27), we can show that Eq. (6.65) satisfies the crosscap gluing conditions. To do so, we compute

$$e^{-\pi i L_0} L_n e^{+\pi i L_0} = (-1)^n L_n, \quad e^{-\pi i L_0} W_n^i e^{+\pi i L_0} = (-1)^n W_n^i,$$

where we used that W^i is a primary field. For the generators of the conformal symmetry, we can then calculate

$$\begin{aligned} & e^{-\pi i(L_0-h(\phi_i))} (L_n - (-1)^n \bar{L}_{-n}) |C_i\rangle\rangle \\ &= e^{-\pi i(L_0-h(\phi_i))} (L_n - (-1)^n \bar{L}_{-n}) e^{\pi i(L_0-h(\phi_i))} |\mathcal{B}_i\rangle\rangle \\ &= (-1)^n (L_n - \bar{L}_{-n}) |\mathcal{B}_i\rangle\rangle \\ &= 0, \end{aligned}$$

and the condition for the extended symmetry generators is obtained along the same lines. Therefore, the crosscap Ishibashi states (6.65) satisfy the gluing conditions (6.63).

The Cardy Condition

Similarly to the boundary states, we expect generalisations of the Cardy condition arising from the loop-channel–tree-channel equivalences of the Klein bottle and Möbius strip amplitudes. In order to study this point, we compute the Klein bottle amplitude in the following way:

$$\begin{aligned} \tilde{\mathcal{Z}}^{\mathcal{K}}(l) &= \langle \Theta C | e^{-2\pi l(L_0 + \bar{L}_0 - \frac{c+\bar{c}}{24})} | C \rangle \\ &= \sum_{i,j} \Gamma^i \Gamma^j \langle \langle \mathcal{B}_{i+} | e^{\pi i(L_0-h(\phi_i))} e^{2\pi i(2il)(L_0-\frac{c}{24})} e^{\pi i(L_0-h(\phi_j))} | \mathcal{B}_j \rangle \rangle \\ &= \sum_{i,j} \Gamma^i \Gamma^j \delta_{ij} e^{-2\pi i(h(\phi_i)-\frac{c}{24})} \langle \langle \mathcal{B}_j | e^{2\pi i(2il+1)(L_0-\frac{c}{24})} | \mathcal{B}_j \rangle \rangle \\ &= \sum_i (\Gamma^i)^2 e^{-2\pi i(h(\phi_i)-\frac{c}{24})} \chi_i(2il+1) \\ &= \sum_i (\Gamma^i)^2 e^{-2\pi i(h(\phi_i)-\frac{c}{24})} \sum_j T_{ij} \chi_j(2il) = \sum_i (\Gamma^i)^2 \chi_i(2il), \end{aligned}$$

where Θ is again the CPT operator shown for instance in Eq. (6.32), and where we employed Eq. (6.30) as well as the modular T -matrix given in Eq. (4.56). In the next step, we perform a modular S -transformation to obtain the result in the loop-channel

$$\tilde{\mathcal{Z}}^{\mathcal{K}}(l) = \sum_i (\Gamma^i)^2 \chi_i(2il) = \sum_{i,j} (\Gamma^i)^2 S_{ij} \chi_j(2it).$$

Now, the Cardy condition is again the requirement that the expression above can be interpreted as a partition function. Since this partition function includes the action of the orientifold projection Ω , the coefficient in front of the character has to be integer but does not need to be non-negative

$$\sum_i (\Gamma^i)^2 S_{ij} = \kappa_j \in \mathbb{Z}.$$

For the Möbius strip amplitude, we compute along similar lines

$$\begin{aligned} \tilde{\mathcal{Z}}^{\mathcal{M}}(l) &= \langle \Theta C | e^{-2\pi l(L_0 + \bar{L}_0 - \frac{c+\bar{c}}{24})} | B_\alpha \rangle \\ &= \sum_{i,j} \Gamma^i B_\alpha^j \langle \langle \mathcal{B}_{i+} | e^{\pi i(L_0 - h(\phi_i))} e^{2\pi i(2il)(L_0 - \frac{c}{24})} | \mathcal{B}_j \rangle \rangle \\ &= \sum_{i,j} \Gamma^i B_\alpha^j \delta_{ij} e^{-\pi i(h(\phi_i) - \frac{c}{24})} \langle \langle \mathcal{B}_j | e^{2\pi i(2il + \frac{1}{2})(L_0 - \frac{c}{24})} | \mathcal{B}_j \rangle \rangle \\ &= \sum_i \Gamma^i B_\alpha^i e^{-\pi i(h(\phi_i) - \frac{c}{24})} \chi_i(2il + \frac{1}{2}) \\ &= \sum_i \Gamma^i B_\alpha^i \widehat{\chi}_i(2il) = \sum_{i,j} \Gamma^i B_\alpha^i P_{ij} \widehat{\chi}_j(it), \end{aligned}$$

where we employed the hatted characters (6.61) together with their modular transformation. Interpreting this expression as a loop-channel partition function, we see that the coefficients have to be integer:

$$\sum_i \Gamma^i B_\alpha^i P_{ij} = m_{\alpha j} \in \mathbb{Z}.$$

Similar to the Cardy boundary states, for the charge conjugate modular invariant partition function explained in p. 228, one can show that these integer conditions are satisfied for the reflection coefficients of the form

$$\Gamma^i = \frac{P_{0i}}{\sqrt{S_{0i}}}, \quad B_\alpha^i = \frac{S_{\alpha i}}{\sqrt{S_{0i}}}.$$

The Klein bottle and Möbius strip coefficients can then be written as two Verlinde type formulas

$$\kappa_j = \sum_i \frac{P_{0i} P_{0i} S_{ij}}{S_{0i}} = Y_{j0}^0, \quad m_{\alpha j} = \sum_i \frac{S_{\alpha i} P_{0i} P_{ij}}{S_{0i}} = Y_{\alpha j}^0.$$

From the relations (6.62), we can deduce $P_{ij}^* = P_{i+j}$ and in particular $P_{0i}^* = P_{0i}$, which allows us to establish the connection to the general coefficients

$$Y_{ij}^k = \sum_l \frac{S_{il} P_{jl} P_{kl}^*}{S_{0l}}.$$

As it turns out, the coefficients Y_{ij}^k are integer, guaranteeing that the loop-channel Klein bottle and Möbius strip amplitudes contain only integer coefficients.

Remark

With the techniques presented in this section, it is possible to construct many orientifolds of conformal field theories. However, one set of essential consistency conditions for the co-existence of crosscap and boundary states is still missing. These are the so-called tadpole cancellation conditions which we are going to discuss in a simple example in the final section of these lecture notes.

6.7 The Orientifold of the Bosonic String

We finally apply the techniques developed in this chapter to orientifold theories with boundaries and crosscaps. In particular, we are going to consider a string theory motivated but still sufficiently simple orientifold model which is the Ω projection of the bosonic string. More interestingly, this theory is actually analogous to the orientifold construction of the Type IIB superstring leading to the so-called Type I superstring. However, this needs a more detailed treatment of free fermions which we have not presented here and which is not necessary to understand the mathematical structure of such theories.

Details on the String Theory Construction

We have mentioned already on p. 70 that the bosonic string is only consistent in 26 flat space-time dimensions and is thus described by 26 free bosons $X^\mu(\sigma, \tau)$ with $\mu = 0, \dots, 25$. The quantisation of string theory in this description, the covariant quantisation, is slightly involved. However, by defining

$$X^+ = \frac{1}{\sqrt{2}}(X^0(\sigma, \tau) + X^1(\sigma, \tau)), \quad X^- = \frac{1}{\sqrt{2}}(X^0(\sigma, \tau) - X^1(\sigma, \tau)), \quad (6.66)$$

imposing the so-called light-cone gauge and using constraint equations, we are only left with the momentum p^+ as a degree of freedom. For the computation of the characters, we can therefore simply *ignore* the contribution from $X^0(\sigma, \tau)$ and $X^1(\sigma, \tau)$ so that we are left with the conformal field theory of 24 free bosons $X^I(\tau, \sigma)$ where $I = 2, \dots, 25$. Since the bosonic string is made out of 24 copies of the free boson CFT, for the computation of the partition functions we can use our previous results. These have been summarised in Table 6.2 for later reference.

In our previous definition of the open and closed sector partition functions, we employed the notion common to conformal field theory. However, for the relevant quantities in string theory, we have to integrate over the modular parameter of the torus, Klein bottle, cylinder and Möbius strip. After performing the integration over the light-cone momentum p^+ , the expressions relevant for the following are

Table 6.2 Summary of all loop- and tree-channel amplitudes for the example of the free boson with orientifold projection (6.33)

Loop-channel	Tree-channel
$\mathcal{Z}_{\text{bos.}}^T(\tau, \bar{\tau}) = \frac{1}{\sqrt{\tau_2}} \frac{1}{ \eta(\tau) ^2}$	
$\mathcal{Z}_{\text{bos.}}^{\mathcal{K}}(t) = \frac{1}{\sqrt{2t}} \frac{1}{\eta(2it)}$	$\tilde{\mathcal{Z}}_{\text{bos.}}^{\mathcal{K}(O1,O1)}(l) = \frac{1}{\eta(2il)}$
$\mathcal{Z}_{\text{bos.}}^{\mathcal{C}(N,N)}(t) = \frac{1}{2\sqrt{t}} \frac{1}{\eta(it)}$	$\tilde{\mathcal{Z}}_{\text{bos.}}^{\mathcal{C}(N,N)}(l) = \frac{1}{2\eta(2il)}$
$\mathcal{Z}_{\text{bos.}}^{\mathcal{C}(D,D)}(t) = \frac{1}{\eta(it)} e^{-\frac{1}{4\pi}(x_0^b - x_0^a)^2}$	$\tilde{\mathcal{Z}}_{\text{bos.}}^{\mathcal{C}(D,D)}(l) = \frac{1}{\sqrt{2l}} \frac{1}{\eta(2il)} e^{-\frac{1}{8\pi l}(x_0^b - x_0^a)^2}$
$\mathcal{Z}_{\text{bos.}}^{\mathcal{C}(\text{mixed})}(t) = \sqrt{\frac{\eta(it)}{\vartheta_4(it)}}$	$\tilde{\mathcal{Z}}_{\text{bos.}}^{\mathcal{C}(\text{mixed})}(l) = \sqrt{\frac{\eta(2il)}{\vartheta_2(2il)}}$
$\mathcal{Z}_{\text{bos.}}^{\mathcal{M}(N,N)}(t) = \frac{1}{2\sqrt{t}} \frac{1}{\eta(\frac{1}{2} + it)} e^{\frac{\pi i}{24}}$	$\tilde{\mathcal{Z}}_{\text{bos.}}^{\mathcal{M}(O1,N)}(l) = \frac{1}{\sqrt{2}} \frac{1}{\eta(\frac{1}{2} + 2il)} e^{\frac{\pi i}{24}}$
$\mathcal{Z}_{\text{bos.}}^{\mathcal{M}(D,D)}(t) = \sqrt{2} \sqrt{\frac{\eta(\frac{1}{2} + it)}{\vartheta_2(\frac{1}{2} + it)}} e^{\frac{\pi i}{24}}$	$\tilde{\mathcal{Z}}_{\text{bos.}}^{\mathcal{M}(O1,D)}(l) = \sqrt{2} \sqrt{\frac{\eta(\frac{1}{2} + 2il)}{\vartheta_2(\frac{1}{2} + 2il)}} e^{\frac{\pi i}{24}}$

$$\begin{aligned}
 Z^T &= \int_{\text{Teich}} \frac{d^2\tau}{\tau_2^2} \mathcal{Z}^T(\tau, \bar{\tau}), & Z^{\mathcal{C}} &= \int_0^\infty \frac{dt}{4t^2} \mathcal{Z}^{\mathcal{C}}(t), \\
 Z^{\mathcal{K}} &= \int_0^\infty \frac{dt}{2t^2} \mathcal{Z}^{\mathcal{K}}(t), & Z^{\mathcal{M}} &= \int_0^\infty \frac{dt}{4t^2} \mathcal{Z}^{\mathcal{M}}(t).
 \end{aligned}
 \tag{6.67}$$

The domain of integration for the torus amplitude Z^T is the so-called Teichmüller space. It is the space of all complex structures τ of a torus \mathbb{T}^2 which are not related via the $SL(2, \mathbb{Z})/\mathbb{Z}_2$ symmetry. An illustration can be found in Fig. 6.9 and the precise definition reads

$$\text{Teich} = \left\{ \tau \in \mathbb{C} : -\frac{1}{2} < \tau_1 \leq +\frac{1}{2}, |\tau| \geq 1 \right\}.
 \tag{6.68}$$

Fig. 6.9 The shaded region in this figure corresponds to the Teichmüller space of the two-torus \mathbb{T}^2

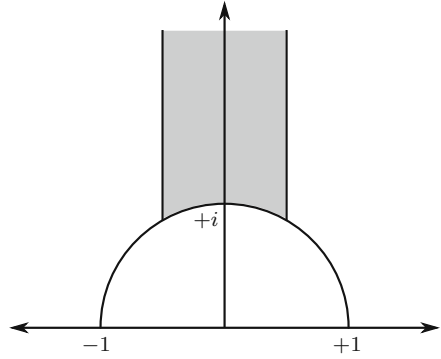

Torus Partition Function for the Bosonic String

Let us now become more concrete and determine the torus partition function for the bosonic string in light-cone gauge. Since this theory is a copy of 24 free bosons, we recall from Table 6.2 the form of $Z_{\text{bos.}}^T$, and combine it into

$$Z^T = \int_{\text{Teich}} \frac{d^2\tau}{\tau_2^2} \left(Z_{\text{bos.}}^T(\tau, \bar{\tau}) \right)^{24} = \int_{\text{Teich}} \frac{d^2\tau}{\tau_2^2} \frac{1}{\tau_2^{12}} \frac{1}{|\eta^{24}(\tau)|^2}. \tag{6.69}$$

In order to become more explicit, let us expand the Dedekind η -function in the following way:

$$\frac{1}{\eta^{24}(\tau)} = q^{-1} \left(1 + 24q + 324q^2 + \dots \right). \tag{6.70}$$

Using this expansion in Eq. (6.69) together with the string theoretical *level-matching condition* which leaves only equal powers of q and \bar{q} , we arrive at

$$\begin{aligned} Z^T &= \int_{\text{Teich}} \frac{d^2\tau}{\tau_2^{14}} e^{+4\pi\tau_2} \left| 1 + 24e^{2\pi i\tau} + \dots \right|^2 \\ &\longrightarrow \int_{\text{Teich}} \frac{d^2\tau}{\tau_2^{14}} e^{+4\pi\tau_2} \left(1 + (24)^2 e^{-4\pi\tau_2} + \dots \right). \end{aligned} \tag{6.71}$$

Let us now study the divergent behaviour of this integral.

- Although the integrand in Eq. (6.71) diverges for $\tau_2 \rightarrow 0$ due to the factor of τ_2^{-14} , the whole integral is finite because the domain of integration (6.68) does not include $\tau_2 = 0$. Therefore, this expression is not divergent in the *ultraviolet*, i.e. there is no singularity for small τ_2 . Let us emphasise that the finiteness in this parameter region is due to the modular invariance of the torus partition function which restricts the domain of integration to the Teichmüller space.

- Next, we turn to the behaviour of Eq. (6.71) for large τ_2 . We see that the first term gives rise to a divergence in the region $\tau_2 \rightarrow \infty$ which corresponds to a state with negative mass squared, i.e. a tachyon. Thus, the theory of the bosonic string is unstable. In more realistic theories, for instance the superstring, such a tachyon should be absent and we do not expect problems due to divergences in the *infrared*.
- In summary, the torus partition function of the bosonic string is finite in the ultraviolet due to modular invariance. In the infrared, the partition function is divergent due to a tachyon which renders the theory unstable.

Klein Bottle Partition Function for the Bosonic String

As the title of this section suggests, we want to study the orientifold of the bosonic string and so we have to determine the Klein bottle amplitude. Following the same steps as for the torus, we arrive at

$$Z^{\mathcal{K}}(t) = \frac{1}{2} \int_0^\infty \frac{dt}{t^2} \left(Z_{\text{bos.}}^{\mathcal{K}}(t) \right)^{24} = \frac{1}{2^{13}} \int_0^\infty \frac{dt}{t^{14}} \frac{1}{\eta^{24}(2it)}.$$

In order to simplify the integrand, we perform a transformation to the tree-channel with modular parameter $t = \frac{1}{4l}$ by employing the modular properties of the Dedekind η -function (4.15)

$$\begin{aligned} Z^{\mathcal{K}}(t) &\xrightarrow{t=\frac{1}{4l}} \tilde{Z}^{\mathcal{K}(\text{O25, O25})}(l) = \frac{1}{2^{13}} \int_0^\infty \frac{dl}{4l^2} (4l)^{14} \frac{1}{\eta^{24}\left(-\frac{1}{2il}\right)} \\ &= 2 \int_0^\infty dl \frac{1}{\eta^{24}(2il)}. \end{aligned}$$

The notation O25 deserves some explanation. Since we are studying the bosonic string in a 26-dimensional space–time, the orientifold projection naturally acts also on the light-cone coordinates (6.66). By choosing the orientifold projection (6.33), we have an orientifold plane extending over all 26 dimensions. However, the convention in string theory is such that only the space dimensions are counted which explains the term O25.

Similarly as for the torus partition function, let us now expand the tree-channel Klein bottle amplitude. Using Eq. (6.70), we obtain

$$\tilde{Z}^{\mathcal{K}(\text{O25, O25})}(l) = 2 \int_0^\infty dl \left(e^{4\pi l} + 24 + 324 e^{-4\pi l} + \dots \right). \quad (6.72)$$

The first term in Eq. (6.72) corresponds again to the tachyon and should be absent in more realistic theories. We therefore ignore this problematic behaviour. However, the second term corresponds to massless states and gives rise to a divergence since in the present case, the domain of integration includes $t = \frac{1}{4l} = 0$. This term will not

be absent in more refined theories and so at this point, the orientifold of the bosonic string is not consistent at a more severe level.

A Stack of D-Branes

As it turns out, the divergence of the Klein bottle diagram can be cancelled by introducing a to be determined number N of D25 branes. The notation D25 means that these D-branes fill out 25 spatial dimensions and it is understood that they always fill the time direction.

If we put a certain number of D-branes on top of each other, we call it a stack of D-branes. However, since there are now multiple branes, we can have new kinds of open strings. In particular, there are strings starting at D-brane i of our stack and ending on D-brane j . We thus include new labels, the so-called Chan–Paton labels, to our open string states

$$|\vec{m}, i, j\rangle = |\vec{m}\rangle \otimes |i, j\rangle,$$

where $|\vec{m}\rangle$ denotes the states for a single string and $i, j = 1, \dots, N$ label the starting, ending points, respectively. We furthermore construct the hermitian conjugate $\langle i, j|$ in the usual way such that

$$\langle i, j | i', j' \rangle = \delta_{ii'} \delta_{jj'}. \quad (6.73)$$

Next, we define the action of the orientifold projection acting on the Chan–Paton labels. Since Ω changes the orientation of the world-sheet, it clearly interchanges starting and ending points of open strings. But we can also allow for rotations among the D-branes and so a general orientifold action reads

$$\Omega |i, j\rangle = \sum_{i', j'=1}^N \gamma_{jj'} |j', i'\rangle (\gamma^{-1})_{ii'}, \quad (6.74)$$

where γ is a $N \times N$ matrix. Without presenting the detailed argument, we now require that the action of Ω on the Chan–Paton labels squares to the identity. For this we calculate

$$\begin{aligned} \Omega^2 |i, j\rangle &= \sum_{i'', j''=1}^N \gamma_{ii''} \left[\Omega |i, j\rangle^T \right]_{i'', j''} (\gamma^{-1})_{j'' j} \\ &= \sum_{i', j', i'', j''=1}^N \gamma_{ii''} (\gamma^{-1})_{i'' i'}^T |i', j'\rangle \gamma_{j' j''}^T (\gamma^{-1})_{j'' j} \\ &= \sum_{i', j'=1}^N \left[\gamma (\gamma^{-1})^T \right]_{ii'} |i', j'\rangle \left[\gamma^T \gamma^{-1} \right]_{j' j}, \end{aligned}$$

from which we infer the constraint on the matrices γ to be symmetric or anti-symmetric

$$\gamma^T = \pm \gamma . \tag{6.75}$$

In string theory, the two different signs correspond to gauge groups $SO(N)$ and $SP(N)$ living on the stack of D-branes.

Let us now come to the final part of this paragraph which is to determine the contribution of the Chan–Paton labels to the partition function. For the cylinder partition function, we calculate with the help of Eq. (6.73)

$$\begin{aligned} \mathcal{Z}^C(t) &= \text{Tr}_{\mathcal{H}_B} \left(q^{L_0 - \frac{c}{24}} \right) = \sum_n \langle n | q^{L_0 - \frac{c}{24}} | n \rangle \times \sum_{i,j=1}^N \langle i, j | i, j \rangle \\ &= \sum_n \langle n | q^{L_0 - \frac{c}{24}} | n \rangle \times N^2 . \end{aligned}$$

Therefore, the effect of N D-branes is taken care of by including the factor N^2 for the cylinder partition function. Let us next turn to the Möbius strip partition function. Concentrating only on the Chan–Paton part, we find using Eqs. (6.73) and (6.74) that

$$\begin{aligned} \sum_{i,j=1}^N \langle i, j | \Omega | i, j \rangle &= \sum_{i,j,i',j'=1}^N \langle i, j | \gamma_{jj'} | j', i' \rangle (\gamma^{-1})_{i'i} \\ &= \sum_{i,j,i',j'=1}^N \delta_{ij'} \delta_{j'i'} \gamma_{jj'} (\gamma^{-1})_{i'i} \\ &= \text{Tr} \left(\gamma^T \gamma^{-1} \right) = \pm N , \end{aligned}$$

where in the final step we also employed Eq. (6.75). In summary, by including a factor of $\pm N$ in the Möbius strip partition function, we can account for a stack of N D-branes.

Cylinder and Möbius Strip Partition Function for the Bosonic String

After this discussion about stacks of D-branes, let us now compute the cylinder and Möbius strip partition functions for a stack of N D25-branes. Since the D-branes fill out the 26-dimensional space–time, the open strings always have Neumann–Neumann boundary conditions.

For the cylinder, we recall from Table 6.2 the form of a single cylinder partition function and combine it with the relevant expression from Eq. (6.67) to obtain

$$Z^{C(N,N)}(t) = \frac{N^2}{4} \int_0^\infty \frac{dt}{t^2} \left(Z_{\text{bos.}}^{C(N,N)}(t) \right)^{24} = \frac{N^2}{2^{26}} \int_0^\infty \frac{dt}{t^{14}} \frac{1}{\eta^{24}(it)},$$

where we included the factor N^2 as explained above. In order to extract the divergences, we perform a transformation from the loop- to the tree-channel via $t = \frac{1}{2l}$ to find

$$\begin{aligned} Z^{C(N,N)}(t) \xrightarrow{t=\frac{1}{2l}} \tilde{Z}^{C(N,N)}(l) &= \frac{N^2}{2^{26}} \int_0^\infty \frac{dl}{2l^2} (2l)^{14} \frac{1}{\eta^{24}\left(-\frac{1}{2il}\right)} \\ &= \frac{N^2}{2^{25}} \int_0^\infty dl \frac{1}{\eta^{24}(2il)}. \end{aligned}$$

With the help of Eq. (6.70), we can again expand this expression. The first terms read as follows

$$\tilde{Z}^{C(N,N)}(l) = \frac{N^2}{2^{25}} \int_0^\infty dl \left(e^{4\pi l} + 24 + 324 e^{-4\pi l} + \dots \right).$$

Next, we turn to the Möbius strip contribution. Along similar lines as above, we recall from Table 6.2 the expression for the partition function of a single free boson and combine 24 copies of it into the Möbius partition function

$$Z^{\mathcal{M}(N,N)}(t) = \pm \frac{N}{4} \int_0^\infty \frac{dt}{t^2} \left(Z_{\text{bos.}}^{\mathcal{M}(N,N)}(t) \right)^{24} = \pm \frac{N}{2^{26}} \int_0^\infty \frac{dt}{t^{14}} \frac{e^{\pi i}}{\eta^{24}\left(\frac{1}{2} + it\right)}.$$

In order to extract the divergences more easily, we transform this expression into the tree-channel via the relation $t = \frac{1}{8l}$ and the modular \mathcal{P} transformation (6.60)

$$\begin{aligned} Z^{\mathcal{M}(N,N)}(t) \xrightarrow{t=\frac{1}{8l}} \tilde{Z}^{\mathcal{M}(N,N)}(l) &= \pm \frac{N}{2^{26}} \int_0^\infty \frac{dl}{8l^2} (8l)^{14} \frac{e^{\pi i}}{\eta^{24}\left(\frac{1}{2} + \frac{i}{8l}\right)} \\ &= \pm \frac{N}{2^{11}} \int_0^\infty dl \frac{e^{\pi i}}{\eta^{24}\left(\frac{1}{2} + 2il\right)}. \end{aligned}$$

Expanding this expression with the help of Eq. (6.70), we find

$$\tilde{Z}^{\mathcal{M}(N,N)}(l) = \pm \frac{N}{2^{11}} \int_0^\infty dl \left(e^{4\pi l} - 24 + 324 e^{-4\pi l} - \dots \right).$$

Tadpole Cancellation Condition

After having determined the divergent contributions of the one-loop amplitudes, we can now combine them into the full expression. Leaving out the torus amplitude, we find

$$\begin{aligned}
& \frac{1}{2} \left(\tilde{Z}^{\mathcal{K}(0,25,0,25)}(l) + \tilde{Z}^{\mathcal{C}(N,N)}(l) + \tilde{Z}^{\mathcal{M}(N,N)}(l) \right) \\
&= 2^{-26} \int_0^\infty dl \left(\begin{aligned} & e^{4\pi l} \left(2^{26} \pm 2 \cdot 2^{13} N + N^2 \right) \\ & + 24 \left(2^{26} \mp 2 \cdot 2^{13} N + N^2 \right) \\ & + 324 e^{-4\pi l} \left(2^{26} \pm 2 \cdot 2^{13} N + N^2 \right) + \dots \end{aligned} \right). \tag{6.76}
\end{aligned}$$

The first terms with prefactor $e^{4\pi l}$ stem again from the tachyon which in a more realistic theory, e.g. Superstring Theory, should be absent. We will therefore ignore this divergence. The next line with prefactor 24 corresponds to massless states which will not be absent in more refined theories. However, we can simplify this expression by noting that

$$\left(2^{26} \mp 2 \cdot 2^{13} N + N^2 \right) = \left(2^{13} \mp N \right)^2.$$

We thus see that by taking $N = 2^{13} = 8192$ D25-branes and choosing the minus sign corresponding to $SO(N)$ gauge groups, the divergence is cancelled. In summary, we have found that

For the orientifold of the bosonic string with $N = 8192$ D25-branes and gauge group $SO(8192)$, the divergence due to massless states is cancelled. This is the famous tadpole cancellation condition for the bosonic string.

Finally, it is easy to see that the proceeding terms in Eq. (6.76) with prefactors $e^{-4\pi l}$ and powers thereof do not give rise to divergences in the integral.

Remarks

- Here we have discussed a very simple example for a CFT with boundaries. The next step is to generalise these methods for the superstring, in which case we have to define boundary and crosscap states for the CFT of the free fermion. The orientifold of the Type IIB superstring defines the so-called Type I string living in ten dimensions and carrying gauge group $SO(32)$ instead of $SO(8192)$.
- Many examples of such orientifold models have been discussed for compactified dimensions. These include orientifolds on toroidal orbifolds and also orientifolds of Gepner models. For this purpose, one first has to find classes of boundary and crosscap states for the $\mathcal{N} = 2$ unitary models and then for Gepner models, in which the simple current construction is utilised in an essential way. Finally, one has to derive and solve the tadpole cancellation conditions. All this is a feasible exercise but beyond the scope of these lecture notes.

Further Reading

1. J. L. Cardy, “Boundary conditions, fusion rules and the Verlinde formula,” *Nucl. Phys.* **B324** (1989) 581.
2. J. Polchinski and Y. Cai, “Consistency of open superstring theories,” *Nucl. Phys.* **B296** (1988) 91.
3. G. Pradisi and A. Sagnotti, “Open string orbifolds,” *Phys. Lett.* **B216** (1989) 59.
4. N. Ishibashi, “The boundary and crosscap states in conformal field theories,” *Mod. Phys. Lett.* **A4** (1989) 251.
5. M. Bianchi and A. Sagnotti, “On the systematics of open string theories,” *Phys. Lett.* **B247** (1990) 517–524.
6. G. Pradisi, A. Sagnotti, and Y. S. Stanev, “Planar duality in $SU(2)$ WZW models,” *Phys. Lett.* **B354** (1995) 279–286, [hep-th/9503207](#).
7. E. G. Gimon and J. Polchinski, “Consistency conditions for orientifolds and D-manifolds,” *Phys. Rev.* **D54** (1996) 1667–1676, [hep-th/9601038](#).
8. A. Recknagel and V. Schomerus, “D-branes in Gepner models,” *Nucl. Phys.* **B531** (1998) 185–225, [hep-th/9712186](#).
9. C. Angelantonj and A. Sagnotti, “Open strings,” *Phys. Rept.* **371** (2002) 1–150, [hep-th/0204089](#).
10. M. Bianchi and A. Sagnotti, “The partition function of the $SO(8192)$ bosonic string,” *Phys. Lett.* **B211** (1988) 407.

Concluding Remarks

Let us conclude these lecture notes with some remarks. Although we have covered many aspects of conformal field theory, we could only scratch the surface and provide an introduction to a collection of CFT issues. For further reading and study, we have provided a list of essential references at the end of these notes.

However, coming back to our introduction, this course was meant to accompany a string theory lecture as part of the 2007 newly established “Theoretical and Mathematical Physics” master programme at the LMU Munich. As a consequence, we put special emphasis on computational techniques in CFT which are important for string theory and had to neglect directions in CFT which are also important but have their roots in Statistical Physics or pure Mathematical Physics. For the interested reader, let us give a (incomplete) list of developments not covered in these notes:

- We have focused on unitary CFTs, as they are important for string theory, though, it is well known that non-unitary CFTs with negative central charge play a very important role for statistical integrable models in two dimensions. These issues are discussed for instance in the book by di Francesco, Mathieu, Sénéchal.
- We have only mentioned the basics about symmetry algebras in CFT. In particular, the field of Kač–Moody algebras would have deserved a much more detailed discussion, as they also play a very important role in mathematics. Their generalisation to \hat{e}_{10} and \hat{e}_{11} might turn out to be essential for a non-perturbative formulation of String and M-Theory, respectively. Similarly, the vast field of \mathcal{W} algebras could only be touched.
- We have discussed some aspects of free field CFT, however, interacting CFTs can be constructed from free fields by allowing for a non-vanishing background charge. This is the celebrated Feigin–Fuks construction which we also did not cover.
- Again related to non-unitary CFTs, we did not touch the very much discussed Logarithmic conformal field theories.
- There exist a number of interesting attempts to develop an axiomatic approach to CFT which we did not mention, since our emphasis was on applications of CFT techniques to string theory.

General Books on CFT and String Theory

1. P. H. Ginsparg, "Applied Conformal Field Theory: Lectures given at Les Houches Summer School in Theoretical Physics." Les Houches, France: Published in Les Houches Summer School (Jun 28 – Aug 5, 1988) pp. 1–168, arXiv:hep-th/9108028.
2. C. Itzykson, H. Saleur, and J. B. Zuber, "Conformal invariance and application to statistical mechanics,". Singapore, Singapore: World Scientific (1988) 979p.
3. S. V. Ketov, "Conformal field theory,". Singapore, Singapore: World Scientific (1995) 486p.
4. P. Di Francesco, P. Mathieu, and D. Sénéchal, "Conformal field theory,". New York, USA: Springer (1997) 890p.
5. M. Schottenloher, "A Mathematical Introduction to Conformal Field Theory," *Lect. Notes Phys.* **759** (2008).
6. J. Fuchs, "Lectures on conformal field theory and Kac-Moody algebras," hep-th/9702194.
7. J. Fuchs and C. Schweigert, "Symmetries, Lie algebras and representations: A graduate course for physicists,". Cambridge, UK: University Press (1997) 438p.
8. M. R. Gaberdiel and P. Goddard, "Axiomatic conformal field theory," *Commun. Math. Phys.* **209** (2000) 549–594, hep-th/9810019.
9. M. R. Gaberdiel, "An introduction to conformal field theory," *Rept. Prog. Phys.* **63** (2000) 607–667, hep-th/9910156.
10. C. Schweigert, J. Fuchs, and J. Walcher, "Conformal field theory, boundary conditions and applications to string theory," hep-th/0011109.
11. M. Flohr, "Bits and pieces in logarithmic conformal field theory," *Int. J. Mod. Phys. A* **18** (2003) 4497–4592, hep-th/0111228.
12. M. B. Green, J. H. Schwarz, and E. Witten, "Superstring theory. vol. 1: Introduction,". Cambridge, UK: University Press (1987) 469p. (Cambridge Monographs on Mathematical Physics).
13. M. B. Green, J. H. Schwarz, and E. Witten, "Superstring theory. vol. 2: Loop amplitudes, anomalies and phenomenology,". Cambridge, UK: University Press (1987) 596p. (Cambridge Monographs on Mathematical Physics).
14. D. Lüst and S. Theisen, "Lectures on string theory," *Lect. Notes Phys.* **346** (1989) 1–346.
15. J. Polchinski, "String theory. vol. 1: An introduction to the bosonic string,". Cambridge, UK: University Press (1998) 402p.
16. J. Polchinski, "String theory. vol. 2: Superstring theory and beyond,". Cambridge, UK: University Press (1998) 531p.
17. B. Zwiebach, "A first course in string theory,". Cambridge, UK: University Press (2004) 558p.
18. K. Becker, M. Becker, and J. H. Schwarz, "String theory and M-theory: A modern introduction,". Cambridge, UK: Cambridge University Press (2007) 739p.
19. E. Kiritsis, "String theory in a nutshell,". Princeton, USA: University Press (2007) 588p.
20. B. R. Greene, "String theory on Calabi-Yau manifolds," hep-th/9702155.

Index

A

- A-D-E classification, 148
- action
 - free boson, 45
 - free fermion, 57
 - ghost system (b, c) , 67
- algebra
 - complex fermion, 65
 - current, 37, 47, 54, 55, 87
 - fusion, 80, 143
 - Kač-Moody, 37, 55, 87
 - $\mathcal{N} = 1$ super Virasoro, 172
 - $\mathcal{N} = 2$ super Virasoro, 177
 - $\widehat{\mathfrak{so}}(N)_1$, 97
 - $\widehat{\mathfrak{su}}(2)_k$, 92
 - super Lie, 173
 - Virasoro, 16, 26, 36, 49
 - \mathcal{W} , 106, 109, 154
 - $\mathcal{W}(2, 3)$, 108, 151
 - $\mathcal{W}(2, 4)$, 110
 - Witt, 13
- asymptotic growth of states, 164

B

- boot-strap approach, 76, 84
- bosonic string
 - cylinder partition function, 253
 - gauge group, 255
 - Klein bottle partition function, 251
 - Möbius strip partition function, 253
 - tadpole cancellation, 254
 - torus partition function, 250
- bosonic string map, 193, 194, 199
- bosonisation, 66, 133
- boundary condition
 - conformal symmetry, 219
 - crosscap, 239
 - Dirichlet, 207, 209, 215
 - free boson, 207, 215

- Laurent modes, 209
- Neumann, 207, 209, 215
 - solution for free boson, 209
- boundary state, 214, 215
 - free boson, 216
 - momentum dependence, 218
 - RCFT, 227
 - simple current, 229
- braiding matrix, 84
- branching function, 150, 152, 188
- branching rule, 105, 152, 188

C

- Cardy condition, 228, 246
- Casimir operator, 94
- Cauchy-Riemann equations, 12
- central charge, 16
 - free boson, 49
 - free fermion, 62
 - ghost system (b, c) , 69
 - Kač-Moody algebra, 91
 - quotient theory, 103
 - string theory, 191, 248
- central extension, 15, 87
- Chan-Paton label, 252
- character, 127
 - charged, 132, 146
 - free fermion, 136
 - hatted, 244
 - $\mathcal{N} = 2$ unitary series, 189
 - $\widehat{\mathfrak{so}}(10)_1$, 192
 - $\widehat{\mathfrak{so}}(2)_1$, 180
 - $\widehat{\mathfrak{su}}(2)_k$, 146
 - summary, 155
 - $\widehat{\mathfrak{u}}(1)_k$, 129
- charge conjugation, 128, 142
- charged character, 146
- chiral ring, 183
- complex structure, 116

- conformal algebra
 - definition, 11
 - infinitesimal transformation, 11, 17
- conformal block, 83, 84
- conformal dimension, 18, 32, 44
 - free fermion, 58
 - parafermion, 153
 - spectral flow, 186
 - $\widehat{\mathfrak{su}}(2)_1$ highest weight state, 94
 - $\widehat{\mathfrak{u}}(1)_k$ highest weight state, 130
 - vertex operator, 53
- conformal family, 43, 30
- conformal field theory
 - Boundary, 205
 - $\mathcal{N} = 1$ Superconformal, 169
 - $\mathcal{N} = 2$ Superconformal, 175
 - Rational, 74, 127, 142, 167, 225
- conformal group
 - definition, 11
 - in dimension $d = 2$, 15
 - in dimensions $d \geq 3$, 11
- conformal transformation, 6, 13, 17
- conformal weight, *see* conformal dimension
- correlation function, 29
 - descendant field, 78
 - four-point function, 82
 - Kač-Moody primary fields, 99
 - non-chiral fields, 81
 - three-point function, 32
 - two-point function, 31, 46, 53
- coset construction, 102
 - $\mathcal{N} = 1$ unitary series, 106, 175
 - $\mathcal{N} = 2$ unitary series, 187
- CPT operator, 220
- crosscap, 230
- crosscap state, 236
 - boundary condition, 239
 - free boson, 240
- crossing ratio, 82
- crossing symmetry, 82, 83
- current
 - algebra, 37
 - definition, 37
- cylinder, 230
 - diagram, 220, 238
 - diagram RCFT, 228
 - diagram free boson, 221
 - modular parameter, 211
 - partition function, 211–213, 238
 - partition function bosonic string, 253
- D**
- D-brane, 205, 207, 211, 215, 225
- Chan-Paton label, 252
- stack, 252
- Dedekind η -function, 121, 221
 - modular transformation, 122, 138
- descendant field, 77
- di-logarithm identity, 167
- dual Coxeter number, 90
- E**
- energy-momentum tensor, 19, 26
 - free boson, 47
 - free fermion, 60
 - ghost system (b, c) , 68
 - $\mathcal{N} = 1$ super OPE, 174
 - $\mathcal{N} = 1$ superfield, 173
 - on the cylinder, 115
 - quotient theory, 103
 - Sugawara, 90
 - two-point function, 31
- F**
- field
 - anti-chiral, 18
 - anti-holomorphic, 18
 - chiral, 18
 - descendant, 43, 77
 - hermitian conjugate, 23
 - holomorphic, 18
 - Kač-Moody descendant, 100
 - Kač-Moody primary, 99, 102
 - $\mathcal{N} = 1$ super, 173
 - $\mathcal{N} = 1$ super primary, 174
 - $\mathcal{N} = 1$ super quasi-primary, 174
 - $\mathcal{N} = 2$ super chiral, 181
 - $\mathcal{N} = 2$ super primary, 181, 182
 - non-chiral, 81
 - primary, 18, 26, 28
 - quasi-primary, 18
 - secondary, 18
- fixed point of simple current, 157
- free boson, 44
 - action, 45
 - boundary condition, 207, 209, 215
 - boundary condition crosscap, 240
 - boundary state, 216
 - center of mass momentum, 49
 - center of mass position, 49
 - central charge, 49
 - crosscap state, 240
 - cylinder diagram, 221
 - cylinder partition function, 213
 - energy momentum tensor, 47
 - Hilbert space, 55
 - Klein bottle diagram, 242

- Klein bottle partition function, 234
- Möbius strip diagram, 242
- Möbius strip partition function, 234
- $\mathcal{N} = 1$ extension, 170
- $\mathcal{N} = 2$ extension, 175
- on circle, 122
- on circle of radius $R = \sqrt{2k}$, 126
- orientifold action, 229, 231
- realisation of $\widehat{\mathfrak{su}}(2)_1$, 96
- solution to boundary conditions, 209
- summary of amplitudes, 249
- two-point function, 46
- \mathbb{Z}_2 -orbifold, 138
- free fermion, 56
 - action, 57
 - central charge, 62
 - character, 136
 - complex, 63
 - conformal dimension, 58
 - energy-momentum tensor, 60
 - Hilbert space, 66
 - Laurent modes, 59
 - OPE, 59
 - partition function, 136
 - realisation of $\widehat{\mathfrak{so}}(N)_1$, 97
- fusion algebra, 80, 143
- fusion matrix, 84, 143
- fusion rules, 80
 - for $\widehat{\mathfrak{so}}(10)_1$, 193
 - for $\widehat{\mathfrak{so}}(2)_1$, 180
 - for $\widehat{\mathfrak{su}}(2)_1$, 144
 - for $\widehat{\mathfrak{su}}(2)_k$, 148
 - for $\widehat{\mathfrak{u}}(1)_k$, 144
- $\mathcal{N} = 2$ unitary series, 190
- G**
 - generator
 - modular group, 118
 - space translation, 22, 119
 - symmetry transformation, 24
 - time translation, 21, 118
 - Gepner model, 191, 194, 229
 - ghost system (β, γ) , 70, 191
 - ghost system (b, c) , 67, 191
 - action, 67
 - central charge, 69
 - energy-momentum tensor, 68
 - OPE, 68
 - gluing automorphism, 226
 - gluing condition, 215
 - boundary state, 215
 - crosscap state, 240, 245
 - RCFT, 225
 - solution for crosscap, 240
 - solution for free boson, 216
 - GSO projection, 136, 195, 200
- H**
 - Hamiltonian, 21, 118
 - open sector, 211
 - hexagon identity, 85
 - highest weight
 - representation, 70, 92, 174, 178
 - state, 43, 70, 92, 174
 - Hilbert space, 41
 - free boson, 55
 - free fermion, 66
 - $\mathcal{N} = 2$ super Virasoro, 178
 - $\widehat{\mathfrak{su}}(2)_1$ algebra, 96
- I**
 - Ishibashi state, 226
 - crosscap, 245
- J**
 - Jacobi triple product identity, 133
- K**
 - Kač-determinant, 71
 - Kač-Moody
 - algebra, 37, 55, 87
 - algebra, central charge, 91
 - correlation function, 99
 - current OPE, 88
 - descendant field, 100
 - primary field, 99, 102
 - Klein bottle, 230, 235
 - diagram, 236, 238
 - diagram free boson, 242
 - diagram RCFT, 246
 - fundamental domain, 236
 - modular parameter, 236
 - partition function, 232, 238
 - partition function bosonic string, 251
 - Knizhnik-Zamolodchikov equation, 99, 102
- L**
 - Laurent expansion, 22, 26, 59, 88, 114
 - loop-channel – tree-channel equivalence, 214, 223, 227, 235
- M**
 - Möbius strip, 230
 - diagram, 237, 238
 - diagram free boson, 242
 - diagram RCFT, 247
 - fundamental domain, 237

modular parameter, 237
 partition function, 234, 238
 partition function bosonic string, 253
 minimal model, *see* unitary series
 model
 Ising, 75, 105, 136
 three states Potts, 75, 109, 151
 tri-critical Ising, 75, 175
 modular group, 117–119, 173
 modular parameter
 cylinder, 211
 Klein bottle, 236
 Möbius strip, 237
 torus, 116, 117
 modular transformation
 S -transformation, 117, 224
 T -transformation, 117
 U -transformation, 117
 Dedekind η -function, 122, 138
 invariance under S , 129
 \mathcal{P} -transformation, 243
 \mathcal{P} -transformation, 245
 Θ -function, 127, 128
 ϑ -function, 138
 momentum operator, 22, 119, 218
 monodromy charge, 157, 158
 multiplet
 BPS, 183
 gravity, 202
 hyper, 202
 vector, 202

N

$\mathcal{N} = 1$
 coset construction unitary series, 106, 175
 energy-momentum tensor, 173
 extension free boson, 170
 SCFT, 169
 super OPE, 174
 super primary field, 174
 super quasi-primary, 174
 super Virasoro algebra, 172
 superfield, 173
 unitary series, 174
 $\mathcal{N} = 2$
 coset construction unitary series, 187
 extension free boson, 175
 SCFT, 175
 super chiral field, 181
 super primary field, 181, 182
 super Virasoro algebra, 177
 unitary series, 178, 184, 187
 unitary series, S -matrix, 189

 unitary series, character, 189
 unitary series, fusion rules, 190
 Neveu-Schwarz sector, 58, 59, 115, 185, 193
 Noether's theorem, 19
 normal ordered product, 38
 quasi-primary, 40
 normal ordering, 38

O

operator
 annihilation, 38
 anti-unitary, 226
 Casimir, 94
 CPT, 220, 227
 creation, 38
 fermion number, 134
 spectral flow, 187
 world-sheet parity, 231
 operator product expansion, 25
 energy-momentum tensor, 26, 174
 free fermion, 59
 general form, 34
 ghost system (b, c), 68
 Kač-Moody currents, 88
 $\mathcal{N} = 1$ super primary field, 174
 non-chiral fields, 82
 primary field, 26
 simple current, 158
 orbifold, 139
 fixed point, 141
 partition function, 142
 twisted sector, 140
 ordering
 normal ordering, 38
 radial ordering, 24, 59
 orientifold, 231
 action, 229, 241
 plane, 239–241
 projection of bosonic string, 248

P

P -matrix, 245
 parafermion, 152, 154
 partition function, 118, 119
 bosonic string, 199
 charge conjugate, 228
 cylinder, 211, 212
 free boson, 121, 122, 213
 free boson on a circle, 124
 free boson, $\mathcal{N} = 2$ extension, 179
 free fermion, 136
 Gepner model, 200
 Klein bottle, 232
 Möbius strip, 234

- simple current, 161
 - summary, 155
 - torus, 119
 - $\widehat{\mathfrak{u}}(1)_k$, 129
 - \mathbb{Z}_2 -orbifold of free boson, 141
- pentagon identity, 86
- perturbation theory
 - one-loop, 113
 - tree-level, 113
- Poisson resummation formula, 124
- propagator, 46, 68

- R**
- radial quantisation, 21
- Ramond sector, 58, 59, 115, 135, 185, 193
- reflection coefficient, 227, 247
- Rogers di-logarithm, 166

- S**
- S-matrix, 142, 229
 - for $\widehat{\mathfrak{u}}(1)_k$, 128
 - for $\widehat{\mathfrak{so}}(10)_1$, 192
 - for $\widehat{\mathfrak{so}}(2)_1$, 180
 - for $\widehat{\mathfrak{su}}(2)_k$, 147
 - for Vir_c , 150
 - $\mathcal{N} = 2$ unitary series, 189
 - parafermion, 153
 - simple current, 159
 - summary, 155
- scale factor, 6, 9, 12
- Schwarzian derivative, 27, 115
- simple current
 - boundary state, 229
 - definition, 157
 - Gepner model, 195, 197
 - $\mathcal{N} = 2$ unitary series, 190
 - OPE with primary field, 158
 - orbit, 158
 - partition function, 161
 - S-matrix, 159
- special conformal transformation, 9
- spectral flow, 184, 197
- state
 - asymptotic, 22, 23
 - boundary, 214, 215
 - crosscap, 236
 - crosscap Ishibashi, 245
 - highest weight, 70
 - Ishibashi, 226
 - norm, 35
 - null, 71, 72
- string theory
 - bosonic string, 248
 - Calabi-Yau manifold, 190, 203
 - central charges, 191, 248
 - compactification, 190, 203
 - gauge group, 253
 - heterotic string, 191, 203
 - space-time supersymmetry, 195, 197
 - tachyon, 251
 - Type I, 248, 255
 - Type IIB, 201, 211, 255
- string-function, 97, 153, 188
- Sugawara construction, 88
- superspace, 173

- T**
- T-duality, 125, 142
- T -matrix, 143
- tadpole cancellation condition, 254
- Teichmüller space, 249
- Θ -function, 126–128, 146, 179, 189
- ϑ -function, 137–138, 179
- torus, 230
 - compactification, 115
 - complex structure, 116
 - fundamental domain, 116
 - lattice, 116
 - modular group, 117
 - modular parameter, 116, 117
 - partition function, 119, 238
 - partition function bosonic string, 250

- U**
- unitary representation, 73
- unitary series
 - $\mathcal{N} = 1$ super Virasoro, 106, 174
 - $\mathcal{N} = 2$ super Virasoro, 178, 184, 187
 - Virasoro, 74, 80, 104
 - $\mathcal{W}(2, 3)$, 109

- V**
- Verlinde formula, 86, 143, 144, 228
- Verma module, 42, 70
- vertex operator, 50, 65
 - charge, 51, 53
 - conformal dimension, 53
 - current, 53
 - free boson on a circle, 125
 - states in Hilbert space, 132
 - two-point function, 53

- W**
- Ward identity, 29, 100
- world-sheet duality, *see* loop-channel – tree-channel equivalence
- world-sheet parity operator, 231